



INSTALLATION AND OPERATION INSTRUCTIONS

OWNER / INSTALLER: For your safety this manual must be carefully and thoroughly read and understood before installing, operating or servicing this heater.

INFRARED RADIANT TUBE HEATER Two Stage Pull Through System (Negative Pressure)

Models:

LTU SERIES

LTU40 - (N7/L7)

LTU50 - (N7/L7)

LTU60 - (N7/L7)

LTU75 - (N7/L7)

!INSTALLER: This manual is the property of the owner. Please present this manual to the owner when you leave the job site.

▲WARNING: Improper installation, adjustment, alteration, service, or maintenance can cause property damage, injury or death. Read the installation, operation and maintenance instructions thoroughly before installing or servicing this equipment.

IF YOU SMELL GAS:

- ! **DO NOT** try to light any appliance.
- ! **DO NOT** touch any electrical switch; **DO NOT** use any telephone in your building.
- ! **IMMEDIATELY** call your gas supplier from a neighbor's telephone. Follow the gas supplier's instructions. If you cannot reach your gas supplier, call the fire department.

FOR YOUR SAFETY

DO NOT store or use gasoline or other flammable vapors and liquids in the vicinity of this or any other appliance.

!IMPORTANT: SAVE THIS MANUAL FOR FUTURE REFERENCE.

SPACE-RAY

Post Office Box 36485 (28236) • 305 Doggett Street (28203) • Charlotte, North Carolina
Phone (704) 372-6391 • Fax (704) 332-5843 • www.spaceray.com • email: info@spaceray.com

TABLE OF CONTENTS

<u>SECTION</u>	<u>DESCRIPTION</u>	<u>PAGE</u>
1.0)	Safety	1
2.0)	Installer Responsibility	1
3.0)	General Information.....	1
4.0)	Minimum Clearances to Combustibles.....	3
5.0)	Specifications.....	4
6.0)	Packing List.....	4
6.1)	Accessory Packages	5
7.0)	Dimensions - LTU(40-75)-30 Series.....	5
8.0)	Heater Assembly Overview	6
9.0)	Typical Suspension Methods.....	7
10.0)	opening 15' body package	8
10.1)	Heater Assembly	9
11.0)	Gas Connections And Regulations	12
12.0)	Instructions For Pressure Test Gauge Connection.....	14
13.0)	Electrical Connections	15
14.0)	Venting.....	18
15.0)	Air For Combustion	22
15.1)	Direct Outside Air For Combustion	22
16.0)	Lighting and Shutdown Instructions.....	24
17.0)	Sequence of Operation.....	24
18.0)	Control Component Location.....	25
19.0)	Cleaning And Annual Maintenance	26
20.0)	Troubleshooting Guide.....	27
21.0)	Replacing Parts	31
21.1)	Removal of Spark Electrode.....	31
21.2)	Removing main burner and Gas Valve	32
21.3)	Air Switch Pressure Check.....	32
21.4)	Ignition System Checks.....	33
21.5)	Motor And Blower Wheel Check	34
22.0)	Installation Data.....	34
23.0)	Replacement Parts Guide.....	35

This heater complies with ANSI Z83.20 (current standard) and CSA 2.34. Copies of the National Fuel Gas Code (ANSI Z223.1-latest edition) are available from the CSA at 8501 East Pleasant Valley Road, Cleveland, Ohio 44131 or 55 Scarsdale Road, Don Mills, Ontario M3B 2R3. All NFPA codes are available from the National Fire Protection Association, Batterymarch Park, Quincy, Massachusetts 02269.

1.0) SAFETY

This heater is a self-contained infrared radiant tube heater. Safety information required during installation and operation of this heater is provided in this manual and the labels on the product. The installation, service and maintenance of this heater must be performed by a contractor qualified in the installation and service of gas fired heating equipment.

All personnel in contact with the heater must read and understand all safety information, instructions and labels before operation. The following symbols will be used in this manual to indicate important safety information.



Warning instructions must be followed to prevent or avoid hazards which may cause serious injury, property damage or death.



Caution instructions must be followed to prevent incorrect operation or installation of the heater which may cause minor injury or property damage.

2.0) INSTALLER RESPONSIBILITY

The installer is responsible for the following:

- The heater and venting, as well as electrical and gas supplies must be installed in accordance with these installation instructions and any applicable codes and regulations.
- Every heater shall be located with respect to building construction and other equipment so as to permit access to the heater.
- Each installer must follow the clearances to combustible materials for the heaters.
- Install the heater so that the supports and hangers are correctly spaced in accordance with these instructions. The heater must be supported by materials having a working load limit of at least 115lbs.
- Supply the owner with a copy of these Installation and Operation Instructions.
- Where unvented heaters are used, gravity or mechanical means shall be provided to supply and exhaust at least 4 CFM per 1,000 Btu/hr input of installed heaters.
- Never use the heater as a support for a ladder or other access equipment. Do not hang anything from the heater.
- Supply all installation materials necessary that are not included with the heater.
- Check the nameplate to make sure that the burner is correct for the gas type in the building and the installation altitude.

3.0) GENERAL INFORMATION

This heater is a self-contained infrared radiant tube heater for use in locations where flammable gases or vapors are not generally present (as defined by OSHA acceptable limits) and is intended for the heating of **nonresidential** spaces.

For indoor installation only. Not for use in residential dwellings.

INSTALLATION REQUIREMENTS

The installation must conform to local building codes or in the absence of local codes, with the National Fuel Gas Code ANSI Z223.1/NFPA54 or the Natural Gas and Propane Installation Code CSA B149.1. Heaters shall be installed by a licensed contractor or licensed installer. Clearances to combustibles as outlined in this manual should always be observed. In areas used for storage of combustible materials where they may be stacked below the heater, NFPA54 requires that the installer must post signs that will “specify the maximum permissible stacking height to maintain the required clearances from the heater to combustibles.”

Every heater shall be located with respect to building construction and other equipment so as to permit access to the heater. Each installer shall use quality installation practices when locating the heater and must give consideration to clearances to combustible materials, vehicles parked below, lights, overhead doors, storage areas with stacked materials, sprinkler heads, gas and electrical lines and any other possible obstructions or hazards. Consideration also must be given to service accessibility.

The heater, when installed in aircraft hangars and public garages, must be installed in accordance with ANSI/NFPA 409-latest edition (Standard for Aircraft Hangars), ANSI/NFPA 88a-latest edition (Standard for Parking Structures), and ANSI/NFPA 88b-latest edition (Standard for Repair Garages) with the following clearances:

- a. At least 10 feet above the upper surfaces of wings or engine enclosures of the highest aircraft that may be housed in the hangar and at least 8 feet above the floor in shops, offices, and other sections of hangars communicating with aircraft storage or service areas.
- b. At least 8 feet above the floor in public garages. **▲WARNING:** Minimum clearances marked on the heater must be maintained from vehicles parked below the heater.

(FOR CANADA ONLY)

- a. Installation of this appliance is to be in accordance with latest edition of CSA B149.1 (Natural Gas and Propane Installation Code).
- b. For installation in public garages or aircraft hangars, the minimum clearances from the bottom of the infrared heater to the upper surface of the highest aircraft or vehicle shall be 50 percent greater than the certified minimum clearance, but the clearance shall not be less than 8 feet.

Although these heaters may be used in many applications other than space heating (e.g., process heating), Space-Ray will not recognize the warranty for any use other than space heating.

This heater is for Indoor Installation and Covered Patio Installation only and can be used in either Vented or Unvented mode. The term Unvented actually means Indirect Vented. While the products of combustion are expelled into the building, national codes require ventilation in the building to dilute these products of combustion. This ventilation may be provided by gravity or mechanical means.

This heater is not an explosion proof heater. Where the possibility of exposure to volatile and low flash point materials exists, it could result in property damage or death. This heater must not be installed in a spray booth where the heater can operate during the spraying process. Consult your local fire marshal or insurance company.

High Altitude:

Appliances are supplied as standard for altitudes of 0 to 2,000 feet (0-610 m). High-altitude ratings are obtained by a change in the orifice size. When ordered for high altitude installations, burners are supplied by the factory ready for high altitude installation. Check the nameplate for altitude before proceeding with the installation. In Canada the adjustment for altitude is made in accordance with Standard CGA 2.17, Gas-Fired Appliances for Use at High Altitudes.

4.0) MINIMUM CLEARANCES TO COMBUSTIBLES

⚠ WARNING		
		<p>FIRE AND EXPLOSION HAZARD</p> <p>Combustible material must be located outside the clearance dimensions listed.</p> <p>Failure to do so may result in death, serious injury or property damage.</p>

Minimum clearances to combustibles shall be measured from the outer surfaces as shown in the following diagram:

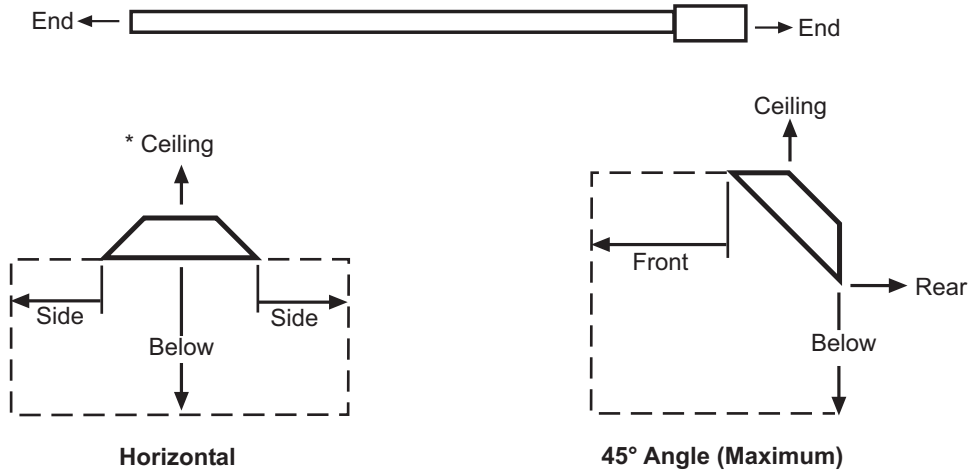

MINIMUM CLEARANCES TO COMBUSTIBLES						
Model No.	Mounted Horizontally				Angle Mounted at 45°	
	Sides	Ceiling*	Below	Ends	45° Front	45° Rear
LTU 40, 50	24"	6"	40"	30"	48"	12"
LTU 60, 75	24"	6"	60"	30"	48"	12"

* When used indirect vented, minimum clearance for CEILING must be: 12".

⚠ WARNING: Certain materials or objects, when stored under the heater, will be subjected to radiant heat and could be seriously damaged. Observe the Minimum Clearances to Combustibles listed in the manual and on the heater at all times.

NOTE:

- The clearances specified above must be maintained to combustibles and other materials that may be damaged by temperatures 90°F above ambient temperature. Clearances to combustibles are posted on the control box. In areas used for storage of combustible materials where they may be stacked below the heater, NFPA54 requires that the installer must post signs that will "specify the maximum permissible stacking height to maintain the required clearances from the heater to combustibles." Space-Ray recommends posting these signs adjacent to the heater thermostat or other suitable location that will provide enhanced visibility.
- The stated clearance to combustibles represents a surface temperature of 90 °F (32 °C) above room temperature. Building materials with a low heat tolerance (such as plastics, vinyl siding, canvas, tri-ply, etc.) may be subject to degradation at lower temperatures. It is the installer's responsibility to assure that adjacent materials are protected from degradation.

5.0) SPECIFICATIONS

Model No.	Input, Btu/hr		Heat Exchanger Length	Total Heater Length	Flue Restrictor Plate I.D. & Part #		Orifice Size				Minimum * Mounting Height	
	High	Low					Natural Gas		Propane Gas		@ Horizontal	@ 45° Angle
LTU 40	40,000	25,000	30'	16'-10"	1"	#42741040	#31	(0.120)	#49	(0.073)	10'	9'
LTU 50	50,000	31,500			1-1/8"	#42741030	3.3mm	(0.130)	#46	(0.081)	11'	10'
LTU 60	60,000	38,000			1-7/32"	#42741020	#27	(0.144)	#43	(0.089)	12'	11'
LTU 75	75,000	50,000			1-7/16"	#42741010	#20	(0.161)	#39	(0.099)	13'	12'

* MOUNT HEATERS AS HIGH AS POSSIBLE. Minimums are shown as a guideline for human comfort and uniform energy distribution for complete building heating applications. Consult your Space-Ray representative for the particulars of your installation requirements.

Type Gas	Gas Pipe Connection	Tube Diameter	Flue Connection	Fresh Air Connection	Electrical Supply	Current Rating
Natural or Propane	1/2" MPT (Male)	3"	4" Round	4" Round	120 Volt, 60Hz, 1 Phase	2.6 Amp

Fuse Rating:	Ignition System (direct spark):
Spark Module: 2 Amp 250V (for 24V Circuit)	30 second pre-purge period

6.0) PACKING LIST

A. Control/Draft Inducer Package

Part Description	QTY
Control Box Assembly	1
Draft Inducer Assembly (with 4" Starting Collar)	1
Flue Restrictor Plate (refer to 5.0) for I.D. & part number).....	1
Control Fastener Kit (#42787000)	1
Containing: 1/4 - 20 Locknuts (#02167010)	6
Gas Connector 5/8" OD x 36" (#30302360)	1
Installation & Operation Instructions (#42710010)	1

CONTROL/DRAFT INDUCER PACKAGE NUMBERS

NATURAL GAS		PROPANE GAS	
MODEL NO.	PART NO.	MODEL NO.	PART NO.
LTU40-N7	#42735510	LTU40-L7	#42735520
LTU50-N7	#42735530	LTU50-L7	#42735540
LTU60-N7	#42735550	LTU60-L7	#42735560
LTU75-N7	#42735570	LTU75-L7	#42735580

B. Body Package Descriptions

Part Description	QTY
#42734000, 15Ft. Body Package	1
Containing: #42736000, Pre-assembled 15' ALC steel tube assembly with reflectors	1
#42762010, Control End Reflector	1
#42761010, Foot End Reflector	1
#02125130, #10-24x1/2 Screws.....	6
#02189020, #10-16x1/2 Screws.....	2
#02266010, Speed Clips	14
#42769010, Sliding Clamps.....	6

6.1) ACCESSORY PACKAGES

A. Exhaust Hood Package, Part #42924000

Contains:

Exhaust Hood Assembly, #42925540.....QTY-1
 #8-18 x 1/2 Self-Drilling Screws, #02189030.....QTY-2

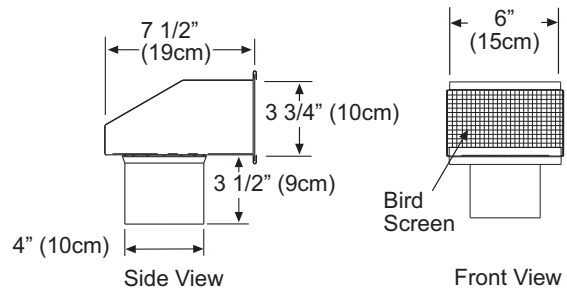

7.0) DIMENSIONS - LTU(40-75)-30 SERIES

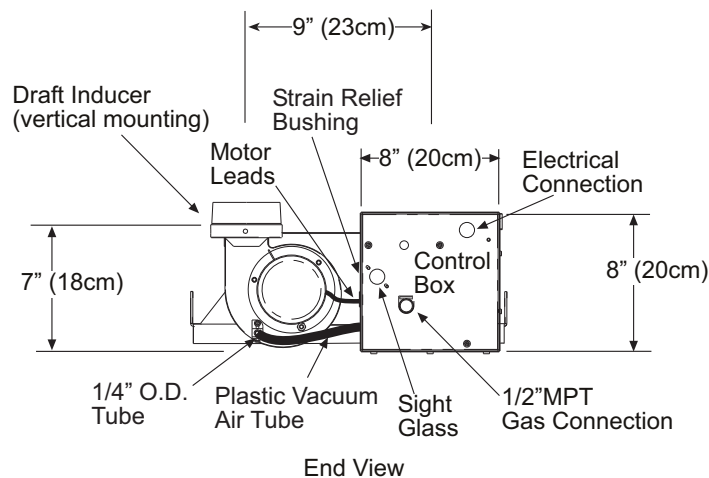
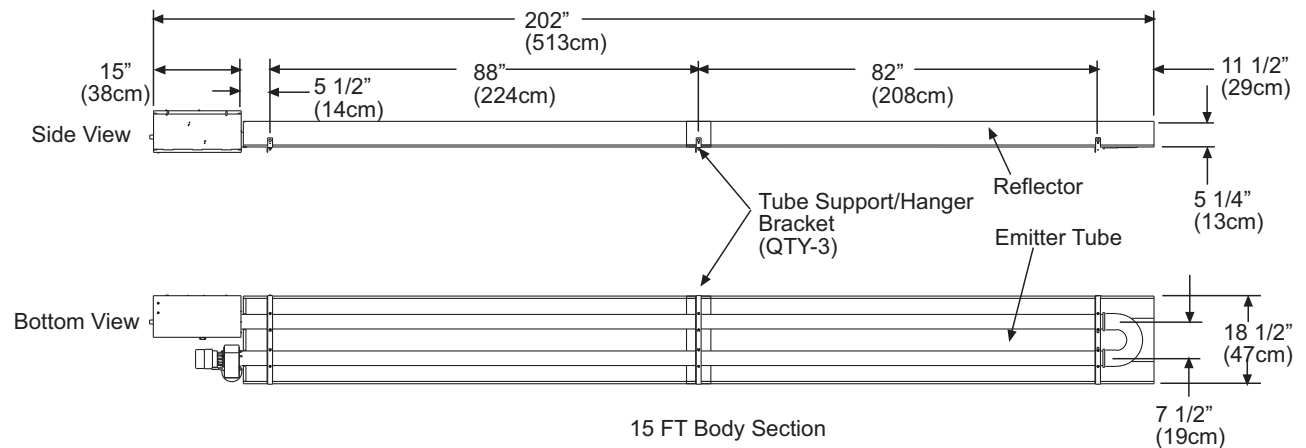

8.0) HEATER ASSEMBLY OVERVIEW

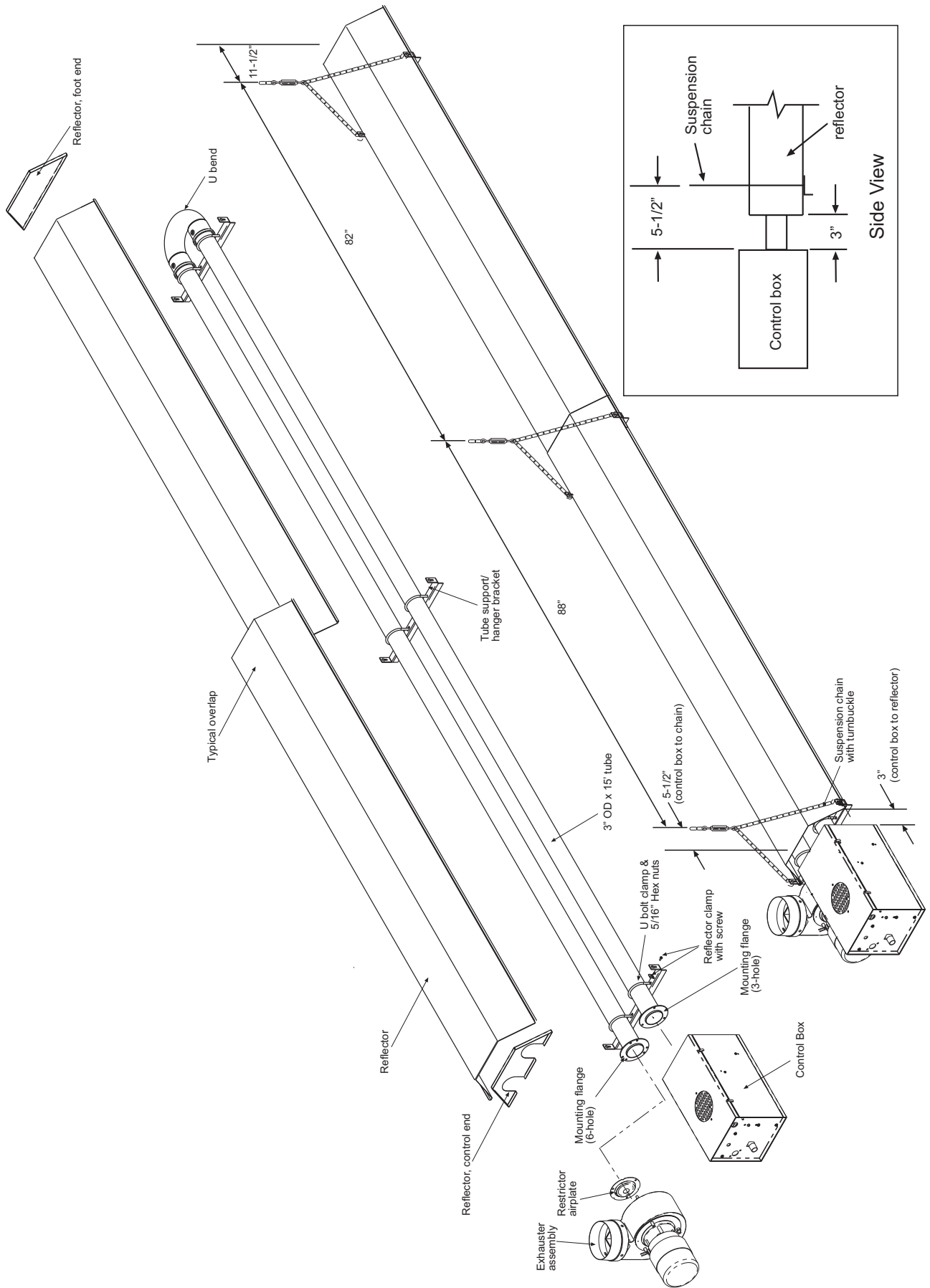

9.0) TYPICAL SUSPENSION METHODS

⚠ WARNING	
	<p>SUSPENSION HAZARD</p> <p>Burner must be secured to the mounting flange with nuts.</p> <p>All materials used to suspend the heater must have a minimum working load of 115 lbs. All "S" Hooks must be crimped closed.</p> <p>Never use the heater to support a ladder or other access equipment. Failure to do so may result in death, serious injury or property damage.</p>

Various means of suspending the heater can be used. See the following drawings for typical examples.

1. Use only noncombustible materials for suspending hangers and brackets.
2. A minimum No. 2 chain with a working load limit of 115 lbs. is required.
3. Turnbuckles can be used with chains to allow leveling of the heater. All "S" hooks and eye bolts must be manually crimped closed by the installer.
4. When using rigid means for heater suspension (rod, flat bar, etc.) provide sufficient lengths or swing joints to compensate for expansion. See Figures b and c.
5. Heaters subject to vibration must be provided with vibration isolating hangers.
6. Heaters must not be supported by gas or electric supply lines and must be suspended from a permanent structure with adequate load capacity.

Space-Ray recommends that the tube sections be suspended using chains with turnbuckles. This will allow slight adjustments after assembly and heater expansion/ contraction during operation.

If a "trapeze" method is used for tube support/hanger brackets (shown below), the minimum chain length for the two connecting chains is 36" to minimize any vibration that might be generated by the draft inducer assembly. If these chains must be less than 36", then do not use the trapeze method and, instead, use individual chains on each tube support/hanger bracket.

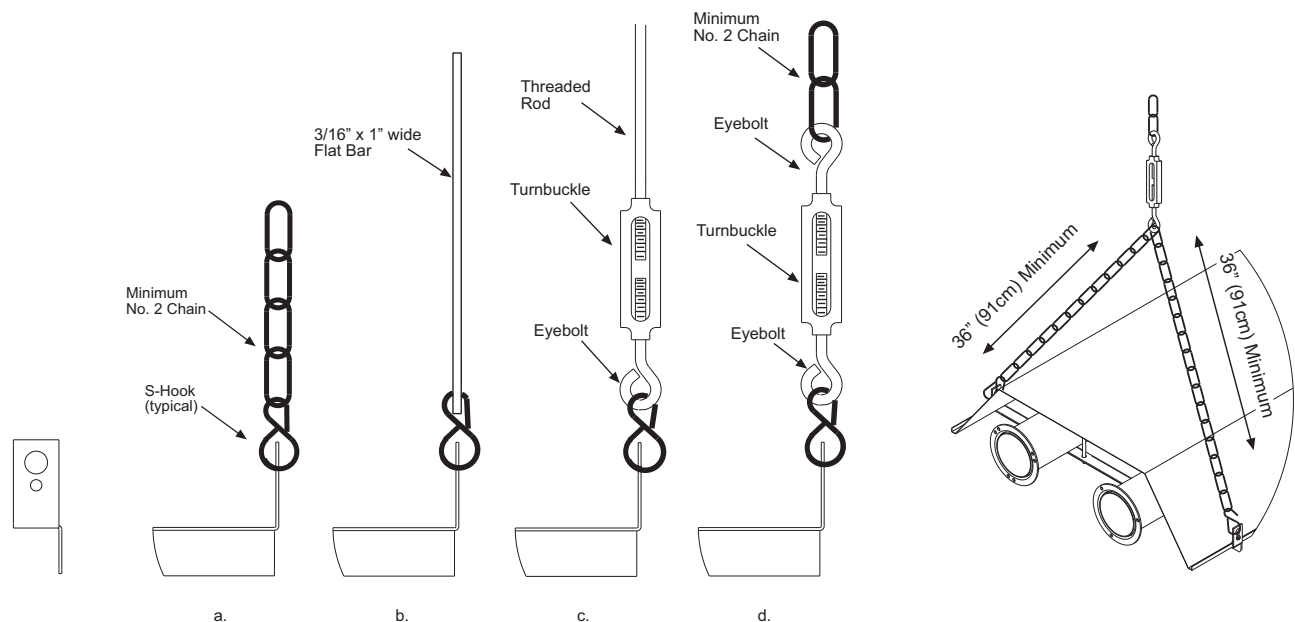

10.0) OPENING 15' BODY PACKAGE

Follow the procedure below to open the 15' body package.

1. Remove end reflectors from packaging.
2. Lift the tube at the flange end, the slide tube support/hanger bracket between marks on tubes and tighten the "U" bolt hex nuts. Follow instructions in Section 10.1 for the field assembly of the heater.

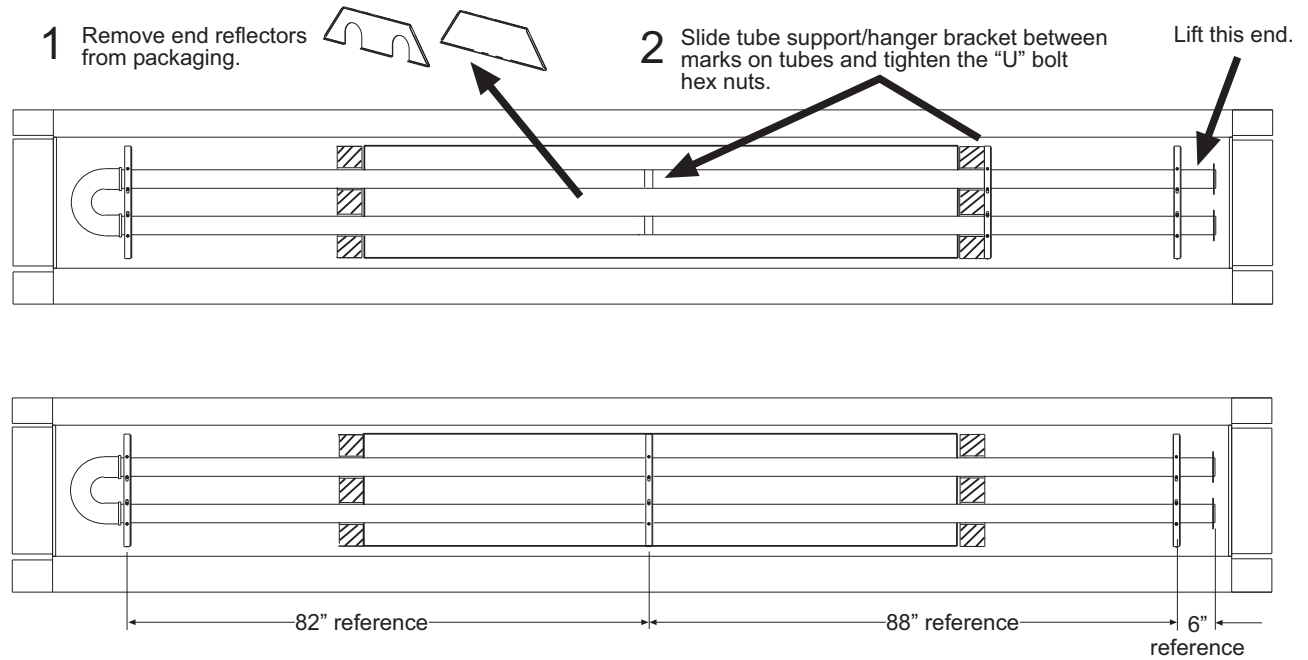

10.1 HEATER ASSEMBLY

CAUTION



CUT HAZARD

Sheet metal parts, particularly reflectors and vent have sharp edges. Always use gloves when handling.

Failure to do so may result in death, serious injury or property damage.

During field assembly of the heater, the recommended procedure is as follows:

1. Install the suspension (according to Section 7.0) using proper suspension method (see Section 9.0).

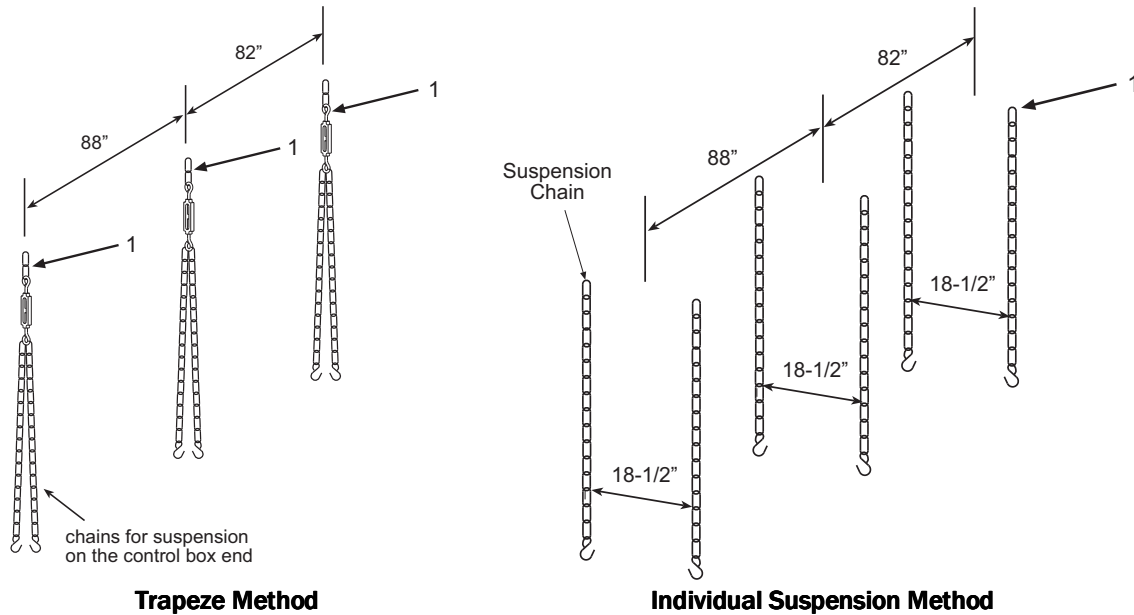

2. Lift the tube section and suspend it into place. When lifting, caution should be used to avoid damaging the assembly. Make sure that the long axis of heater is level.

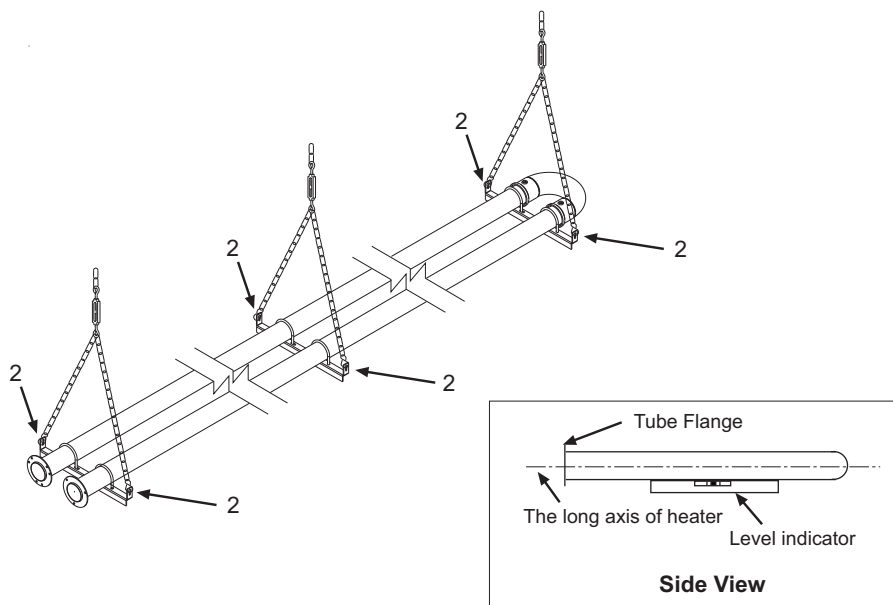

3. Assemble the reflectors onto the tube section. Leave 3" space between the tube flange and the first reflector for later mounting of control box and draft inducer.
4. Place the flanges of the control end reflector flush with the end of the first reflector. Secure by sliding speed clips onto reflector edges. Evenly space 6 speed clips on sides and top of reflectors to provide a snug fit. Place foot end reflector on the opposite end of the reflector and secure as above.

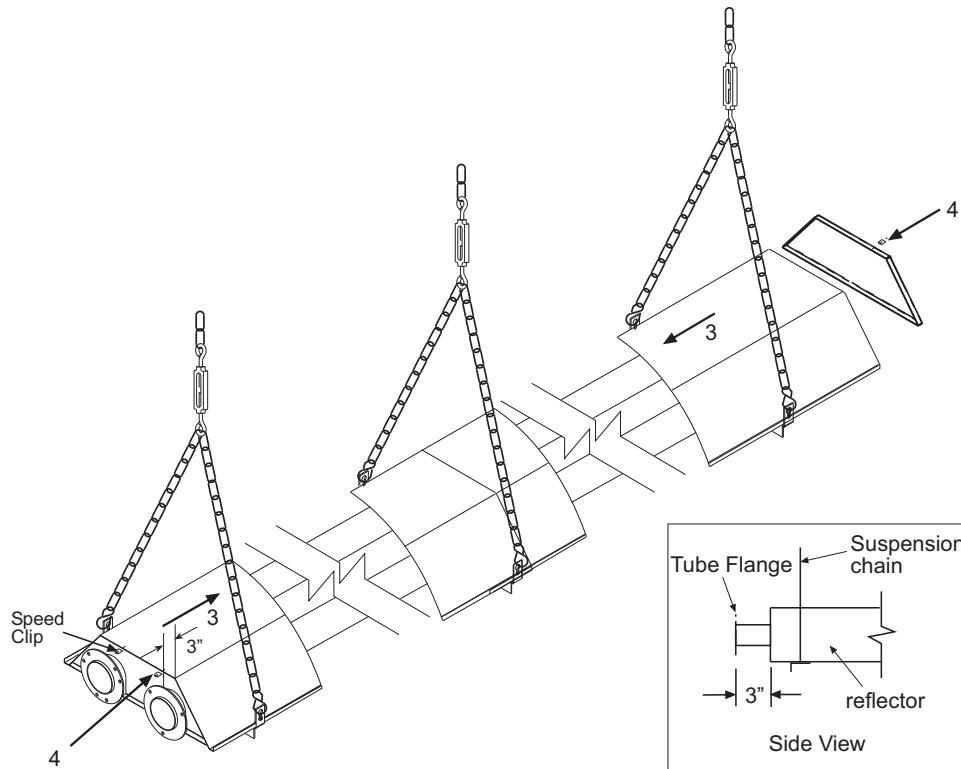

5. Attach the control box to the right-hand control tube flange and secure with 1/4-20 locknuts. The control box must be mounted with the perforated fresh air plate on top, facing the ceiling.
6. Attach the draft inducer assembly to the left-hand draft inducer tube flange and secure with 1/4-20 locknuts. A flue restrictor plate is attached to the draft inducer weld studs. Make sure this remains in place while the draft inducer is being attached to the heater body.

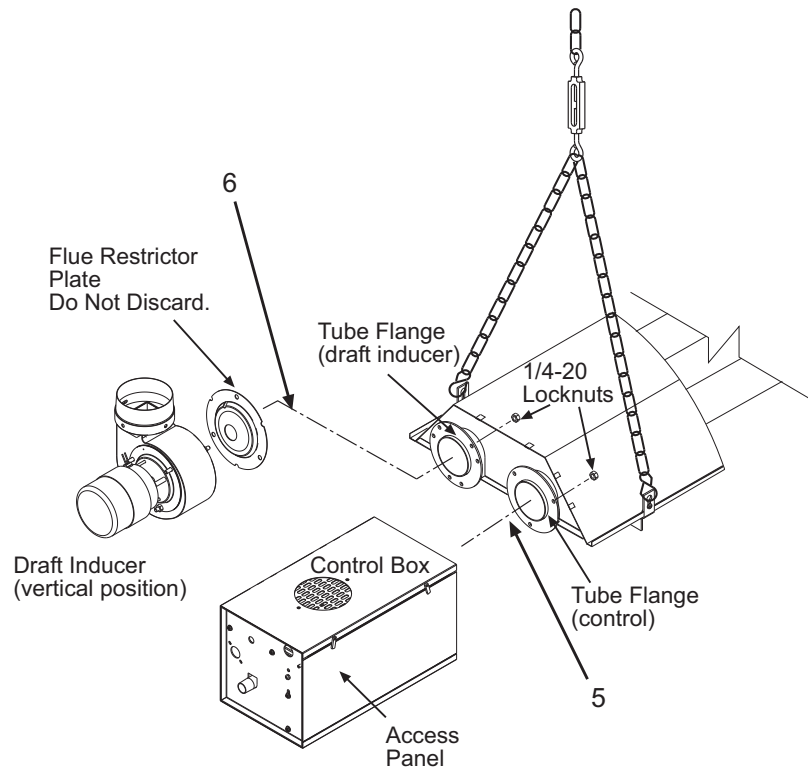

ANGLE MOUNTED HEATERS ONLY

11. The heater can be mounted horizontally or up to an angle of 45° maximum from horizontal. When the heater is to be angle mounted adjacent to a sidewall, make sure the draft inducer assembly is on the lower side of the heater so that the control box access panel is easily accessible. Make sure the long axis of heater is level. Multiple draft inducer positions can also be used as shown in the diagrams. This allows for the desired configuration of flue venting.

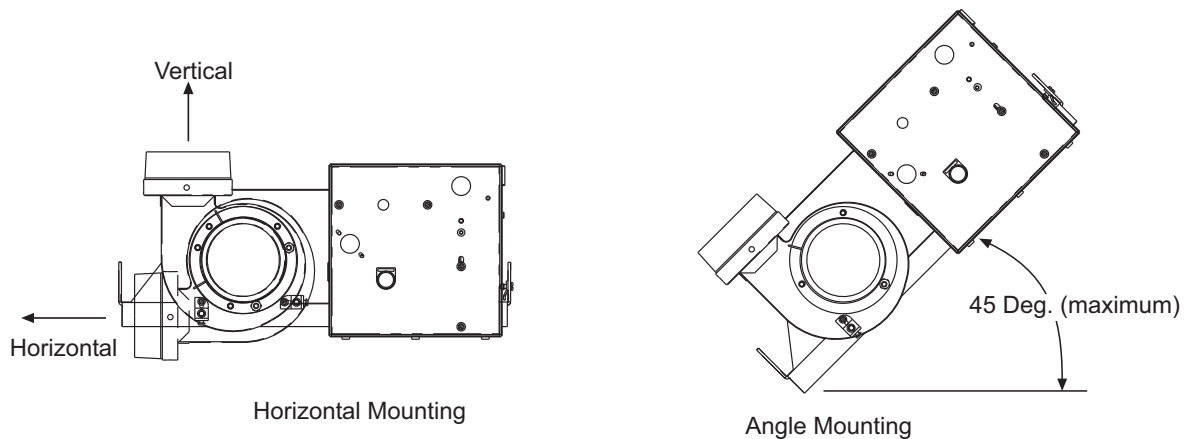

11.0) GAS CONNECTIONS AND REGULATIONS

⚠ WARNING

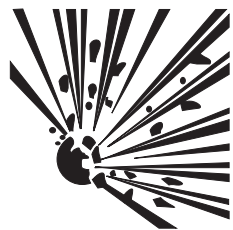

FIRE AND EXPLOSION HAZARD

Tighten flexible gas hose and components securely.

Flexible metal gas hoses must be installed without any twists or kinks in them. The hose will move during operation of the heater and it can crack if it is twisted.

Failure to do so may result in death, serious injury or property damage.

IMPORTANT BEFORE CONNECTING THE GAS TO THE HEATER

1. Connect to the supply tank or manifold in accordance with the latest edition of National Fuel Gas Code (ANSI Z223.1), and local building codes. Authorities having jurisdiction should be consulted before the installation is made. (In Canada, refer to the latest edition of CSA Standard B149.1, Natural Gas and Propane Installation Code.)
2. Check that the gas fuel on the burner rating plate matches the fuel for the application.
3. Check that the gas supply piping has the capacity for the total gas consumption of the heaters and any other equipment connected to the line.
4. Check that the calculated supply pressure with all gas appliances and heaters operating will not drop below the minimum supply pressure required for these heaters. Check inlet supply pressures on Section 12.0).
5. All gas supply lines must be located in accordance with the required clearances to combustibles from the heater as listed on the clearances label of the heater and Section 4.0) of this manual.
6. Pipe joint compounds must be resistant to the action of liquefied petroleum gases.
7. Tube heaters will expand/contract during operation. Where local codes do not prohibit, a CSA or U.L. approved flexible connector supplied with this heater is required for connections between the rigid piping and the heater. A union should be installed before the control box inlet. An approved shut off valve should be installed within 6 feet of the union.
8. The gas pipe, flexible hose and connections must be self supporting. The gas pipe work must not bear any of the weight of the heater or any other suspended assembly.
9. This appliance is equipped with a step-opening, combination gas valve. **The maximum supply pressure to the appliance is 14" W.C. or 1/2 P.S.I.** If the line pressure is more than the maximum supply pressure, then a second stage regulator which corresponds to the supply pressure must be used.

10. After all gas connections have been made, make sure the heater and all gas outlets are turned off before the **main gas supply is turned on slowly**. Turn the gas supply pressure on and check for leaks. To check for leaks, check by one of the methods listed in Appendix D of the National Fuel Gas Code.
11. If a 2nd stage regulator is used, the ball valve down stream in the supply line must be closed when purging the gas lines to prevent gas seeping through it. If initial gas pressure is higher than 14" w.c. the redundant combination gas valve is designed to lock out. Pressure build-up in the supply lines prior to the heater must be released before proper heater operation.

⚠ WARNING

DO not use an open flame of any kind to test for leaks.

KEY DIMENSIONS AND COMPONENTS OF THE GAS CONNECTIONS

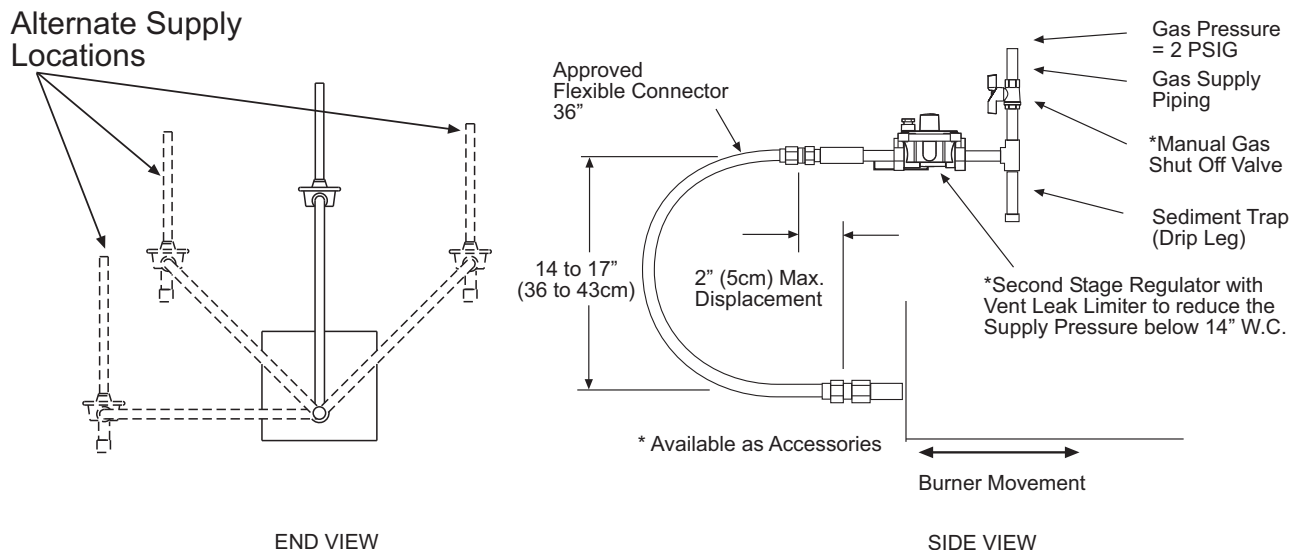

INCORRECT POSITIONS

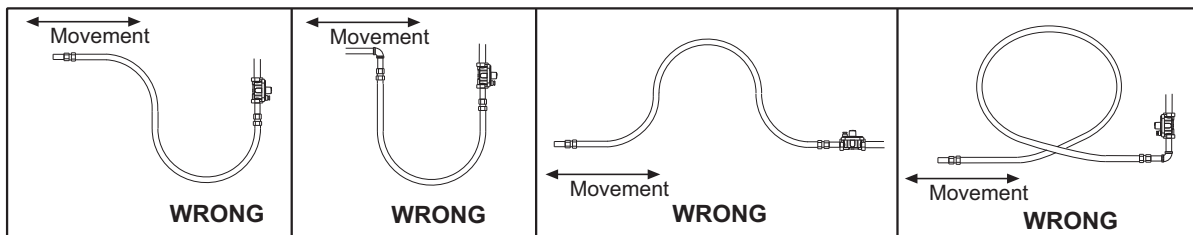

⚠ WARNING

US ONLY: Connector **MUST** be installed in “ \hookrightarrow ” configuration. Use only the 36” long connector that was furnished with this heater.

US ONLY: A gas connector certified for use on a tubular type infrared heater per the standard for Connectors for Gas Appliances, ANSI Z21.24/CSA 6.10 is supplied for installation in US only. The gas connector is 36” long and 1/2” nominal ID, and must be installed as shown above, in one plane, and without sharp bends, kinks or twists.

CANADA ONLY: A Type I hose connector should be used that is certified as being in compliance with the Standard for Elastomeric Composite Hose and Hose Couplings for Conducting Propane and Natural Gas (CAN/CGA 8.1) and is of length of 36+/- 6 in (90+/- 15 cm). The gas connector must be installed as shown above, in one plane, and without sharp bends, kinks or twists.

12.0) INSTRUCTIONS FOR PRESSURE TEST GAUGE CONNECTION

SUPPLY PRESSURE

1. The installer will provide a 1/8" N.P.T. tapped plug, accessible for test gauge connection immediately upstream of the gas supply connection to the heater.

MANIFOLD PRESSURE - COMBINATION GAS VALVE IS FACTORY SET

1. Turn the gas valve to the "OFF" position. Remove the 1/8" plug from the combination gas valve at the **Outlet Pressure Tap** below and connect a 1/8" nipple to the tapped hole. Connect the test gauge to the nipple. Turn on the gas supply.

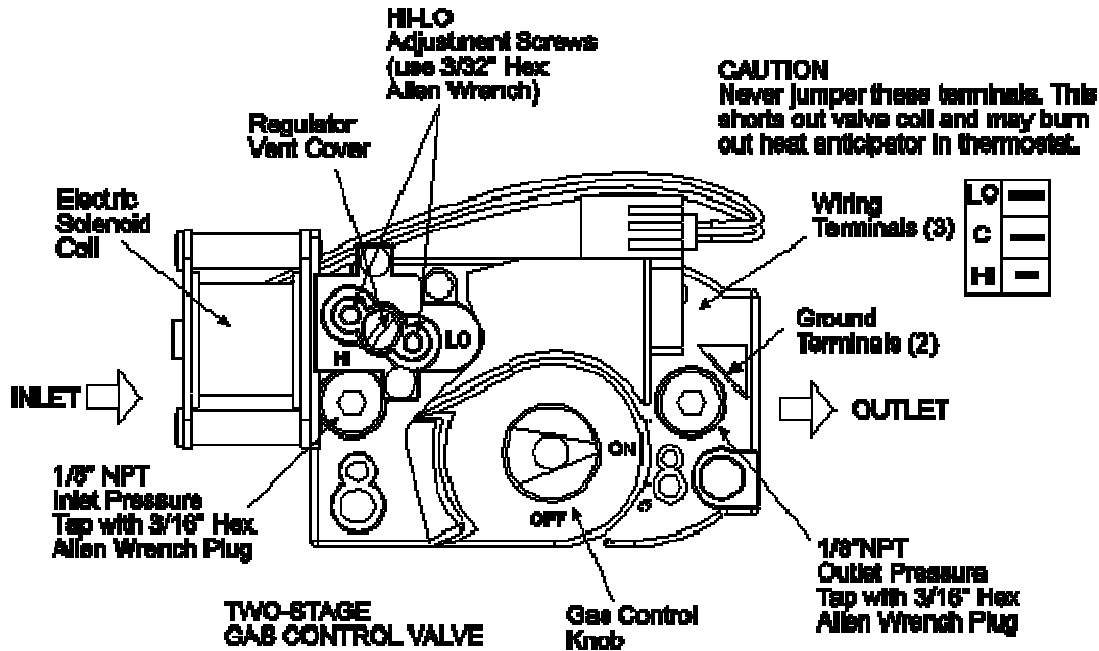

2. With the main burner operating, check the burner manifold pressure using a water column manometer. Gauges that measure pressure in pounds per square inch are not accurate enough to measure or set the manifold pressure. All measurements **MUST BE** made when this heater and all other gas burning equipment that is connected to the gas supply system are operating at maximum capacity.
3. **The combination gas valve is factory set and should not require adjustment.** If full rate adjustment is required, remove the cover screw. Using a small screwdriver, turn the adjustment screw clockwise \curvearrowright to increase or counterclockwise \curvearrowleft to decrease the gas pressure to the burner. Replace the cover screw. **NOTE: The step opening pressure of this gas valve is not adjustable.**
4. Check the burner at step pressure, observing burner ignition and flame characteristics. The burner should ignite properly and without flashback to the orifice, and should remain lit.

GAS PRESSURE TABLE				
GAS TYPE	MANIFOLD PRESSURE		SUPPLY PRESSURE	
	High	Low	Minimum*	Maximum
Natural Gas	3.5" W.C.	1.4" W.C.	5" W.C.	14" W.C.
Propane Gas	10.0" W.C.	4.0" W.C.	11" W.C.	14" W.C.

* Minimum permissible gas supply pressure for purpose of input adjustment.

13.0) ELECTRICAL CONNECTIONS

⚠ WARNING

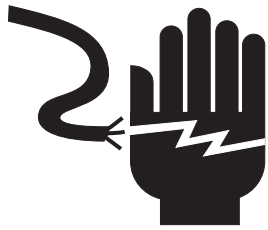

ELECTRIC SHOCK HAZARD

Disconnect electrical power and gas supply before servicing.

This appliance must be connected to a properly grounded electrical source.

Failure to do so may result in death or serious injury.

1. All electric wiring shall conform to the latest edition of the National Electrical Code (ANSI/NFPA No. 70), or the code legally authorized in the locality where the installation is made.
2. The unit must be electrically grounded in accordance with the National Electrical Code (ANSI/NFPA No. 70-latest edition). In Canada, refer to current standard C22.1 Canadian Electrical Code Part 1.
3. The wiring providing power to the heater shall be connected to a permanently live electrical circuit, one that is not controlled by a light switch.
4. The power supply to the unit should be protected with a fused disconnect switch or circuit breaker. A service switch, as required by local codes, shall be located in the vicinity of the heater (check local codes for allowable distances) and should be identified as Heater Service Switch. All electrical wiring must be located in accordance with the required Clearances to Combustibles from the heater as listed on the nameplate on the heater.
5. When connecting the **supply circuit** to the heater, wiring material having a minimum size of 14 AWG and a temperature rating of at least 90°C shall be used.

INTERNAL CONNECTION WIRING DIAGRAM — Direct Spark Ignition

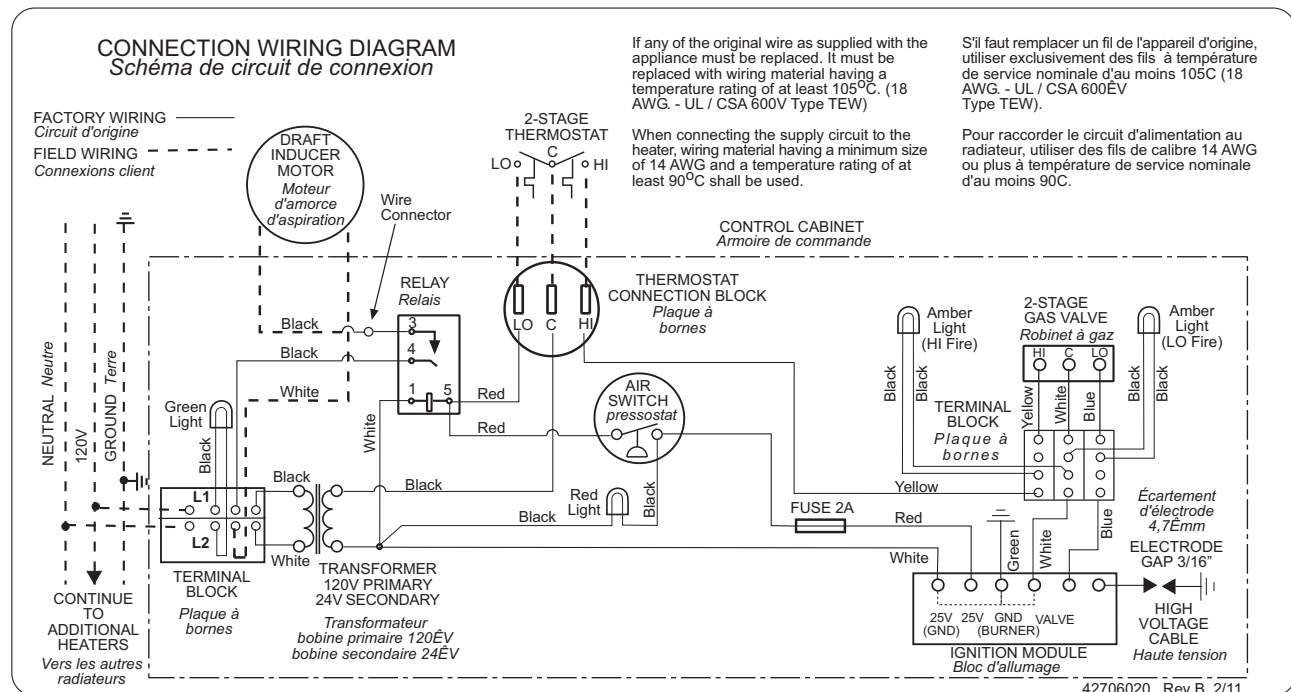

NOTES:

1. If any of the original wire as supplied with the appliance must be replaced, it must be replaced with wiring material having a temperature rating of at least 105°C. (18 Ga. CSA 600V Type TEW)
2. When connecting the supply circuit to the heater, wiring material having a minimum size of 14 AWG and a temperature rating of at least 90°C shall be used.
3. A replaceable 2-amp fuse (1-1/4" long) is fitted to the Ignition Control Module.

SCHEMATIC WIRING DIAGRAM — Direct Spark Ignition

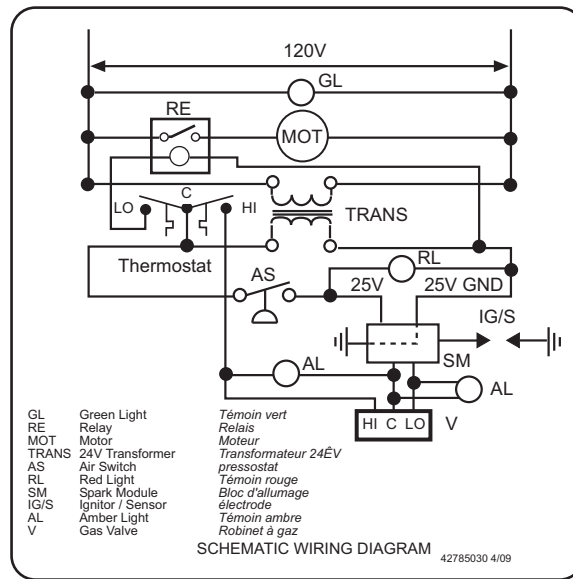

FIELD CONNECTION AND THERMOSTAT WIRING DIAGRAMS

A. LOW VOLTAGE (24V) THERMOSTAT CONNECTIONS – SINGLE HEATER PER THERMOSTAT

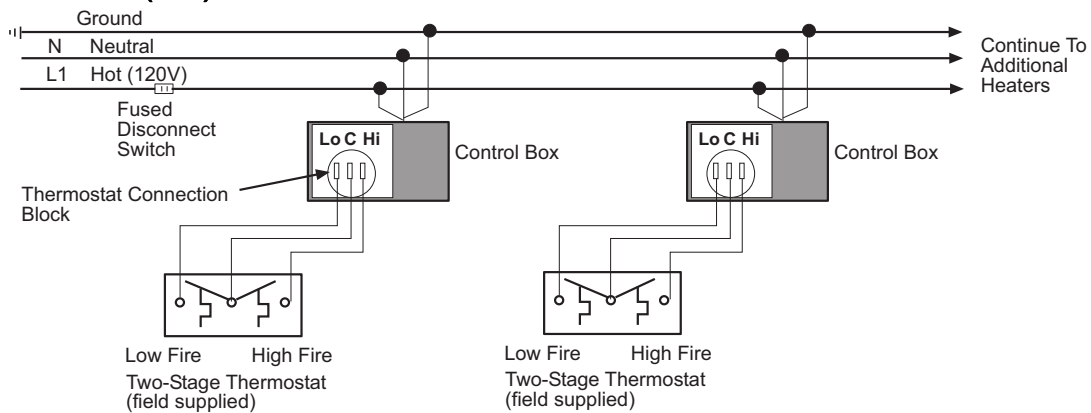

B. LOW VOLTAGE (24V) THERMOSTAT CONNECTIONS – MULTIPLE HEATERS PER THERMOSTAT

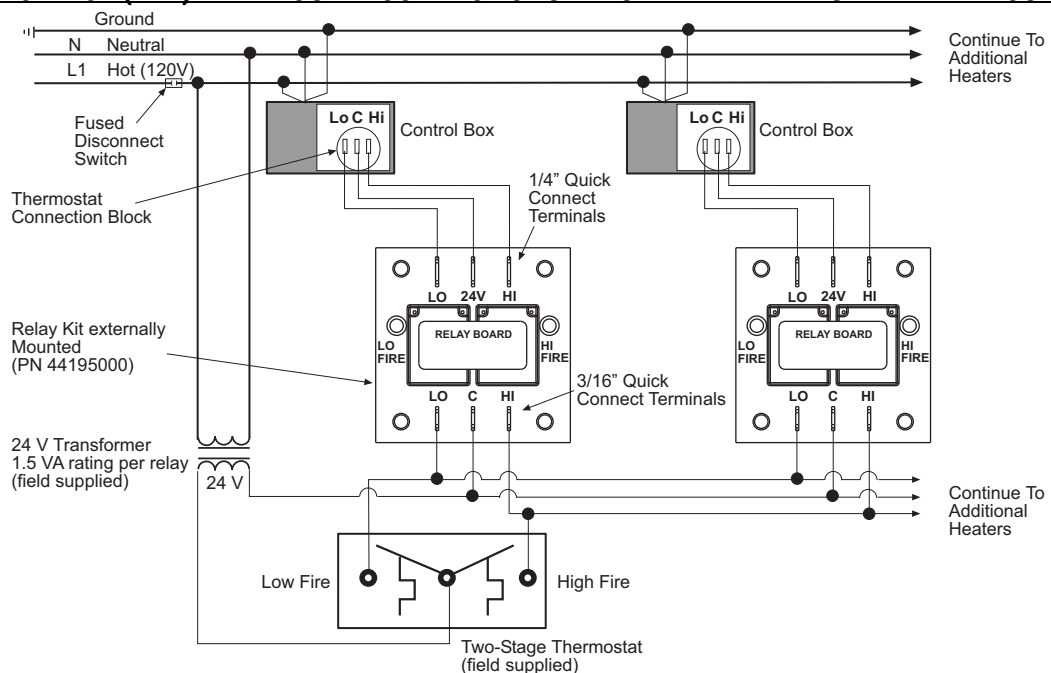

C. MANUAL SWITCH CONNECTIONS – SINGLE HEATER OPERATION PER DUAL MANUAL SWITCH

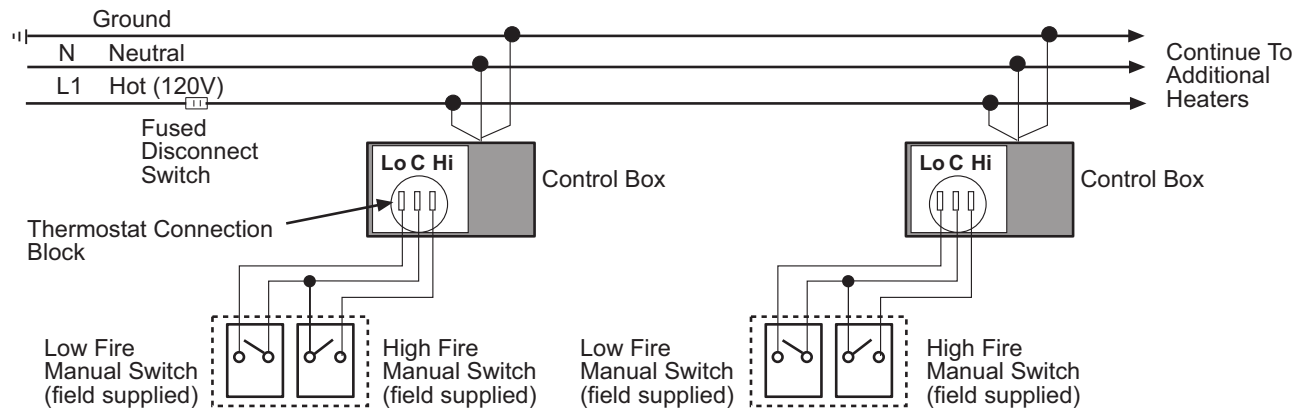

Note: Low Fire Switch MUST stay on during High Fire running.

D. MANUAL SWITCH CONNECTIONS – MULTIPLE HEATERS OPERATION PER DUAL MANUAL SWITCH

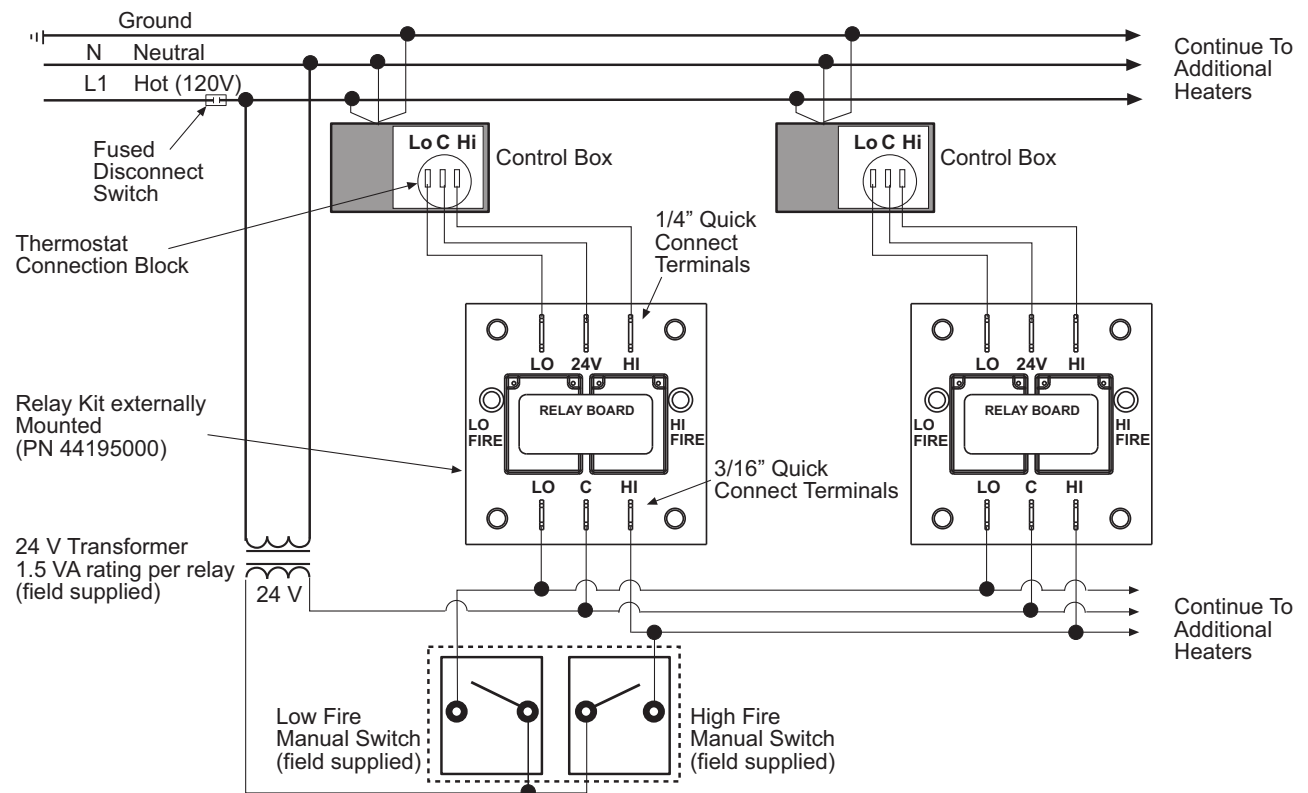

Note: Low Fire Switch MUST stay on during High Fire running.

14.0) VENTING

⚠ WARNING

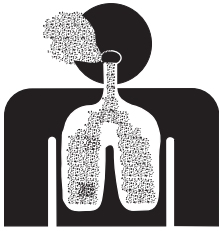

CARBON MONOXIDE HAZARD

Heaters installed in an unvented mode require a minimum ventilation flow of 4 CFM per 1,000 Btu/hr of total installed capacity.

In buildings with airborne contamination the heater must be installed with fresh air for combustion.

Failure to do so may result in death, serious injury, property damage or illness from Carbon Monoxide poisoning.

- A. **BASIC FLUE VENTING** — Venting must comply with the latest edition of the National Fuel Gas Code (ANSI Z223.1-latest edition) or the authority having jurisdiction. Other venting references are in the equipment volume of the ASHRAE Handbook.

Model	Heat exchanger length ft	Maximum vent length ft. (4" diameter)		Maximum Fresh air intake length ft (4" diameter)
		Vertical Venting	Sidewall Venting	
LTU 40	30	100	75	50
LTU 50	30	100	75	50
LTU 60	30	100	75	50
LTU 75	30	100	75	50

SINGLE HEATER VENTING (VERTICAL THROUGH THE ROOF)

- When venting the heater to outside of building through a roof, use single-wall metal pipe. This is to be constructed of galvanized sheet metal or other approved noncombustible corrosion-resistant material as allowed by state or local codes.
- A vent passing through a combustible roof shall extend through an approved clearance roof thimble. Double-wall, Type B vent must be used for the portion of the vent system which passes through the combustible roof. An approved vent cap must be attached to end of the flue.
- The maximum equivalent length of vent pipe should be carefully observed. A safety switch in the heater is designed to shut the heater off before excessive flue restriction causes bad combustion. Refer to the Vent Sizing Table for maximum vent lengths and vent pipe diameter.
 - Minimum Equivalent Length = 5 ft. of pipe
 - Maximum Equivalent Length = 75 ft. of pipe
 Use the following correction factors to obtain the equivalent length:
 - Subtract 15 ft. if the run is horizontal.
 - Subtract 10 ft. for an approved vent cap.
 - Subtract 10 ft. for each elbow beyond 15 ft. from the heater.
 - Subtract 15 ft. for each elbow within 15 ft. of the heater.
- Joints between sections of piping shall be fastened by sheet metal screws or other approved means and should be sealed to prevent leakage of flue gas into building. Aluminum or Teflon tape suitable for 550°F (3M Company tapes 433 or 363) or silicone sealant is recommended.
- Avoid locating elbows in the first 5' of vent pipe whenever possible. Limit to (2) 90° elbows. When vent pipe is in a horizontal run, it must have 1/4 inch per foot rise.
- All portions of the vent pipe shall be supported to prevent from sagging (6' spacing is recommended).
- When the vent pipe passes through areas where the ambient temperature is likely to induce condensation of the flue gases, the vent pipe should be insulated and a condensation drain should be provided.
- Minimum clearance for single-wall flue pipe to combustible material shall be 6 inches. This may be reduced when the combustible material is protected as specified in the National Fuel Gas Code or the authority having jurisdiction.
- Single-wall metal pipe shall not originate in any unoccupied attic or concealed space and shall not pass through any attic, inside wall or concealed space, or through any floor. For the installation of a single-wall metal pipe through an exterior combustible wall, refer to latest edition of the National Fuel Gas Code or the authority having jurisdiction.
- A venting system shall terminate at least 3 ft. above any forced air inlet located within 10 ft.

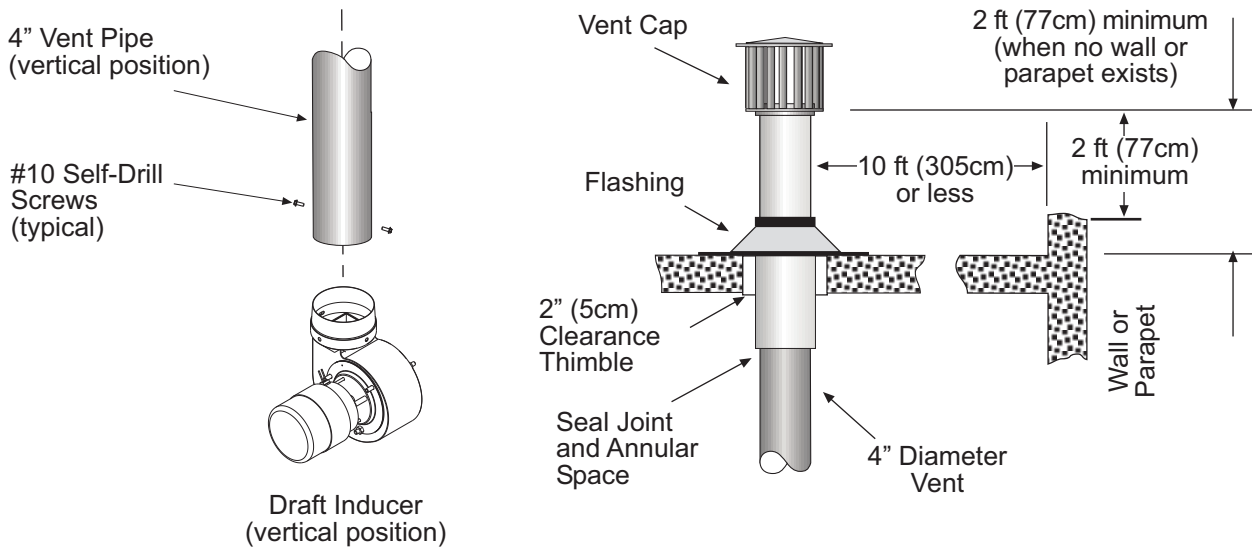

SINGLE HEATER VENTING (HORIZONTAL THROUGH SIDEWALL)

When venting the heater horizontally through a combustible outside sidewall, the same requirements listed previously for venting **Vertical Through The Roof** apply except as follows:

1. A vent passing through a combustible wall must pass through an approved clearance thimble (Air-Jet #4VT or Ameri-Vent #4EWT or other thimbles) that are listed by a nationally recognized testing agency. Double-wall Type B vent must be used for the portion of the vent system which passes through the combustible sidewall.
2. An approved vent cap (Bredert or equal) must be attached to the end of the vent pipe.
 - Minimum Equivalent Length = 5 ft. of pipe
 - Maximum Equivalent Length = 75 ft. of pipe

NOTE: To minimize problems associated with condensation in long horizontal runs, vent pipe can be insulated.

3. When venting through a sidewall, the horizontal vent pipe shall rise not less than 1/4 inch per foot from the start of the vent system to the vent terminal. All portions of the vent pipe shall be supported to prevent sagging. (6' spacing is recommended)
4. A minimum clearance of 6 inches must be maintained between the outside wall and vent cap (1/8" clearance will provide stability under high wind conditions).
5. The horizontal venting system shall not terminate:
 - Less than 4 ft. (1.2m) below, 4 ft. (1.2m) horizontally from or 1 ft. (30cm) above any door, operable window or gravity air inlet into any building. The bottom of the vent terminal shall be located at least 7 ft. (2.1m) above grade or above snow accumulation level as determined by local codes.
 - Less than 3 ft. (0.9m) from a combustion air inlet.
 - Less than 3 ft. (0.9m) from any other building opening or any gas service regulator.
 - Less than 7 ft. (2.1m) above public walkways.
 - Directly over areas where condensate or vapor could create a nuisance or hazard or be harmful to the operation of gas utility meters, regulators, relief valves, or other equipment. Building materials should be protected from flue gases and condensate.
 - Less than 12" (0.30m) when directly below a combustible overhang.
6. In regions of the country where prevailing winds are consistently higher than 40 mph, it may be necessary to terminate the vent system above the roof level.

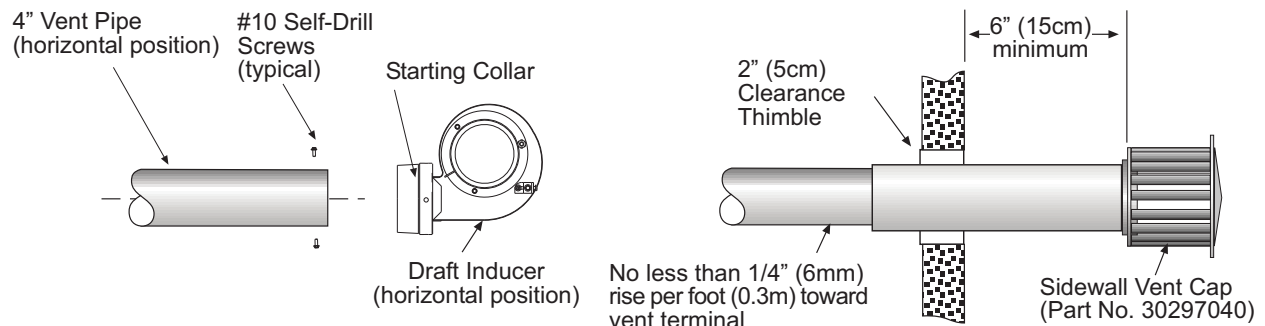

MULTIPLE HEATER VENTING (CONNECTIONS INTO A COMMON VENT OR MANIFOLD)

Requirements for venting of multiple heaters are the same as described for **SINGLE HEATER VENTING** except as follows:

1. The common vent size and total vent height is normally determined by the number of heaters per common vent, length of horizontal connector runs, and connector rise. Connector lengths should be as short as possible and have a minimum 1/4 inch per foot rise. Without regard to connector rise and total vent height due to many possible venting configurations, the following should be observed:
 - Common vent pipe & vent connector diameter should be no less than that shown in the following Vent Sizing Table.
 - The connector length should be no more than 75% of the vertical portion of vent above the connector.
 - Where possible, use a Y-connector to the common vent.
2. Material for connectors should be constructed of galvanized sheet metal or other approved noncombustible corrosion resistant material as allowed by state or local codes. All common vent pipe should be insulated flue pipe or double-wall, Type B vent.
3. Avoid unnecessary bends. Limit to two (2) 90° elbows.
4. The entire length of vent connector shall be readily accessible for inspection, cleaning and replacement.
5. Groups of heaters with a common vent must be controlled by a common thermostat.

! WARNING

If any heater connected to a common vent system for multiple heaters is found inoperative, the heater should be disconnected from the vent system and its entrance into the vent system capped.

Multiple Heater Vertical Venting Arrangement

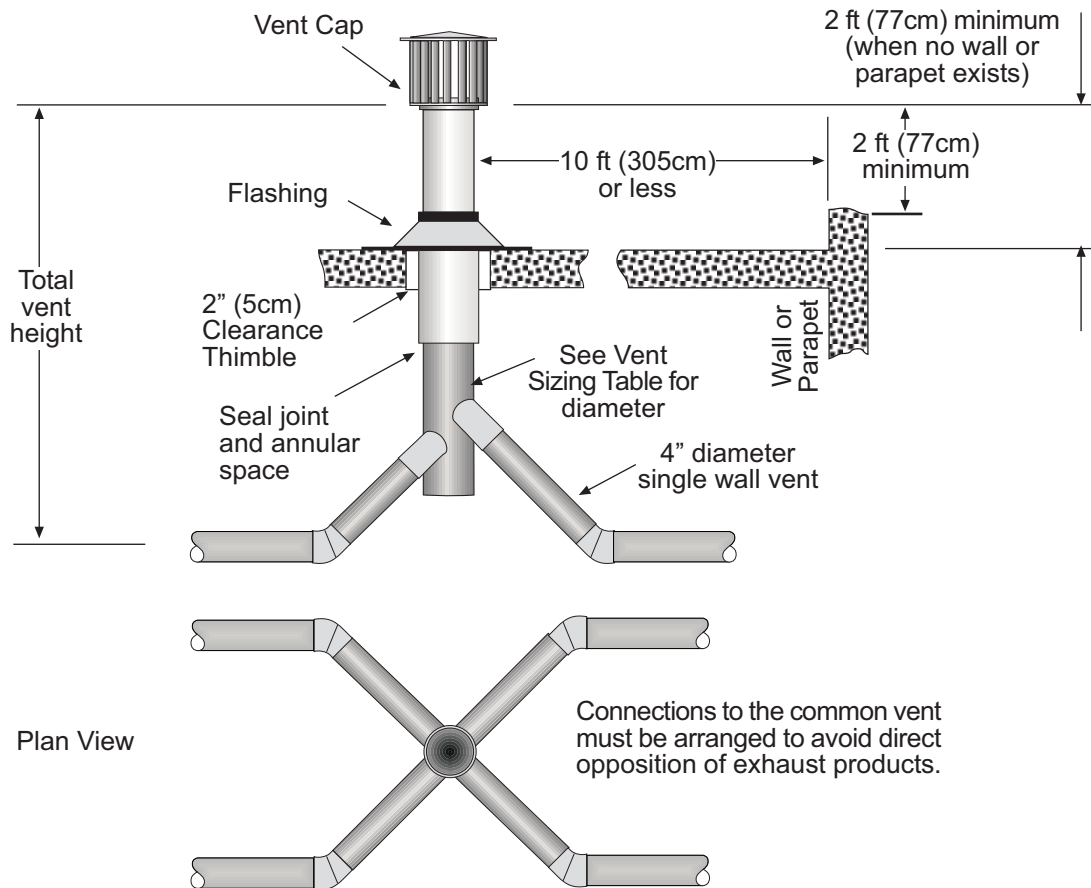

Multiple Heater Horizontal Venting Arrangement

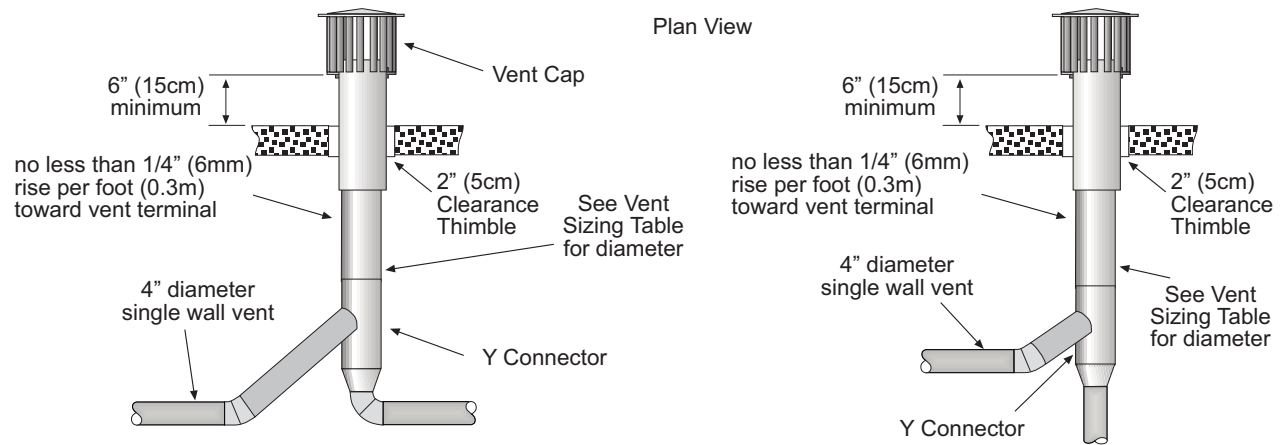

Multiple Heater Venting (Connections into a Manifold)

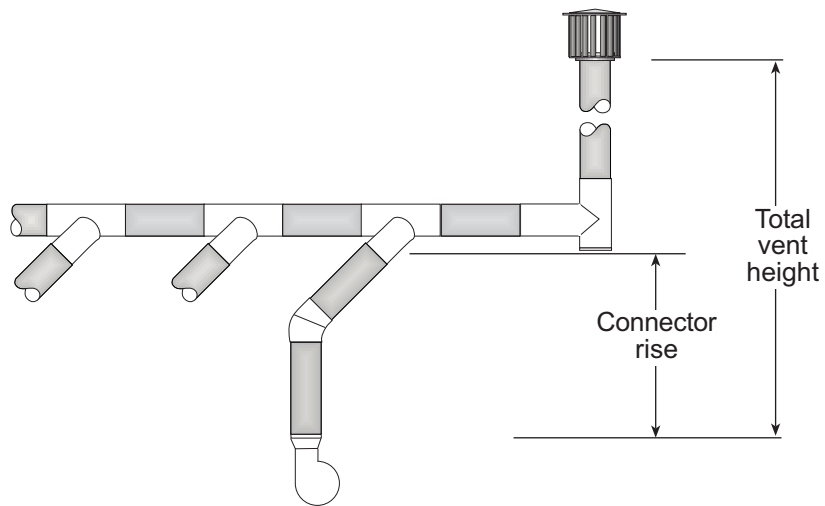

VENT SIZING TABLE — Multiple Heater Venting					
	Number of Heaters				
	1	2	3	4	5
LTU 40	4"	4"	5"	5"	6"
LTU 50	4"	4"	5"	5"	6"
LTU 60	4"	5"	6"	6"	7"
LTU 75	4"	5"	6"	6"	7"

COMMON VENT DIAMETER
(If a size is not available use the next larger size.)

THE ABOVE ILLUSTRATIONS AND TABLE OF VENT SIZES FOR COMMON VENTING OF MULTIPLE HEATERS ARE IN ACCORDANCE WITH THE NATIONAL FUEL GAS CODE ANSI Z223.1-LATEST EDITION, NFPA 54-LATEST EDITION, EQUIPMENT VOLUME OF 1988 ASHRAE HANDBOOK, CURRENT CAN/CGA-B149.1/2-M86 INSTALLATION CODE, AND AGA PUBLICATION NO. 10M5.85 2.5-2 ON FUNDAMENTALS OF GAS APPLIANCE VENTING AND VENTILATION-REVISED BUT ARE NOT A PART OF THE CSA CERTIFICATION.

- B. INDIRECT VENTING (UNVENTED HEATERS)** — This heater requires ventilation in the building to dilute the products of combustion and provide fresh air for efficient combustion. Where unvented heaters are used, gravity or mechanical means shall be provided to supply and exhaust at least 4 CFM per 1,000 Btu/hr input of installed heaters. Exhaust vents must be located at the highest point above and in the vicinity of the heaters, and the inlet vents must be located below the level of the heaters. An exhaust hood (Part #42924000) must be placed on the outlet collar of the draft inducer or on the existing 4" starting collar when used unvented and **must be mounted only in an upright position and directed towards the reflector body as shown.**

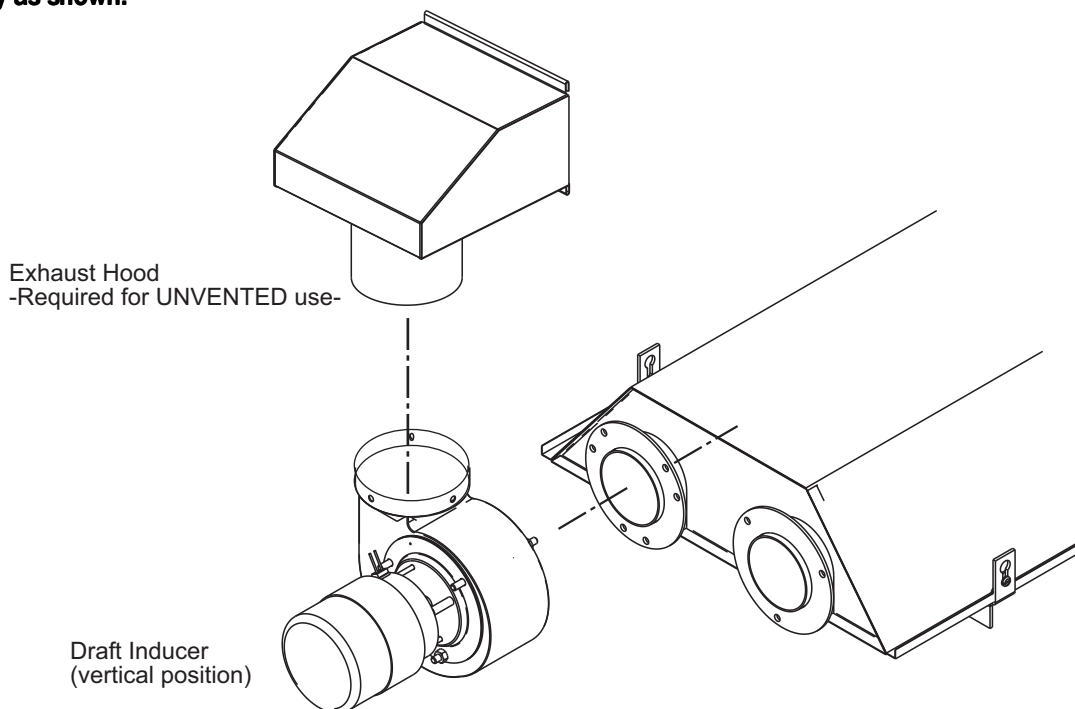

15.0) AIR FOR COMBUSTION

If indoor combustion air is to be supplied for a tightly enclosed area, one square inch of free area opening shall be provided below the heater for each 1,000 Btu/hr of heater input. When outside air is used, the opening below the heater shall be one square inch of free area for each 4,000 Btu/hr of heater input. In contaminated atmospheres or high humidity areas, optional outside air for combustion is recommended. Adequate clearances around the air inlet screen must be maintained at all times. In larger open areas of buildings, infiltration normally is adequate to provide air for combustion.

15.1) DIRECT OUTSIDE AIR FOR COMBUSTION

Outside combustion air should be supplied directly to the heater when the building is subject to negative pressure, or when contaminants or high humidity are present in the building air. These contaminants include paints, solvents, corrosive vapors or any other foreign particles that may cause damage to the heater or result in poor combustion.

Outside combustion air can be brought directly to the heater by a 4" diameter duct less than 50 ft. long or equivalent (see table in Section C based on selected model and heat exchanger lengths). This is attached to the 4" diameter starting collar. The starting collar is fitted to the top of the control box cabinet **after first removing and discarding the perforated cover.** An approved vent cap must be placed directly on the end of the outside combustion air inlet pipe. The combustion air inlet should be not less than 3 ft. (0.9m), either vertically or horizontally, from the flue vent termination. The air intake terminal must be located not less than 1 ft. (30cm) above grade. It is good installation practice to supply combustion air from the same pressure zone as the vent outlet. Avoid bringing combustion air to the heater from an attic space. There is no guarantee that adequate combustion air will be supplied.

In colder climates, where necessary, insulate the outside combustion air duct. Avoid locating the outside combustion air duct directly above the control box. Provide a capped cleanout T as necessary. In high humidity applications, the control box should be sealed with silicone sealer.

In **multiple heater applications**, the combustion air intake may be ducted individually or common ducted in the same configuration as shown for venting in Section C. For combustion air intake duct sizing, please refer to the **Vent Sizing Table** and use the diameter indicated, based on the number of heaters per duct.

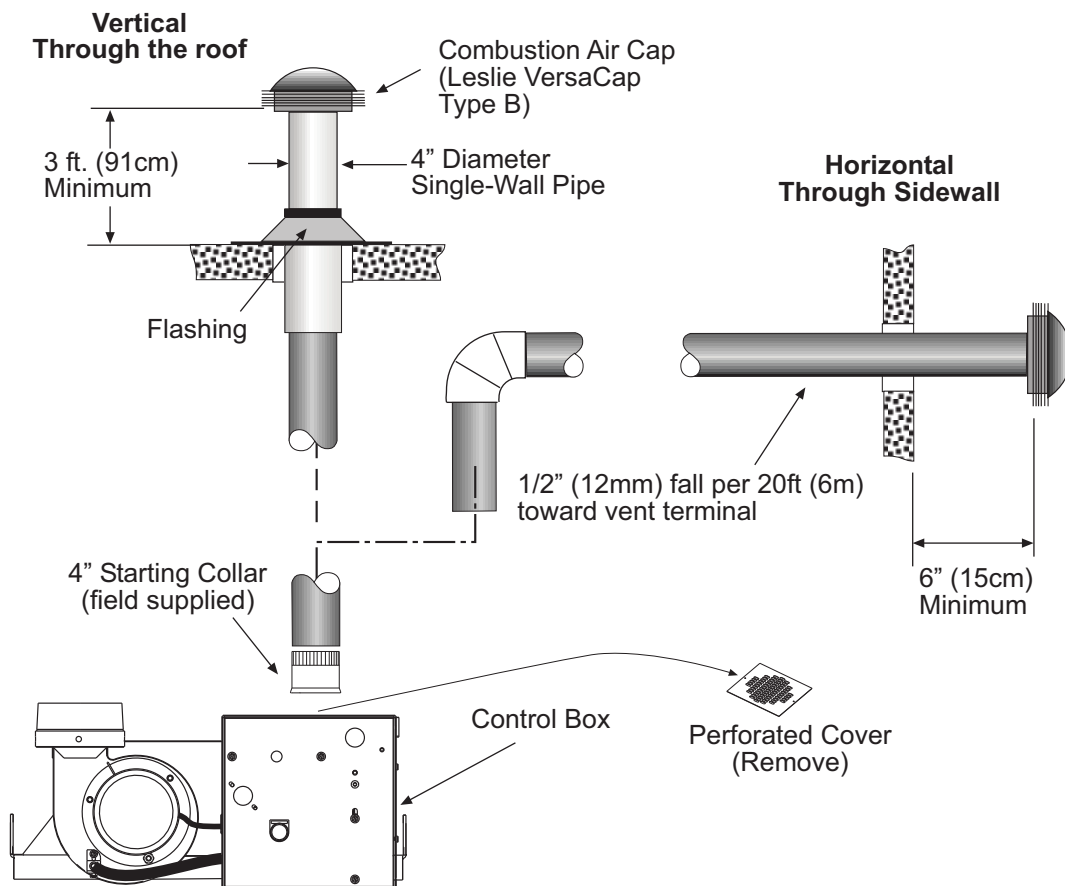
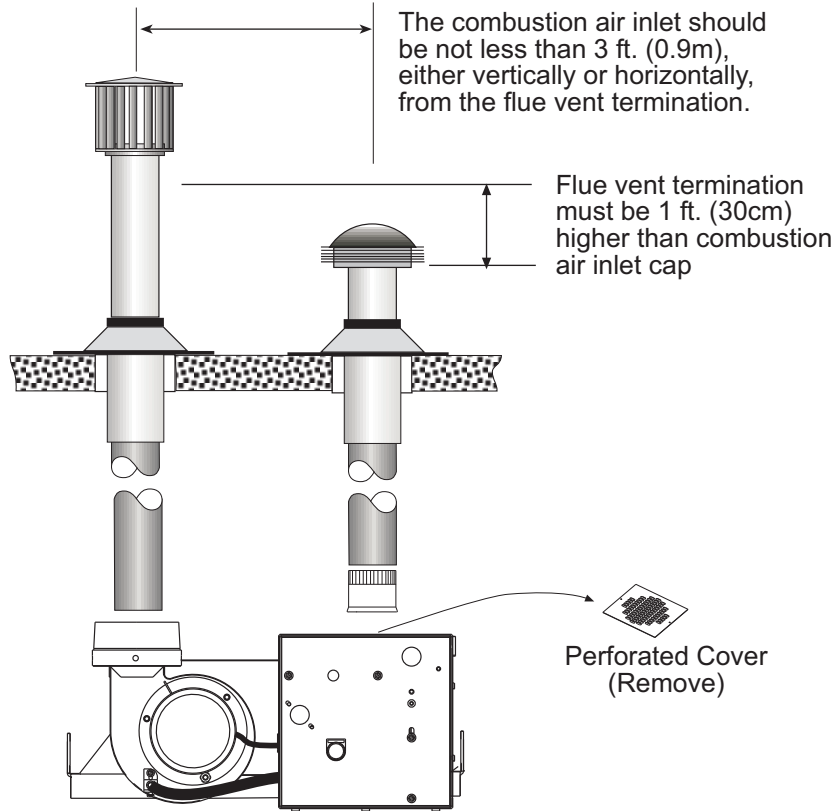

16.0) LIGHTING AND SHUTDOWN INSTRUCTIONS

⚠ WARNING

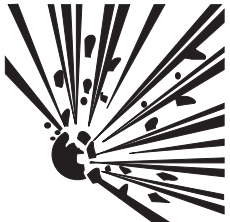



FIRE AND EXPLOSION HAZARD

Never operate the heater with the access panel open or removed.

The access panel must be closed tightly during operation.

Failure to do so may result in death, serious injury or property damage.

1. Turn on the gas and electrical supply. Rotate the gas valve knob counter-clockwise ⤴ to the “ON” position.
2. Set the thermostat to call for heat. The blower motor will energize.
3. Ignition should occur after the 30-second air pre-purge.
4. If ignition fails, the unit will spark for approximately 21 seconds and go into safety lockout. Turn the thermostat (power) off for 60 seconds to take the system out of lockout.
5. If the heater does not light, manually reset the thermostat or shut off power completely for 5 minutes before attempting to relight.
6. To permanently shut down the heater, rotate the gas valve knob clockwise ⤵ to the “OFF” position and turn off the gas and electrical supply.

NOTE: The lighting and shutdown instructions are also shown on the permanent nameplate label attached to the heater control box.

17.0) SEQUENCE OF OPERATION

The chart below shows the sequence of operation for the normal operating cycle.

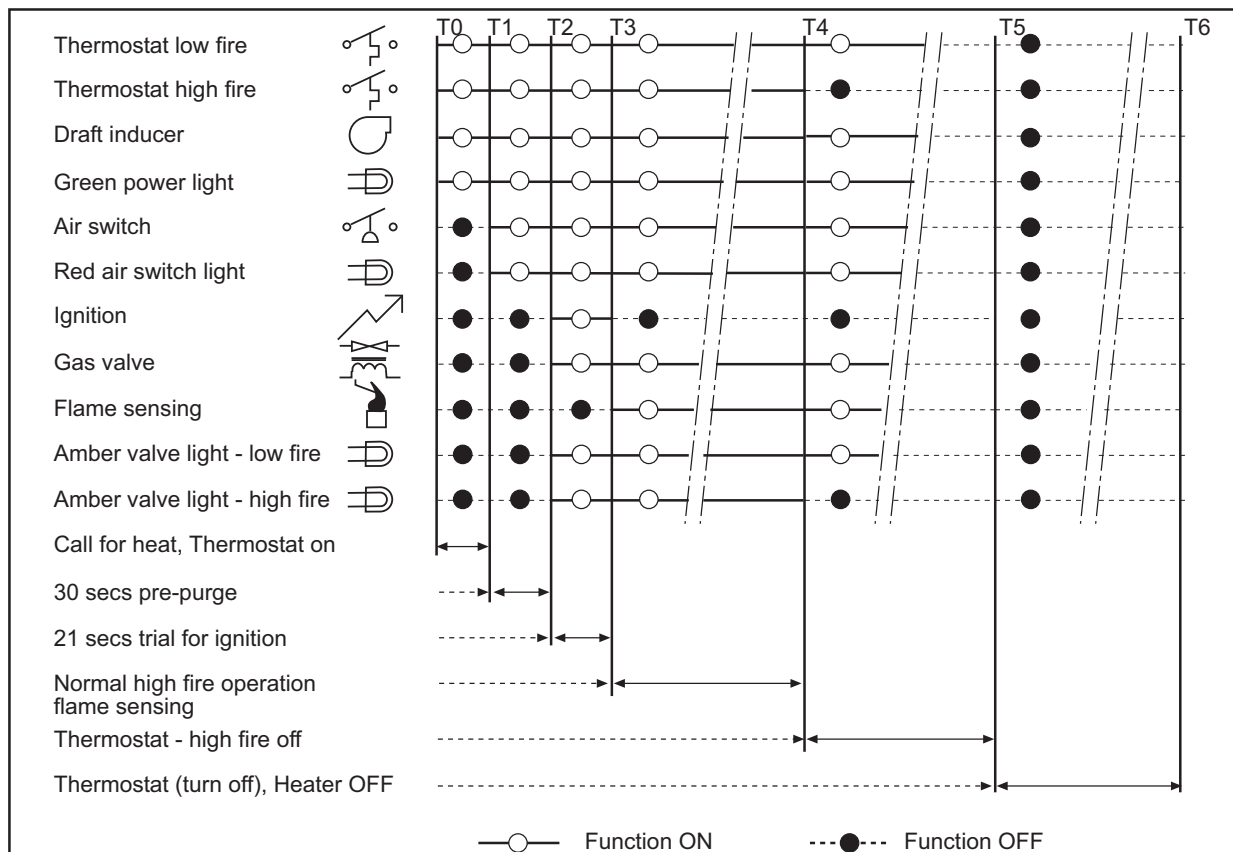

If the flame is not sensed during sequence T3 or T4, then the burner will automatically begin ignition as in sequence T2. If the flame is not re-established the heater will go to lockout.

18.0) CONTROL COMPONENT LOCATION

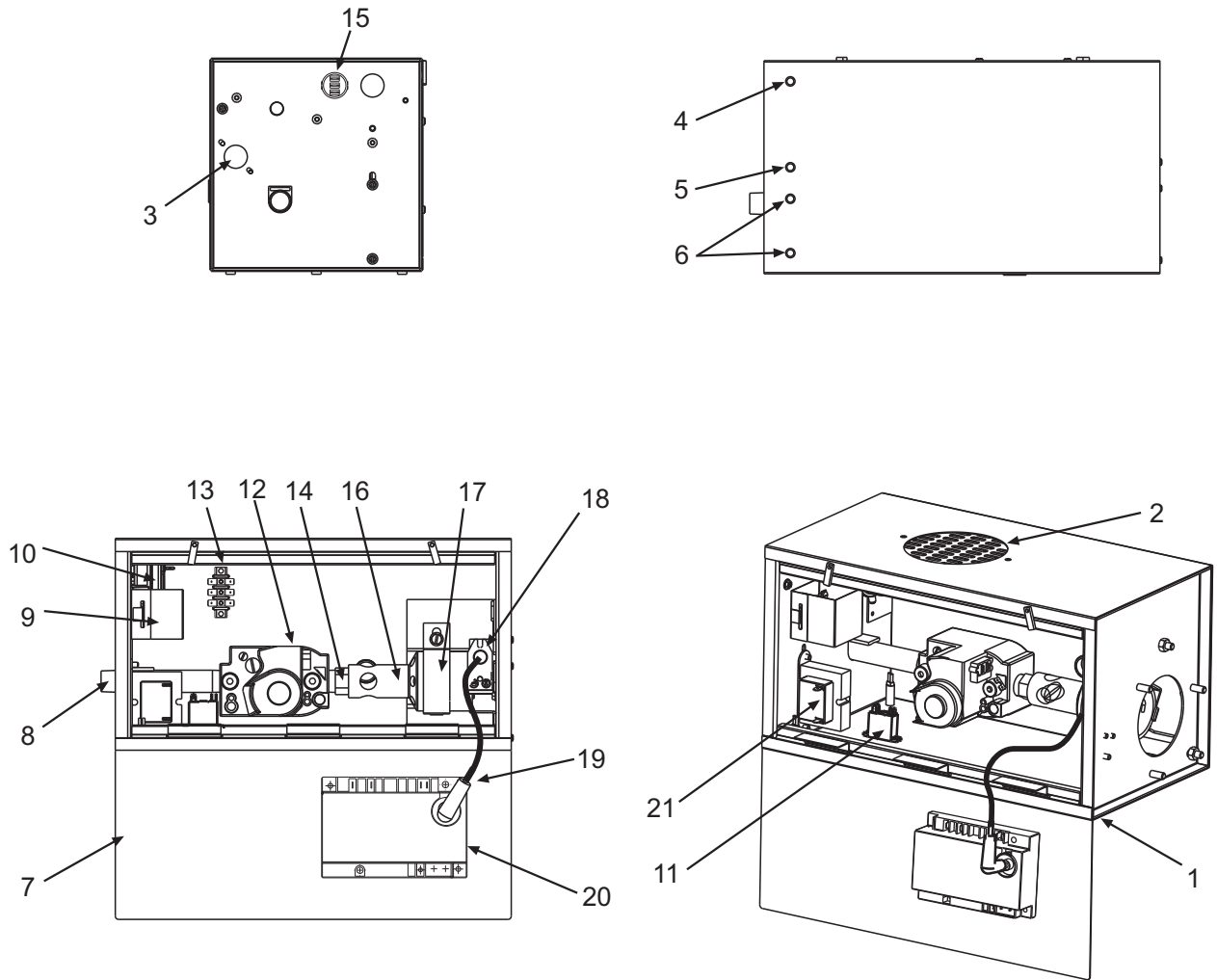

1	Cabinet Assembly	12	Gas Valve
2	Air Inlet Plate	13	3-Pole Terminal Block
3	Sight Glass	14	Orifice
4	Monitoring Light, Green	15	Thermostat Connection Block
5	Monitoring Light, Red	16	Main Burner
6	Monitoring Light, Amber (2)	17	Burner Clamp
7	Access Panel	18	Spark Electrode
8	Restrainer Nipple, 5" Long	19	Ignition Cable
9	Terminal Block and Shield	20	Ignition Module
10	Air Switch	21	Transformer (120/24 VAC)
11	Relay		

NOTE: Access panel only opens to 90°.

19.0) CLEANING AND ANNUAL MAINTENANCE

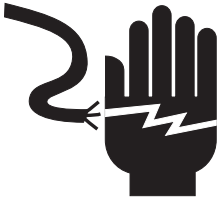
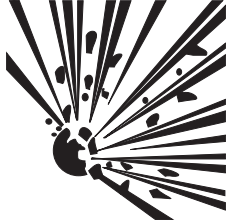
⚠ WARNING		
		<p style="text-align: center;">ELECTRIC SHOCK & EXPLOSION HAZARD</p> <p>Disconnect electrical power and gas supply before servicing.</p> <p>Failure to do so may result in death or serious injury.</p>

This heater must be cleaned and serviced annually by a qualified contractor before the start of each heating season and at any time excessive accumulation of dust and dirt is observed. Maximum heating efficiency and clean combustion will be maintained by keeping the heater clean. To clean the heater, turn off all electrical and gas supply to the heater.

The contractor shall check the following during periodic maintenance.

- **Clearances to combustibles:** Check that clearances are being maintained. Make sure there are no flammable objects, liquids or vapors near the heater. See also Section 4.0).
- **Reflectors:** Reflectors should be kept clean, at a minimum blow off the reflectors. (Dirty reflectors may reduce heat output).
- **Heat exchanger tubes:** Inspect the heat exchanger tubes to make sure they are not cracked, sagging or showing signs of fatigue.
- **Combustion air intake:** Disconnect combustion air intake from the control box and inspect internally using a flashlight to make sure no foreign material has collected in the tubes and that there is no obstruction around the air intake openings. Clean any foreign materials. Inspect any joints to make sure they are completely sealed. See also Section 15.0).
- **Venting System:** Disconnect vent pipe and inspect internally using a flashlight to make sure no foreign material has collected in the pipes. Check the external vent cap and make sure that there is no obstruction around the exhaust openings. Clean any foreign materials. Inspect any joints to make sure they are completely sealed. See also Section C.
- **Gas lines:** Make sure that the gas lines are not leaking. Check the gas connection to the heater for any signs of damage, fatigue or corrosion. If there are any signs of damage to the gas connection or leaks found in the gas piping, immediately stop using the heater until the gas pipe and connections have been repaired or replaced. Check that the gas lines are not bearing the weight of the heater. See also Section 11.0).
- **Control Box:** In order to extend the longevity of the heater, the heat exchanger tube and the burner must be level. Check that the control box is level. Clean the access panel, and the inside of the control box.
- **Blower wheel and housing:** Check that the blower wheel spins freely, blow out any dust or dirt with compressed air. A dirty wheel can reduce the volume of air pulled and can result in premature tube failure.
- **Electrode condition:** Visually check that the electrode gap is maintained at 3/16" and that the tips of the flame sensor and spark electrode are free from deposits. Clean off any deposits. Check that the electrode ceramic is free from cracks. **CAUTION: The ceramic portion of the electrode is very fragile so any cleaning or adjustments must be done with care.** See Section 21.1).
- **Suspension system:** Check that the suspension system is holding the heater level. Make sure that the heater is hanging securely, look for any evidence where the heater may have been hit accidentally and tighten any loose hanging points. Check that S hooks are closed. Check that there is no evidence of wear on the chain at the connection to the heater and at the ceiling.
- **Main Burner and Orifice:** Check the Main burner and orifice; remove any dirt or debris including spider webs. See Section 21.1).

Troubleshooting continued from the previous page.

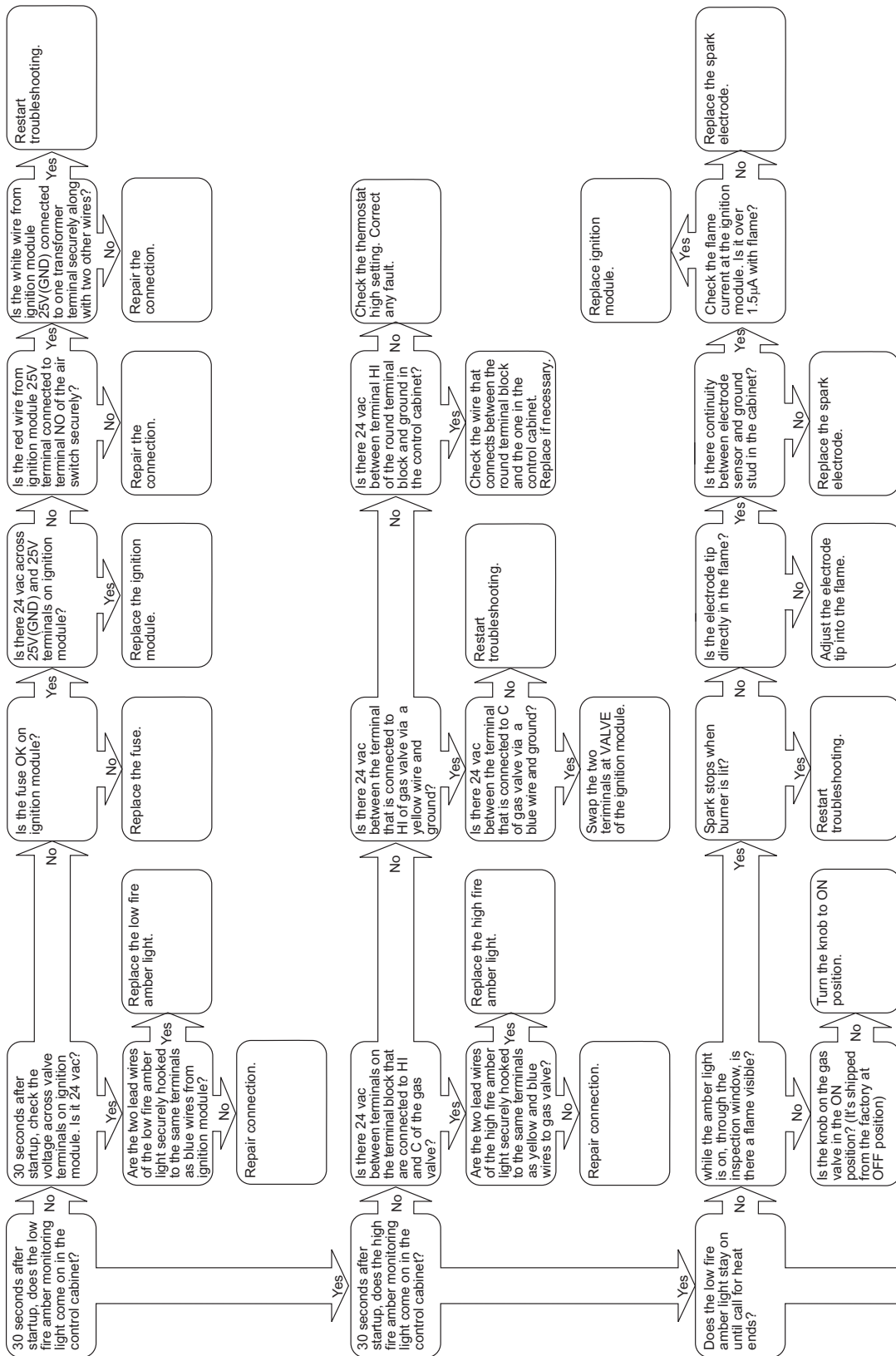

Troubleshooting continued on the next page.

See sequence continued on the next page. **3**

Troubleshooting continued from the previous page.

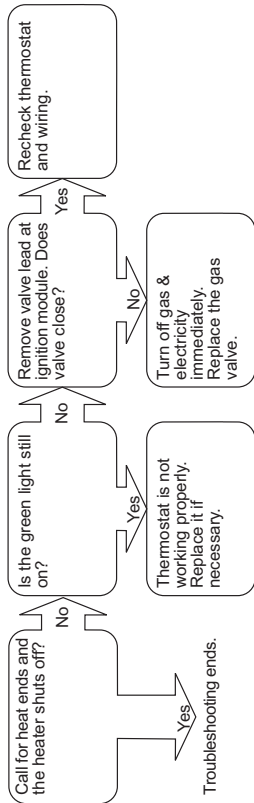

Troubleshooting continued from the previous page.

1

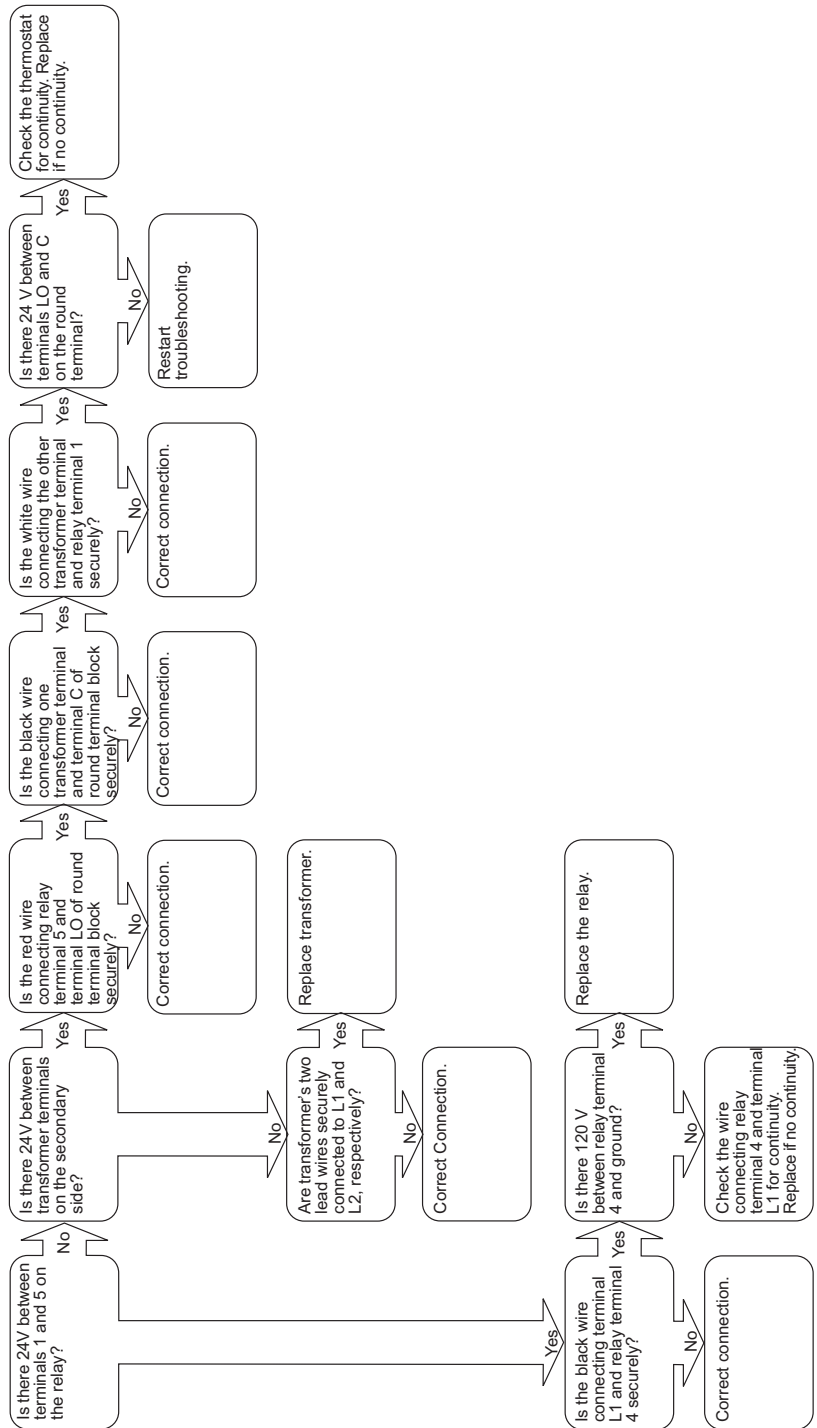

Troubleshooting continued from the previous page.

2

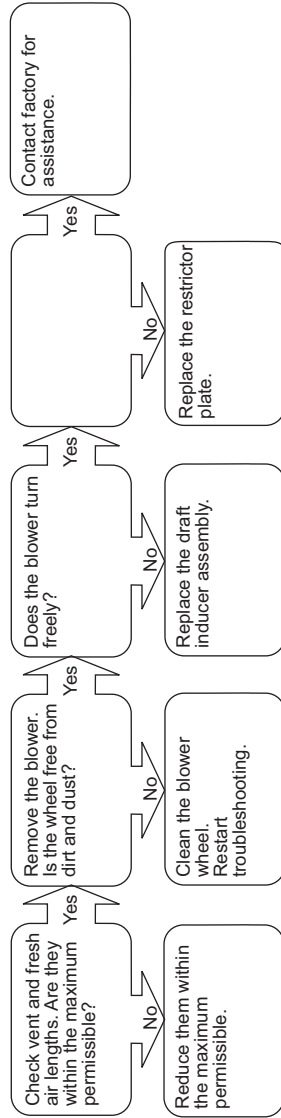

Troubleshooting continued from the previous page.

3

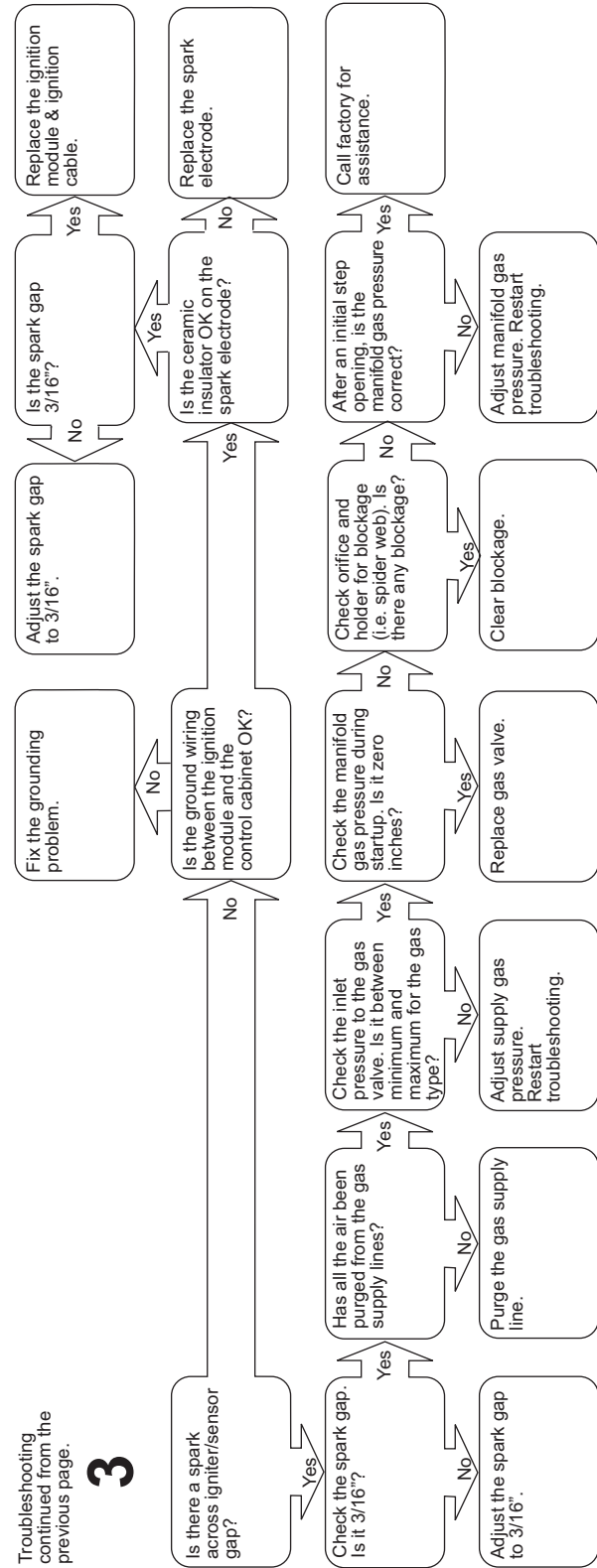

21.0) REPLACING PARTS

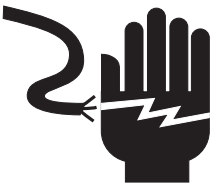
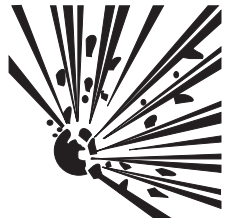
⚠ WARNING		
		ELECTRIC SHOCK & EXPLOSION HAZARD Disconnect electrical power and gas supply before servicing. Failure to do so may result in death or serious injury.

Only use genuine Space-Ray replacement parts. Parts are available from the factory for replacement by a licensed person. Refer to the Replacement Parts Guide in Section 23.0) for all replacement parts.

21.1) REMOVAL OF SPARK ELECTRODE

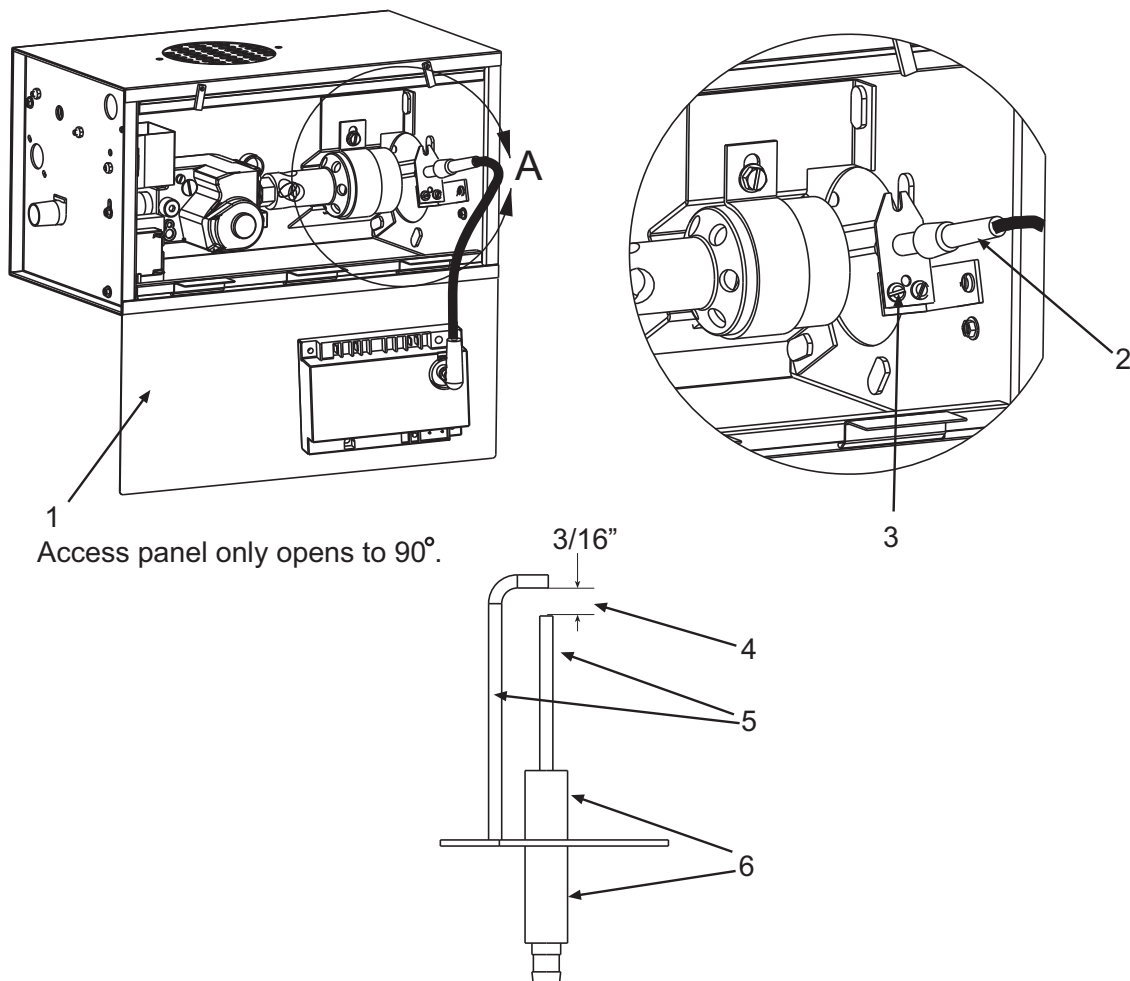

1. Disconnect electrical supply and open access panel.
2. Pull out the ignition cable hooked to spark electrode.
3. Remove two mounting screws.
4. Take out the spark electrode. Check that the spark gap is 3/16".
5. Check spark electrode. Spark electrode should be clean and free from debris.
6. Check ceramic on the spark electrode. It should be free from cracks.

21.2) REMOVING MAIN BURNER AND GAS VALVE

The main burner can be inspected without removing the burner housing from the heat exchanger tube.

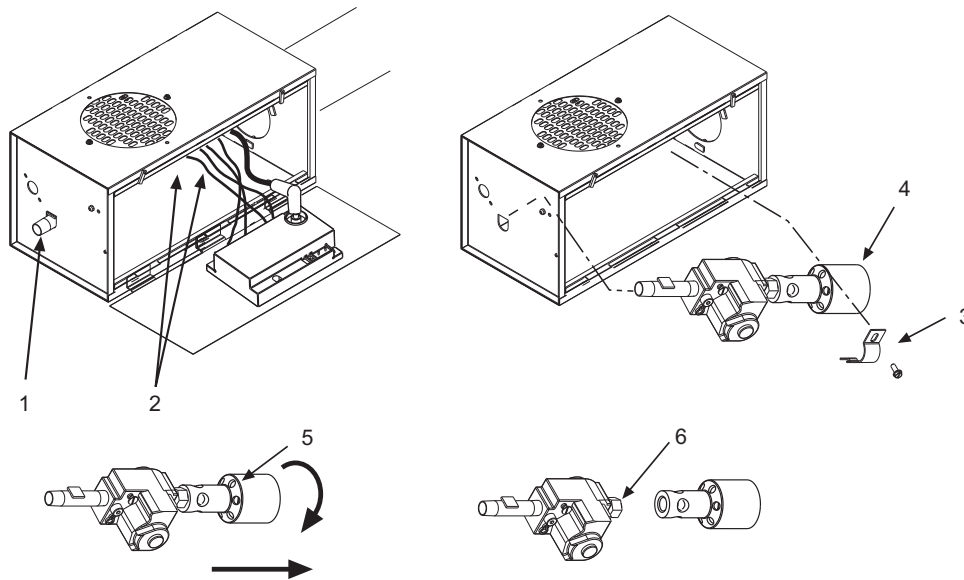

1. Disconnect electrical supply and gas connection at the restrainer nipple.
2. Open the access panel and disconnect the wires from gas valve.
3. Remove the burner clamp and screws.
4. Remove the burner and gas valve assembly from the cabinet.
5. Unscrew the burner from the manifold.
6. Check the orifice. If the gas valve is to be replaced, the pipe joint compounds must be resistant to the action of liquefied petroleum gases.

21.3) AIR SWITCH PRESSURE CHECK

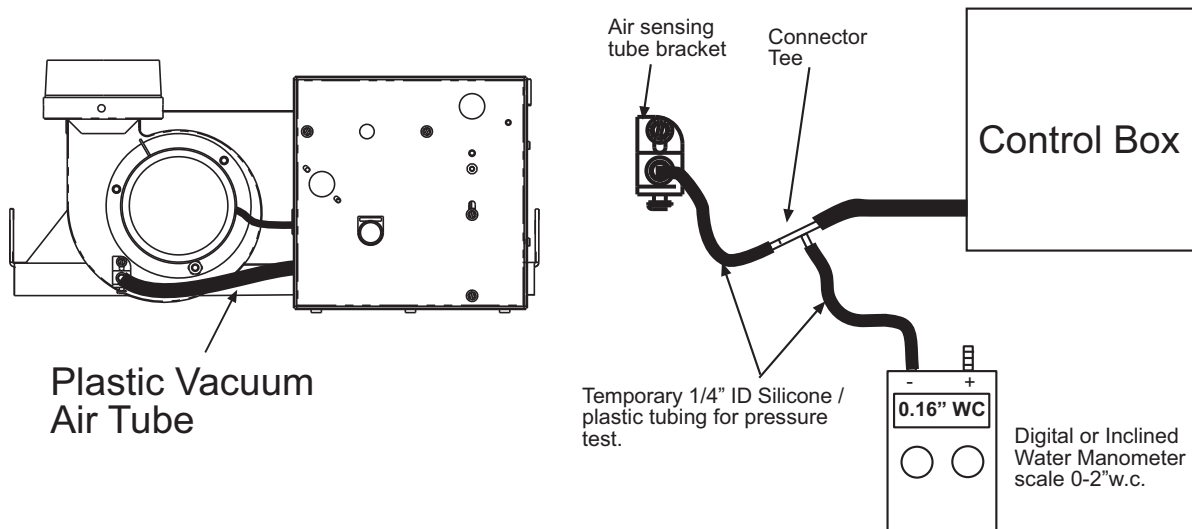

1. Open hinged access panel.
2. Add tubing to connect the air switch with the connector tee and the existing tubing.
3. Connect plastic tubing of a digital or inclined water manometer with a 0-2" scale onto the connector tees.
4. Turn heater on and wait until blower motor is activated.
5. Observe air pressure from manometer. This should be higher than the set point 0.16" w.c. for correct operation.

All pressures are with the heater in operation for at least 15 minutes.

21.4) IGNITION SYSTEM CHECKS

TO CHECK IGNITION CABLE.

- Make sure that the ignition cable does not touch any metal surface.
- Make sure that connections to the stud terminal and the igniter/sensor are clean and tight.
- Make sure that the ignition cable provides good electrical continuity.

TO CHECK IGNITION SYSTEM GROUNDING.

(Nuisance shutdowns are often caused by a poor or erratic ground.) A common ground is required for the module, igniter, flame sensor and main burner.

- Check for good metal-to-metal contact between the igniter bracket and the main burner.
- Check the ground lead from the GND (BURNER) terminal on the module to the igniter bracket. Make sure connections are clean and tight. If the wire is damaged or deteriorated, replace it.
- Replace igniter/sensor with factory replacement part if insulator is cracked.

TO CHECK SPARK IGNITION CIRCUIT.

▲ WARNING: The ignition circuit generates a 20,000 Volt open circuit and electrical shock can result.

- Check ignition cable.
- Check external fuse on the module.
- Verify power (24V) at module input terminals and output terminal to gas valve.
- Replace spark module if fuse and power are OK.

IGNITION MODULE DIAGNOSTICS (Fenwal #35-6087J1-034 module only)

The **LED** located on the ignition module will flash **ON** for ¼ second, then **OFF** for ¼ second during a fault condition. The pause between fault codes is 3 seconds.

LED Indication	Error Mode
Steady On	Internal Control Fault
2 Flashes	Flame Sense Fault
3 Flashes	Ignition Lockout

TO CHECK FLAME SENSOR CIRCUIT (Fenwal #35-6087J1-034 module only)

The flame current is the current that passes through the flame from the sensor to the ground. The minimum flame current necessary to keep the system from lockout is **0.7** micro-amps.

- To measure the flame current, connect an analog DC micro-ammeter to the **FC-** and **FC+** terminals per diagram. The meter should read **0.7** micro-amps or higher when the burner is running full on.
- If the meter reads below **zero**, the meter leads are reversed. Disconnect power and reconnect the meter leads for proper polarity.
- Remove micro-ammeter. Return system to normal operation.

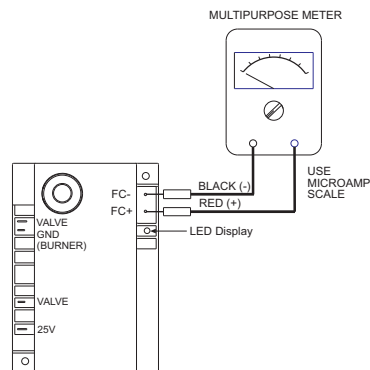

Ignition Module - Alternate
(Fenwal #35-6087J1-034)

21.5) MOTOR AND BLOWER WHEEL CHECK

If draft inducer motor fails to run:

- a. Check power supply to junction box.
- b. Check for loose or broken motor lead wire.
- c. Check to see that blower wheel turns freely and is not rubbing housing. Blower wheel may have worked loose from shaft and jammed against housing.
- d. Check for blower wheel damage; replace if necessary. If no damage, readjust blower wheel on shaft & retighten set screw.
- e. If all above does not correct, replace motor.

22.0) INSTALLATION DATA

Date of Installation: _____ # of Heaters in System: _____

Serial No. _____

Model: **LTU** _____

N = Natural Gas
L = Propane Gas

23.0) REPLACEMENT PARTS GUIDE

DRAFT INDUCER COMPONENTS			
Item No.	Part No.	Description	Qty.
1	42737000	Draft Inducer Assembly	1
1a	42928000	Motor Replacement Kit	1
2	03721000	Motor	1
3	30347000	Motor Spacer (4 per motor)	4
4	42740000	Motor Plate	1
5	03723000	Blower Wheel	1
6	43221000	Draft Inducer Gasket	1
7	42744000	Sensing Tube, Draft Inducer	1
8	42742000	Sensing Tube Bracket	1
9	42739000	Blower Housing Sub-Assembly	1
10	40504020	4" O.D. Flue Pipe Starting Collar	1
11	42741040	Restrictor Plate, 1" I.D. (40,000 Btu/hr)	1
12	42741030	Restrictor Plate, 1-1/8" I.D. (50,000 Btu/hr)	1
13	42741020	Restrictor Plate, 1-7/32" I.D. (60,000 Btu/hr)	1
14	42741010	Restrictor Plate, 1-7/16" I.D. (75,000 Btu/hr)	1

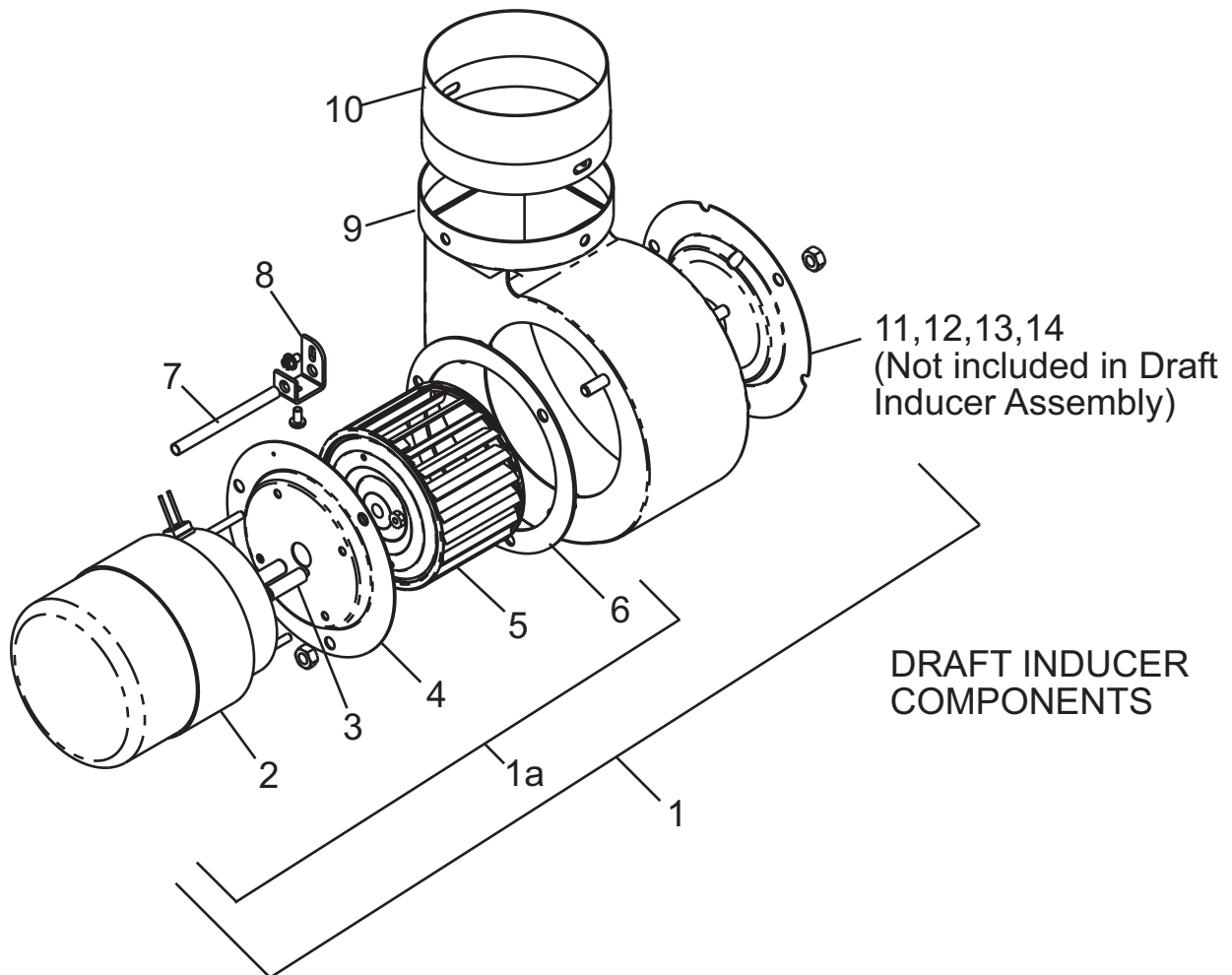

CONTROL COMPONENTS			
Item No.	Part No.	Description	Qty.
15	03988150	Plastic Vacuum Air Tube, 15" long	1
16	42750000	Cabinet Assembly	1
17	42751000	Access Panel	1
18	42752000	Air Inlet Plate (Perforated)	1
19	42447000	Sight Glass	1
20	42837040	Air Switch Kit, set @0.11" W.C., #NS2-0307-00	1
21	30383000	Relay, 24 V, SPST-NO	1
22	30279980	Transformer, AT120B1051	1
23	42709000	Terminal Block Shield	1
24	30281000	Terminal Block, EK-204	1
24a	30743000	Terminal Block, EL-3008	1
24b	30738030	Thermostat Connection Block - 3 Pole	1
25	42759000	Electrode Bracket	1
26	30295000	Electrode PSE-GF1 (Igniter/Sensor)	1
27	30314070	Ignition Cable, 7" long	1
28	30632060	Spark Module - Fenwal #35-608711-034	1
29	42398040	Monitoring Light, Green	1
30	42398060	Monitoring Light, Red	1
31	42398050	Monitoring Light, Amber	1
32	42757000	Restrainer Nipple, 5" long	1
33	30333250	Valve, VR8205Q-3819 @3.5" W.C./1.4" W.C. (Natural Gas, 40-75M Btu/hr Models)	1
34	30333260	Valve, VR8205Q-3827 @10" W.C./4" W.C. (Propane Gas, 40-75M Btu/hr Models)	1
35	42701000	Orifice Fitting & Test Gauge Connection	1
37	03259XXX	Orifice for LTU 40-75 (State Model & Gas Type for Size)	1
38	42700000	Main Burner	1
39	30148000	Universal Bushing, 7/8"	1
40	42755000	Burner Bracket Sub-Assembly	1
41	42753000	Burner Clamp	1

Labels / Manual			
Item No.	Part No.	Description	Qty.
42	42785030	Label, Ladder Wire Diagram	1
43	42706020	Label, Connection Wire Diagram	1
44	42710010	Installation and Operation Instructions (not shown)	1
45	43344050	Label, Gas Connector Warning	1
46	43344000	Label, Clearance to Combustibles	1
47	42848110	Label, Nameplate	1
48	42013000	Label, "Space-Ray" Logo	1
49	42922020	Label, Side Wall Venting	1
50	42834000	Label, 120V Caution	1
51	42875000	Label, Warning	1
52	43269060	Label, Thermostat Connection	1
53	43269070	Label, 2-Stage	1

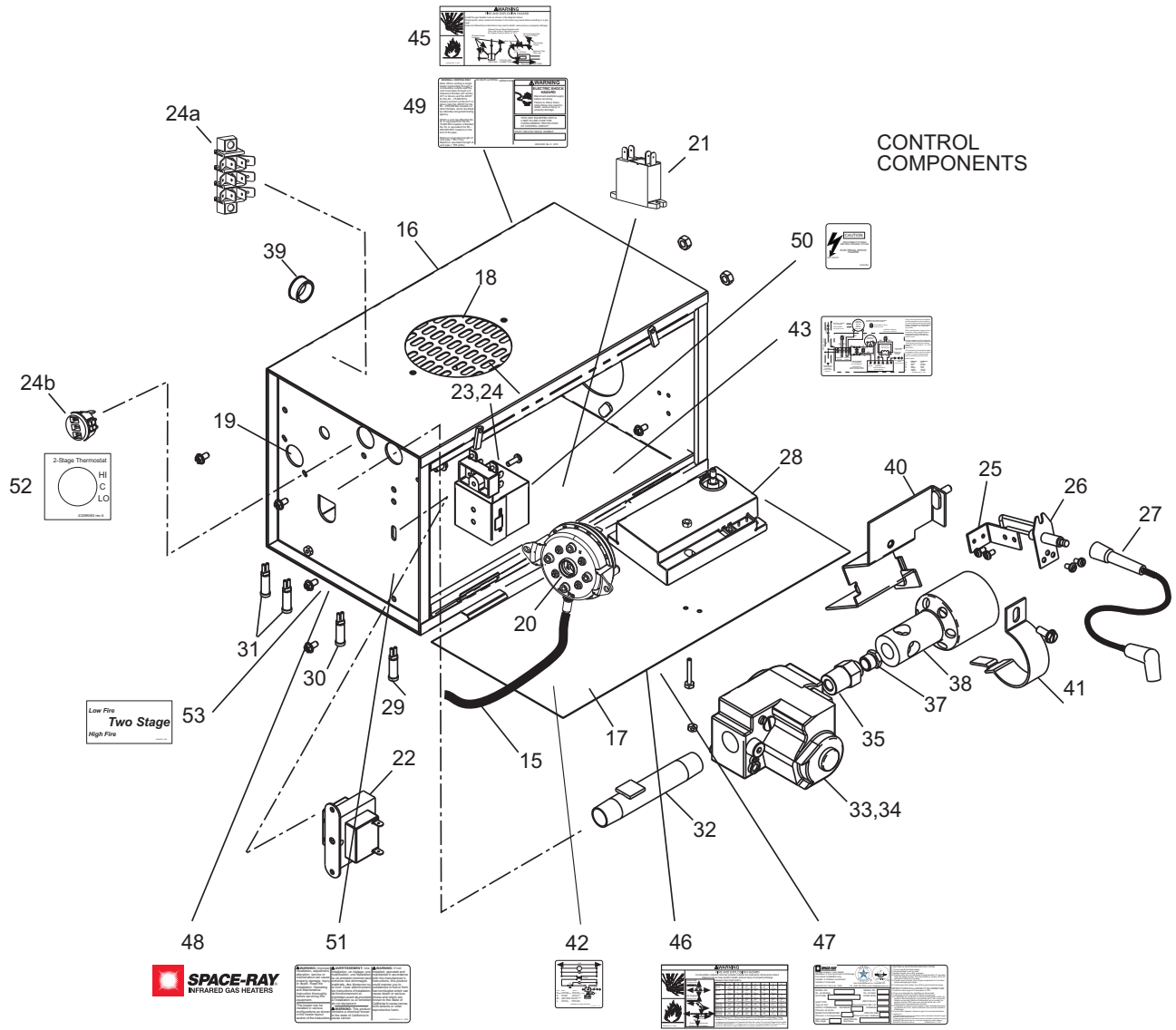

BODY COMPONENTS		
Item No.	Part No.	Description
1	02266010	Reflector Speed Clip
2	42769011	Reflector Clamp with screw (6 per heater)
3	42770000	"U" Bolt Clamp, 3" OD Tube (6 per heater)
3a	02127110	"U" Bolt Hex Nut, 5/16-18 (2 per "U" Bolt)
4	42773000	Tube Support/Hanger Bracket, 18-1/2" (3 per heater)
5	42763080	Reflector, 8' long (2 per heater)
6	42762010	Reflector, control end
7	42761010	Reflector, foot end
8	44028140	15' Tube Replacement Kit, 3" OD, ALC w/one 3-hole flange (Firing tube) –for LTU40-75
9	44028180	15' Tube Replacement Kit, 3" OD, ALC w/one 6-hole flange (Exhaust tube)–for LTU40-75
10	42764000	U Bend, 3" OD x 3-3/4" centerline radius
11	02251040	Set Screw, 5/16-24 x 1/2" (2 per heater)

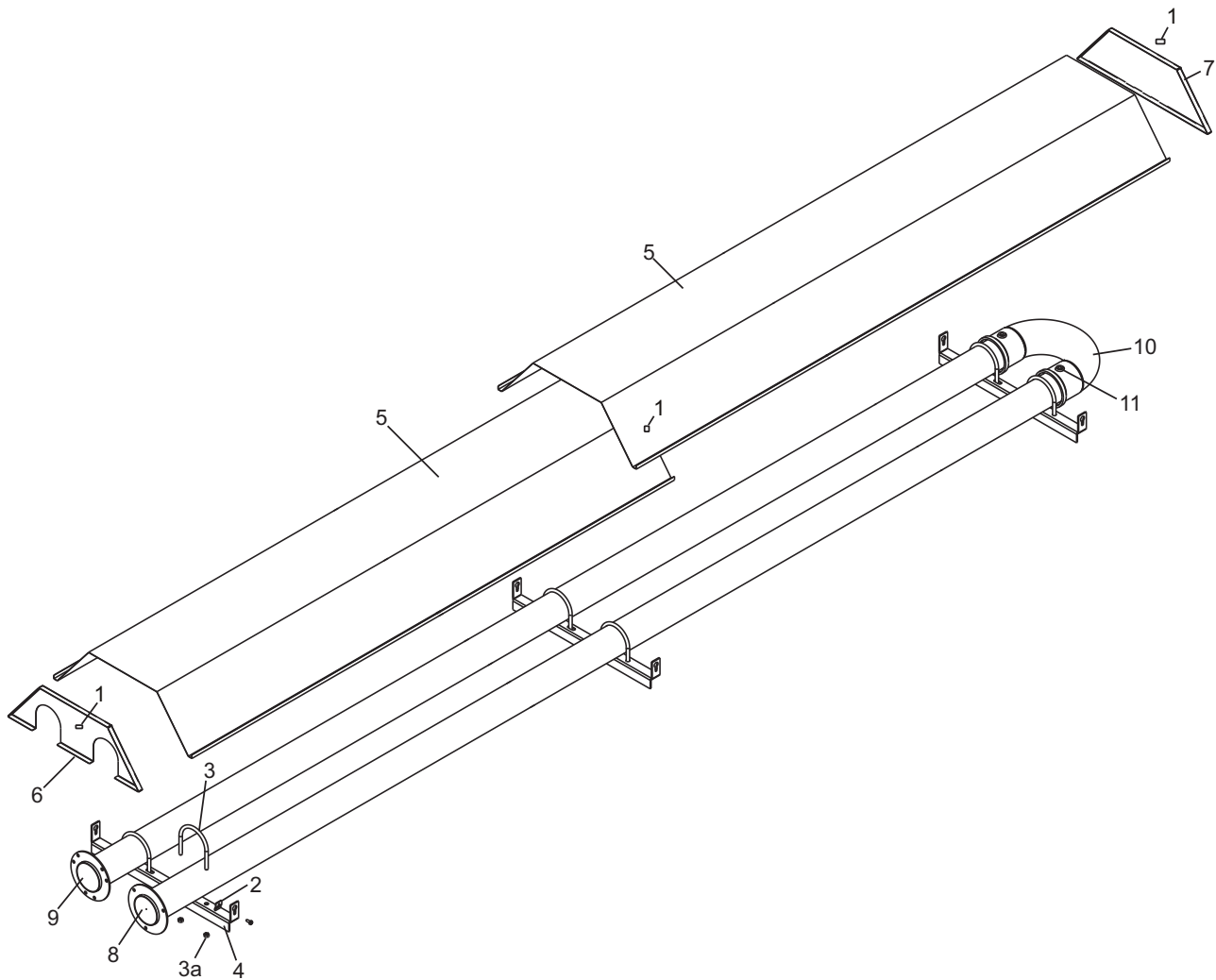

Note:

- 1) Screws, Nuts and Washers are standard hardware items and can be purchased at any local hardware store.
- 2) Please order by PART NUMBER – not by Item Number.
- 3) Replacement Part Prices are available when ordering.
- 4) Please refer to complete Model Number when ordering.

ALL ILLUSTRATIONS ARE INTENDED TO GIVE THE GENERAL IMPRESSION OF UNITS ONLY. WE RESERVE THE RIGHT TO ALTER ANY SPECIFICATION WITHOUT NOTICE.