

SPACE-RAY®

HIGH PRESSURE MODULATING CONTROL PANEL

MODELS: FOR SHP17 (-6) MODULATING BROODERS

INSTALLATION AND OPERATION INSTRUCTIONS

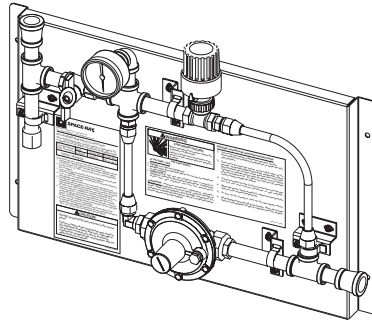

OWNER/INSTALLER: For your safety this manual must be carefully read before installing, operating or servicing this brooder. This brooder is intended for use with Propane Gas. It must be installed by a qualified service person or a licensed contractor in accordance with state and local codes. In the absence of these codes, the installation must conform to the National Fuel Gas Code ANSI Z223.1 (latest edition) also know a NFPA54 or the CAN/CGA-B149.1/2 Installation Code in Canada.

▲WARNING: Improper installation, adjustment, alteration, service or maintenance can cause injury, property damage or death. Refer to this manual. For assistance or additional information, consult a qualified installer, service agency or the gas supplier.

INSPECT all combustion air openings into the building and, if necessary, clear as they become blocked by litter, dust, feathers or other matter.

INSPECT and clean the brooder on a regular basis to allow proper brooder operation.

FOR YOUR SAFETY: EXHAUST FANS **MUST** be operating on an appropriate cycle when brooders are operating to avoid a high concentration of carbon monoxide. When used without fresh air, this brooder may give off carbon monoxide, an odorless and poisonous gas. **CARBON MONOXIDE POISONING MAY LEAD TO DEATH.** Early signs of carbon monoxide poisoning resemble the flu with headaches, dizziness and nausea. If you experience these signs, **GET FRESH AIR IMMEDIATELY!** Have the brooders serviced as soon as possible and check the ventilation in the house.

These brooders are designed for agricultural applications and may operate with Liquid Propane (LP) Gas Only.

IF YOU SMELL GAS:

- ! **DO NOT** try to light any appliance.
- ! **DO NOT** touch any electrical switch; do not use any telephone in your building.
- ! **IMMEDIATELY** call your gas supplier from a neighbor's telephone. Follow the gas supplier's instructions. If you cannot reach your gas supplier, call the fire department.

FOR YOUR SAFETY

DO NOT store or use gasoline or other flammable vapors and liquids in the vicinity of this or any other appliance.

**SAVE THIS MANUAL
FOR FUTURE REFERENCE.**

TABLE OF CONTENTS

<u>Section</u>	<u>Description</u>	<u>Page</u>
1)	GENERAL INFORMATION	1
2)	CONTROL SPECIFICATIONS.....	1
3)	INSTALLATION.....	2
4)	GAS CONNECTIONS	2
5)	INSTRUCTIONS FOR TESTING FOR GAS LEAKS AND PROPER GAS PRESSURE	3
6)	LIGHTING AND SHUTDOWN INSTRUCTIONS.....	4
7)	REPLACEMENT PARTS GUIDE.....	5

1. GENERAL INFORMATION

Installation of the Modulating Gas Control Panel must be in accordance with all applicable codes shown in the instructions and/or the local codes and authorities having jurisdiction. In the absence of local codes, the Modulating Gas Control Panel must be installed in accordance to the National Fuel Gas Code ANSI Z223.1/NFPA54 in the U.S. or the CAN/CGA-B149.1/2 Installation Code in Canada.

This control panel is intended for brooders that have a maximum gas pressure of 5PSIG and a minimum pressure of 10 in. w.c.

CAUTION

DO NOT Exceed 5 PSI inlet pressure to the control panel.

Failure to follow these instructions may result in the following: Invalidate Warranty, Damage to the brooder components due to overfiring, significantly increased gas consumption and hot spots below the heaters.

Copies of the National Fuel Gas Code (ANSI Z223.1-latest edition) are available from the CSA at 8501 E. Pleasant Valley Rd., Cleveland, OH 44131 or 55 Scarsdale Road, Don Mills, Ontario M3B 2R3. All NFPA codes are available from the National Fire Protection Association, Batterymarch Park, Quincy, MA 02269.

2. CONTROL SPECIFICATIONS

GAS SUPPLY PRESSURE	<i>Propane Gas:</i>	5 PSIG	350 mbar
NO OF BROODERS	<i>SHP17 L6:</i>	40	40
MAXIMUM GAS CONSUMPTION	<i>Propane Gas:</i>	71.6 GPH	28.8 L/hr
TEMPERATURE RANGE	<i>Modulating thermostat</i>	59 to 100 °F	15 to 38 °C

3. INSTALLATION

1. Chose the location for the control panel using the following guidelines.
 - Control panel must be mounted to a flat stable wall inside the building.
 - Ensure that the control panel is located in a position where the inlet and outlet will be easily accessible for installation and future maintenance.
 - Position so that the thermostatic control is not exposed to direct outside air temperature from drafts.
2. Install the panel using the four PN 02240010 #12 3/4" screws supplied in the holes shown below.

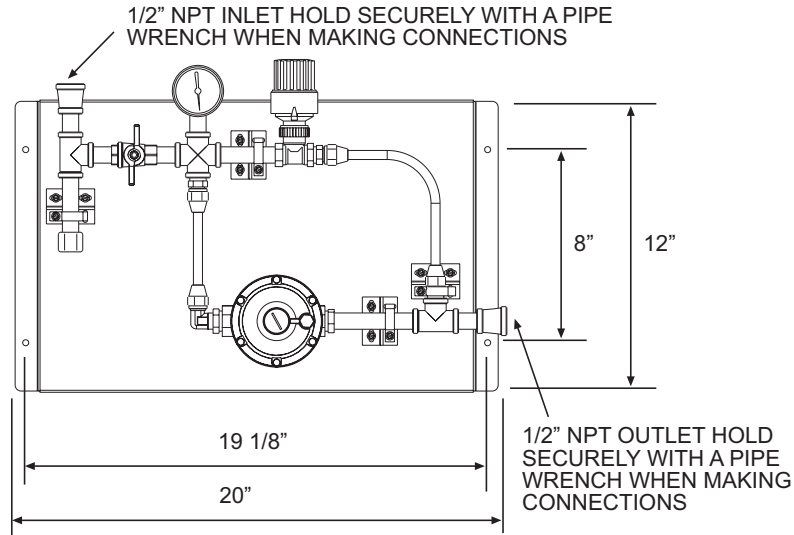

FIGURE 1

3. The thermostat control is supplied with a 26 ft (8m) thermostat bulb. The location of the bulb will depend on the layout of the area to be heated. It is recommended for best results to locate the bulb above the height of the livestock in an area to be heated at least 6ft (1.8m) from the brooder.

4. GAS CONNECTIONS

1. Gas piping for the house must be sized to be capable of satisfying the entire demands of the house should all equipment be operating at the same time. Please use the National Fuel Gas Code for the sizing of piping for the house.
2. Connect to the supply tank or manifold in accordance with the latest edition of the National Fuel Gas Code (ANSI Z223.1) and/or local codes. Authorities having jurisdiction should be consulted before the installation is made. Refer to the latest edition of CAN/CGA B.149-1/2 Installation Codes for Gas Burning Appliances and Equipment in Canada.
3. Pipe joint compounds must be resistant to the action of liquefied petroleum (LP) gases.
4. The Modulating Control Panel is intended to be used with a regulated supply pressure at 5 PSIG. The outlet pressure will modulate between 5 PSIG at maximum heat input and 10 in. w.c. for minimum heat input. The Modulating Control panel is designed to modulate the gas pressure to maintain a specific temperature.
4. Gas connections to the control panel are shown in figure 1 above.

5. INSTRUCTIONS FOR TESTING FOR GAS LEAKS AND PROPER GAS PRESSURE

▲WARNING: DO NOT OMIT THESE TESTS!

! WARNING	
	EXPLOSION HAZARD
	Before operating the brooders. Check the installation for gas leaks. Failure to follow these instructions may result in death, serious injury or property damage.

TESTING THE INSTALLATION FOR GAS LEAKS:

1. Inspect all connections and appliance valves to be sure connections are wrench-tight and that all appliance valves are closed, including the pilot valves.
2. Use the high pressure test gauge on the modulating control panel.
3. Fully open the LP gas container valve slowly to pressurize the piping system. Once the system is pressurized and stabilized, close the container valve tightly.
4. Observe the indicated pressure on the test set gauge. This reading should be approximately equivalent to the set delivery pressure of the final stage regulator. Now, slowly open one burner valve or pilot valve on the appliance to vent off just enough gas to reduce the pressure on the test gauge by 1 in. water column, then close the burner or pilot valve.

If the pressure remains unchanged on the gauge for at least 10 minutes, the system can be assumed leak-tight. If a drop in pressure does occur, it indicates a leak in the system.

If the pressure drop occurs, check the joints, connectors, and other possible points of leakage with an approved, high quality leak detection solution. **NEVER USE A MATCH OR OPEN FLAME TO CHECK FOR LEAKS.** Once a leak has been located and repaired, repeat Steps 3 and 4 above. If there is an increase in pressure, it indicates that the LP gas container valve is not shut off tightly. Shut off the valve tightly and repeat Step 4 above.

NOTE: Do not expose final stage piping to excessive heat or direct sunshine during the leak test. Pressure build-up in the line due to heat may compensate for pressure loss due to leaks. This will prevent the gauge reading from indicating system leaks.

▲WARNING: Gas Pressure Testing is to be performed only by qualified personnel.

CHECK GAS INLET (SUPPLY) PRESSURE:

1. Use the gas pressure gauge installed on the modulating control panel to check the supply pressure. Turn the shut off valve to the "ON" position and light the brooders with the thermostat set to the highest temperature to give maximum gas pressure. **DO NOT EXCEED 5PSI INLET PRESSURE TO THE BROODER.**

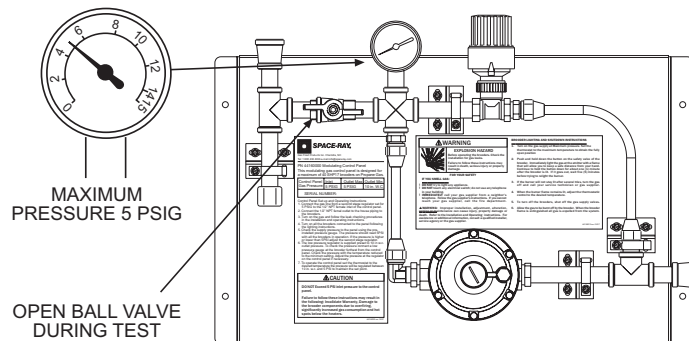

FIGURE 2

REGULATOR LOCK-UP AND LEAKAGE:

After the leak testing and delivery pressure tests have proven satisfactory, the regulator lock-up and leakage test may be performed. The lock-up pressure of the final stage regulator should be slightly higher than, but not more than, 120% of the set delivery pressure. For example, on a delivery pressure setting of 5 PSIG, the maximum allowable lock-up pressure is 6 PSIG.

To perform the lock-up and leakage test, follow these steps:

1. With the LP tank valve fully open, shut off all appliance valves so there is no demand for gas. This includes shutting off all pilots.
2. A slight rise in pressure will occur under these conditions. This rise should be no more than 120% of the delivery pressure. This is the lock up pressure. **NOTE:** A quick rise in pressure above the allowable lock-up point could indicate undersized piping, a worn regulator seat disc or foreign material in the regulator seating area. **This condition must be corrected before putting the system in service.**
3. Continue the test for five minutes or more. If a creeping rise in pressure is noticed, the final stage regulator seat is not closing off properly. The regulator must be replaced or repaired, and the system retested, before putting the system in service.

6. LIGHTING AND SHUTDOWN INSTRUCTIONS

1. Turn on the gas supply, set the thermostat control valve to the maximum temperature to obtain the fully open position
2. Push and hold down the button on the safety valve. Immediately light the gas at the emitter with a flame that will allow you to keep a safe distance from your hand. Continue to hold the button down for about one (1) minute after the brooder is lit. If it goes out, wait five (5) minutes before trying to relight the pilot. **NOTE: If the button does not pop up when released, stop and immediately call your service technician or gas supplier.**
3. If the burner will not stay lit after several tries, turn off the gas and call your service technician or gas supplier.
4. When the burner flame remains lit, adjust the thermostatic control to the desired temperature.
5. To turn off the brooders shut off the gas supply valves.
6. Allow the gas to be burnt off by the brooder. When the brooder flame is extinguished all gas is expelled from the system.



GAS-FIRED PRODUCTS LIMITED WARRANTY

LIMITED WARRANTY

Gas-Fired Products, Inc. (GFP), the manufacturer, warrants the original owner of any Space-Ray Poultry Heating Product that it will be free from defects in material or workmanship under normal use and service. The heater(s) shall be installed, used and maintained strictly in accordance with the manufacturer's instructions. The manufacturer's sole obligation under this warranty is limited to furnishing replacement parts, F.O.B. Charlotte, NC, for 12 months from the date of installation, or 18 months from the date of shipment by the manufacturer, whichever period expires first. Labor charges for the removal of defective parts or the installation of replacement parts are not included.

WARNING: Manufacturer's warranty shall not apply: (a) to circumstances where gas pressure to each heater is higher than that specified for each heater; (b) to circumstances where the type of gas is different than the type of gas noted on the name plate for each heater; (c) to water damage to gas controls; and (d) to any heater or component which has been repaired or replaced with other than factory parts, modified in any way, misused or damaged, or which has been used contrary to the manufacturer's written instructions.

LIMITATION OF WARRANTY: THERE ARE NO WARRANTIES, EXPRESS OR IMPLIED, WHICH EXTEND BEYOND THE DESCRIPTION ON THE FACE HEREOF. WITHOUT LIMITING THE FOREGOING, THE MANUFACTURER EXPRESSLY EXCLUDES ANY AND ALL IMPLIED WARRANTIES, INCLUDING BUT NOT LIMITED TO ANY IMPLIED WARRANTY OF FITNESS FOR A PARTICULAR PURPOSE AND ANY IMPLIED WARRANTY OF MERCHANTABILITY FOR ITS PRODUCTS.

If any provision of this warranty is found to be void, unenforceable or unconscionable, then that portion is hereby severed and the remainder of this warranty is hereby saved and shall remain in force.

EXCLUSIVE REMEDY: The sole and exclusive remedy under this warranty is the replacement of the defective parts or brooders as hereinabove specified. THE MANUFACTURER DOES HEREBY EXPRESSLY EXCLUDE ANY AND ALL LIABILITY FOR INCIDENTAL OR CONSEQUENTIAL DAMAGES UNDER THIS OR ANY OTHER WARRANTY. Without intending to limit the aforesaid exclusion, THE MANUFACTURER DOES HEREBY EXCLUDE ANY LIABILITY UNDER THIS OR ANY OTHER WARRANTY FOR INJURIES OR COMMERCIAL LOSSES TO PROPERTY THAT RESULT FROM THE OPERATION, PROPER OR IMPROPER, OF ITS PRODUCTS.

ADDITIONAL TERMS: Manufacturer assumes no liability for delay in performing its obligations under this warranty. Manufacturer assumes no liability for failure in performing its obligations there under if failure results directly or indirectly from any cause beyond its control, including but not limited to acts of God, acts of Government, floods, fires, shortages of materials, strikes and other labor difficulties or delays or failures of transportation facilities.

This is a Non-Residential product. Installation and service shall be by a Licensed Contractor and in accordance with National and Local Codes.

When presenting warranty claims, proof of date of purchase must be submitted.

No Representative is authorized to assume for the manufacturer, any liability except as set forth above.

For the name of your nearest distributor in case of claim under this warranty, contact: Space-Ray / Gas-Fired Products, Inc. / 305 Doggett St., PO Box 36485 / Charlotte, NC 28236 / Phone: (704) 372-3485 / Fax: (704) 332-5843 / email: info@spaceray.com.

FOR YOUR RECORDS:

Space-Ray Control panel Number: _____ Date Installed: _____

Serial Numbers: _____

For replacement parts, please contact your local distributor or:

SPACE-RAY

305 Doggett Street • Charlotte, NC 28203-4923

Phone (704) 372-3485 • Fax (704) 332-5843 • info@spaceray.com