



## 1) GENERAL INFORMATION

This heater complies with ANSI Z83.6 (current standard) and CAN 1-2.16. Copies of the National Fuel Gas Code (ANSI Z223.1-latest edition) are available from the CSA at 8501 East Pleasant Valley Road, Cleveland, OH 44131 or 55 Scarsdale Road, Don Mills, Ontario M3B 2R3. All NFPA codes are available from the National Fire Protection Association, Batterymarch Park, Quincy, MA 02269.

This heater is a self-contained infrared radiant tube heater for use in locations where flammable gases or vapors are not generally present (as defined by OSHA acceptable limits) and is intended for the heating of nonresidential spaces.

### INSTALLATION REQUIREMENTS

The installation must conform to local building codes or, in the absence of local codes, with the National Fuel Gas Code ANSI Z223.1/NFPA54 or the Natural Gas and Propane Installation Code CSAB149.1. Heaters shall be installed by a licensed contractor or licensed installer. Clearances to combustibles as outlined in this manual should always be observed. In areas used for storage of combustible materials where they may be stacked below the heater, NFPA54 requires that the installer must post signs that will “specify the maximum permissible stacking height to maintain the required clearances from the heater to combustibles.”

Every heater shall be located with respect to building construction and other equipment so as to permit access to the heater. Each installer shall use quality installation practices when locating the heater and must give consideration to clearances to combustible materials, vehicles parked below, lights, overhead doors, storage areas with stacked materials, sprinkler heads, gas and electrical lines, and any other possible obstructions or hazards. Consideration also must be given to service accessibility.

The heater, when installed in aircraft hangars and public garages, must be installed in accordance with ANSI/NFPA 409-latest edition (Standard for Aircraft Hangars), ANSI/NFPA 88a-latest edition (Standard for Parking Structures), and ANSI/NFPA 88b-latest edition (Standard for Repair Garages) with the following clearances:

- a. At least 10 feet above the upper surfaces of wings or engine enclosures of the highest aircraft that may be housed in the hangar and at least 8 feet above the floor in shops, offices, and other sections of hangars communicating with aircraft storage or service areas.
- b. At least 8 feet above the floor in public garages. **WARNING:** Minimum clearances marked on the heater must be maintained from vehicles parked below the heater.

#### (FOR CANADA ONLY)

- a. Installation of this appliance is to be in accordance with latest edition of CAN 1-B149.1 (Installation Code for Natural Gas Burning Appliances and Equipment), and/or CAN B149.2 (Installation Code for Propane Gas Burning Appliances and Equipment).
- b. For installation in public garages or aircraft hangars, minimum clearances from the bottom of the infrared heater to the upper surface of the highest aircraft or vehicle shall be 50 percent greater than the certified minimum clearance, but the clearance shall not be less than 8 feet.

Although these heaters may be used in many applications other than space heating (e.g., process heating), Space-Ray will not recognize the warranty for any use other than space heating.

This heater is for Indoor Installation and Covered Patio Installation only and can be used in either Vented or Unvented mode. The term Unvented actually means Indirect Vented. While the products of combustion are expelled into the building, national codes require ventilation in the building to dilute these products of combustion. This ventilation may be provided by gravity or mechanical means.

This heater is not an explosion proof heater. Where the possibility of exposure to volatile and low flash point materials exists, it could result in property damage or death. This heater must not be installed in a spray booth where the heater can operate during the spraying process. Consult your local fire marshal or insurance company.

**ETS Series Only:** Since straight tube heaters are always hotter at the control end than at the draft inducer end, always observe the minimum recommended mounting heights shown on the specification sheets and in Section 2 of this manual. Use the U-tube configuration instead of straight tubes for spot or area heating (e.g., where a single heater is utilized for space heating).

**WARNING:** Certain materials or objects, when stored under the heater, will be subjected to radiant heat and could be seriously damaged. Observe the Minimum Clearances to Combustibles listed in the manual and on the heater at all times.

## 2) MINIMUM CLEARANCES TO COMBUSTIBLES

Minimum clearances to combustibles shall be measured from the outer surfaces as shown in the following diagram:

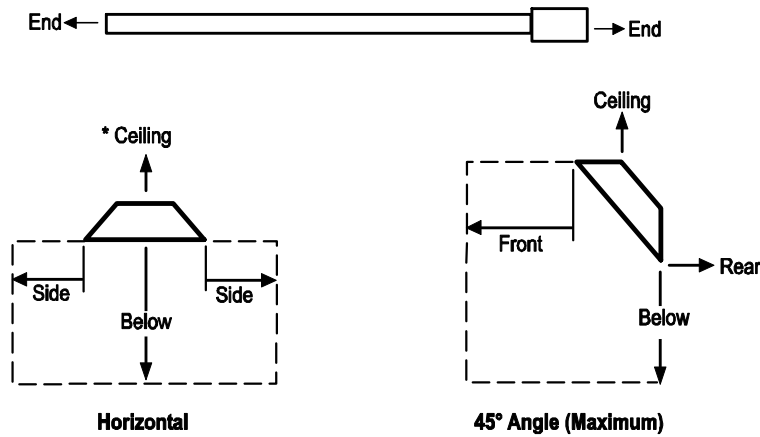

MINIMUM CLEARANCES TO COMBUSTIBLES						
Model No.	Mounted Horizontally				Angle Mounted at 45°	
	Sides	Ceiling <sup>□</sup>	Below	Ends	45° Front	45° Rear
ETS/ETU 40, 50	27"	6"	40"	30"	48"	12"
ETS/ETU 60, 75	27"	6"	60"	30"	48"	12"
ETS/ETU 80, 90	52"	6"	84" **	30"	52"	12"
ETS/ETU 100	66"	6"	88" **	40"	66"	20"
ETS/ETU 110, 120, 125, 130	66"	6"	101" **	41"	66"	20"
ETS/ETU 140, 150, 160, 175	84"	6"	106" **	48"	84"	24"
ETS/ETU 180, 200, 225, 250	84"	18"	132" **	48"	84"	24"

\* When used indirect vented, the clearance must be: 12" for ETS/ETU40-75 and 18" for ETS/ETU80-250. If optional corner reflectors are not used, the clearance must be 18".

\*\* Minimum Clearance BELOW reduces to 72" once you are 20 feet downstream from the control box.

**NOTE:** The clearances specified above must be maintained to combustibles and other materials that may be damaged by temperatures 90°F above ambient temperature. Clearances to combustibles are posted on the control box. In areas used for storage of combustible materials where they may be stacked below the heater, NFPA54 requires that the installer must post signs that will "specify the maximum permissible stacking height to maintain the required clearances from the heater to combustibles." Space-Ray recommends posting these signs adjacent to the heater thermostat or other suitable location that will provide enhanced visibility.

### 3) SPECIFICATIONS

Model No.	Btu/hr Input	Flue Restrictor Plate I.D. & Part #		Orifice Size				Minimum Mounting Height	
				Natural Gas		Propane Gas		@ Horizontal	@45° Angle
ETS/ETU40	40,000	1"	#42741040	#31	(0.120)	#49	(0.073)	10 feet	9 feet
ETS/ETU50	50,000	1-1/8"	#42741030	3.3mm	(0.130)	#46	(0.081)	11 feet	10 feet
ETS/ETU60	60,000	1-7/32"	#42741020	#27	(0.144)	#43	(0.089)	12 feet	11 feet
ETS/ETU75	75,000	1-7/16"	#42741010	#20	(0.161)	#39	(0.099)	13 feet	12 feet
ETS/ETU80	80,000	1-1/2"	#42741050	#19	(0.166)	#38	(0.102)	13 feet	12 feet
ETS/ETU90	90,000	1-1/2"	#42741050	#16	(0.177)	#36	(0.106)	13 feet	12 feet
ETS/ETU100	100,000	1-5/8"	#42741060	#14	(0.182)	#33	(0.113)	14 feet	13 feet
ETS/ETU110	110,000	1-3/4"	#42741070	#10	(0.194)	#31	(0.120)	13 feet	12 feet
ETS/ETU120	120,000	1-3/4"	#42741070	13/64	(0.203)	1/8	(0.125)	13 feet	12 feet
ETS/ETU125	125,000	1-7/8"	#42741080	#5	(0.206)	#30	(0.129)	13 feet	12 feet
ETS/ETU130	130,000	1-7/8"	#42741080	#4	(0.209)	3.3mm	(0.130)	15 feet	14 feet
ETS/ETU140	140,000	2-1/32"	#42741090	5.5mm	(0.216)	#29	(0.136)	15 feet	14 feet
ETS/ETU150	150,000	2-1/32"	#42741090	5.7mm	(0.224)	#28	(0.140)	15 feet	14 feet
ETS/ETU160	160,000	2-1/4"	#42741100	5.8mm	(0.228)	#27	(0.144)	16 feet	15 feet
ETS/ETU175	175,000	2-1/4"	#42741100	"C"	(0.242)	3.8mm	(0.150)	16 feet	15 feet
ETS/ETU180	180,000	2-1/4"	#42741100	"C"	(0.242)	#24	(0.152)	18 feet	17 feet
ETS/ETU200	200,000	2-3/8"	#42741130	"F"	(0.257)	#21	(0.159)	18 feet	17 feet
ETS/ETU225	225,000	2-1/2"	#42741140	6.9mm	(0.272)	#18	(0.170)	20 feet	19 feet
ETS/ETU250	250,000	2-3/4"	#42741150	"K"	(0.281)	4.5mm	(0.177)	20 feet	19 feet

- MOUNT HEATERS AS HIGH AS POSSIBLE. Minimums are shown as a guideline for human comfort and uniform energy distribution for complete building heating applications. Consult your Space-Ray representative for the particulars of your installation requirements.

Type Gas	Gas Pipe Connection <sup>1</sup>	Tube Diameter	Flue Connection <sup>2</sup>	Fresh Air Connection	Electrical Supply	Current Rating
Natural or Propane	1/2" MPT (Male)	4"	4" Round	6" Round	120 Volt, 60Hz, 1 Phase	2.6 Amp

<sup>1</sup> ETS/ETU 225 and 250 require a minimum 3/4" nominal ID flexible gas connector.

<sup>2</sup> ETS/ETU 180-250: 6" round. See Section 12 for vent sizes and limitations

Fuse Rating:		Ignition System (direct spark):
In-line: 2 Amp 250V (for 24V Circuit)	Spark Module: 3 Amp 250V (for 24V Circuit)	30 second pre-purge period

## 4) DIMENSIONS – ETS SERIES

Typical Dimensions Up to 50 Ft. Shown



Typical Dimensions Up to 50 Ft. Shown.

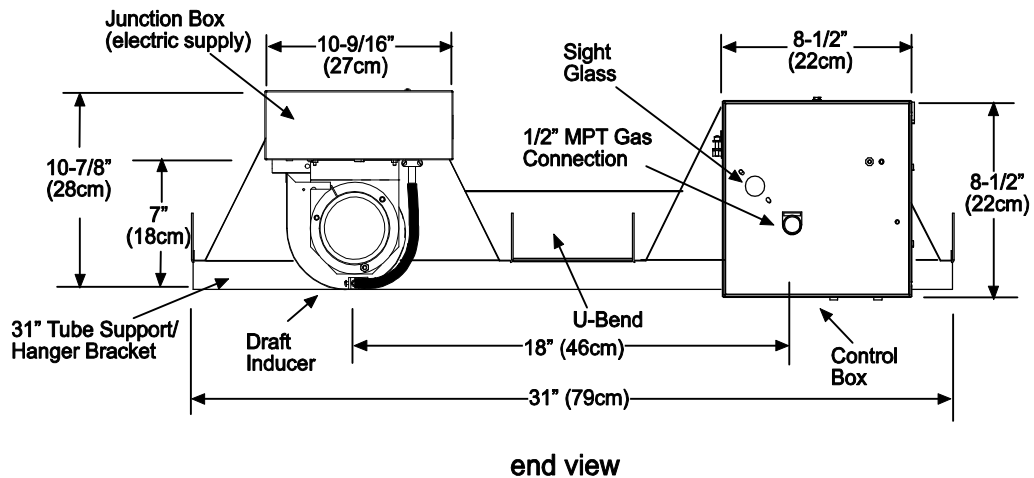
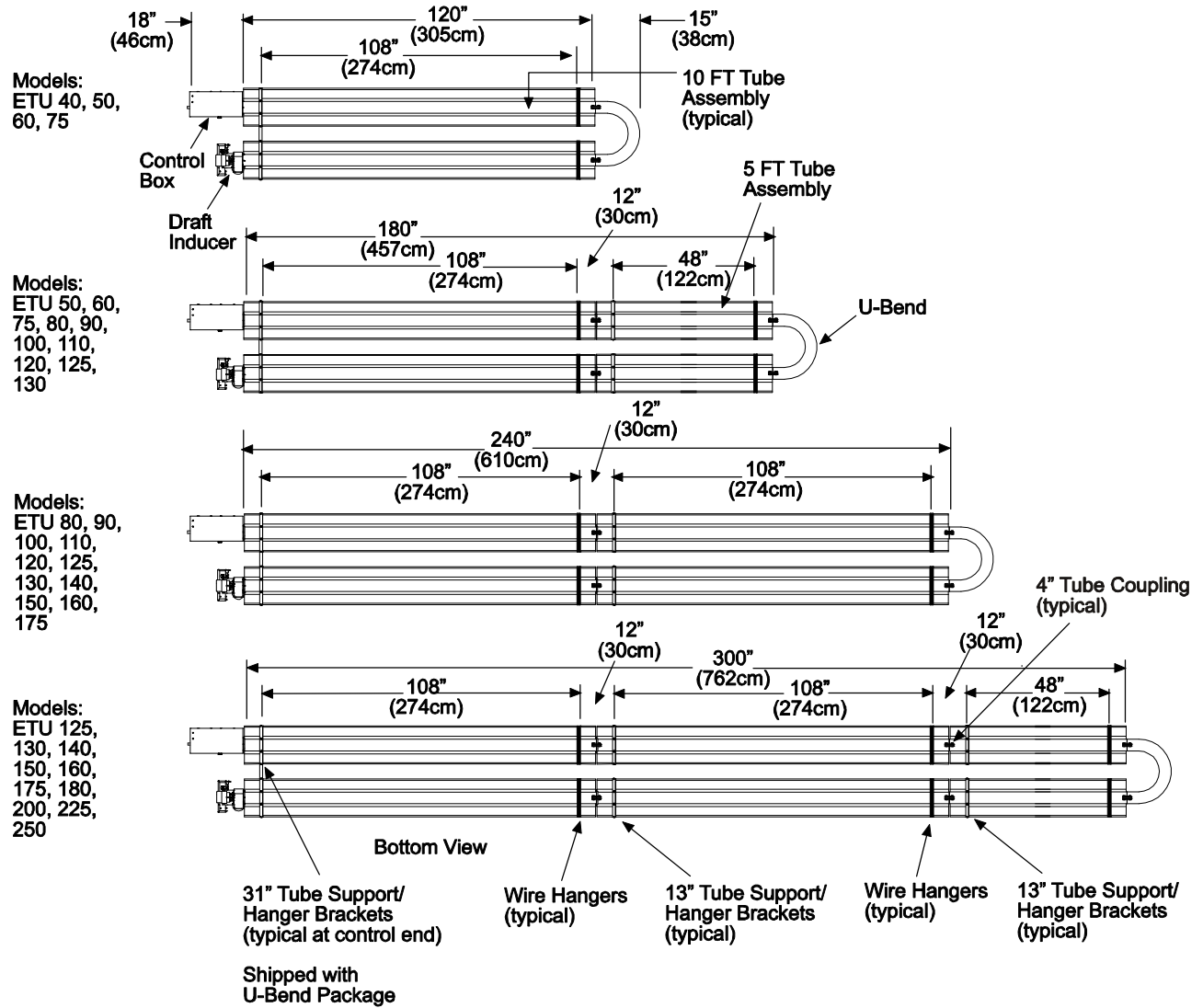

6) ACCESSORY PACKAGES

**A. End Reflector Accessory Package, Part #43341010**

*(1 pkg. per ETS Series or 2 pkgs. per ETU Series)*

**Contains:**

End Reflector, #43320000.....QTY-2

Speed Clips, #02266010.....QTY-4

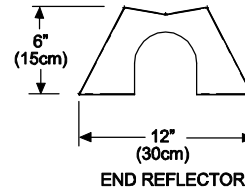

**B. Elbow Accessory Package, Part #43208010**

*(Option for ETS Series Only)*

**Contains:**

Elbow, #43175000.....QTY-1

#10-16 x 1/2 Self-Drilling Screws, #02189020.....QTY-2

Tube Coupling, #30462980.....QTY-1

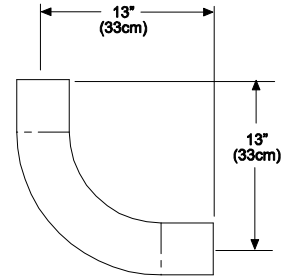

**C. Corner Reflector Accessory Package, Part #43342000**

*(Option for ETS Series Only)*

**Contains:**

Corner Reflector Assembly, #43345000.....QTY-1

Speed Clips, #02266010.....QTY-4

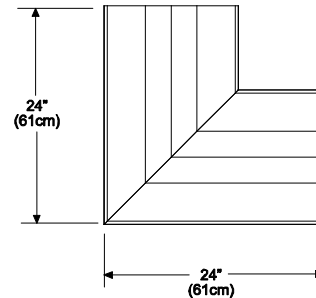

**D. U-Bend Package, Part #43208020**

*(Option for ETU Series Only)*

**Contains:**

U-Bend, #42913020.....QTY-1

#10-16 x 1/2 Self-Drilling Screws, #02189020.....QTY-2

Tube Coupling, #30462980.....QTY-1

31" Tube Support/Hanger Bracket, #43318500.....QTY-1

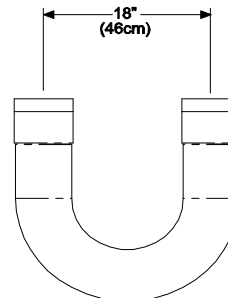

**E. Exhaust Hood Package, Part #42924000**

**Contains:**

Exhaust Hood Assembly, #42925540.....QTY-1  
 #8-18 x 1/2 Self-Drilling Screws,  
 #02189030.....QTY-2

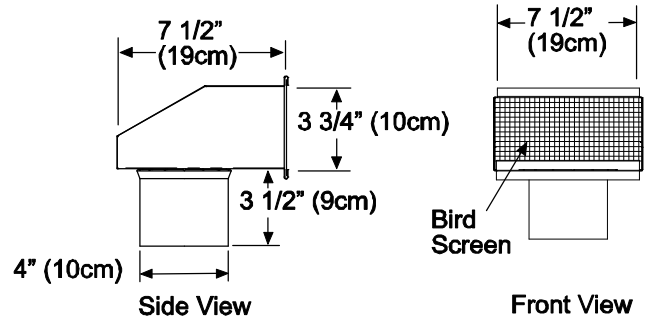

**F. U-Bend Reflector Package, Part #43488000**

*(Option for ETU Series Only)*

**Contains:**

U-Bend Reflector, #43490000.....QTY-1  
 U-Bend End Reflector, #43490050.....QTY-1  
 Speed Clips, #02266010.....QTY-11  
 #10-16 x 1/2 Self-Drilling Screws, #02189020.....QTY-4  
 Installation Form, #43489000.....QTY-1

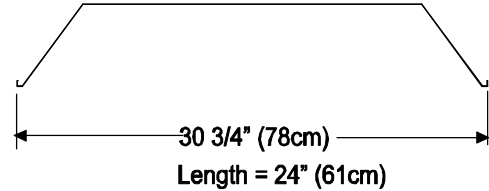

**G. 31\"/>**

*(Option for Angle Mounting of ETU Series)*

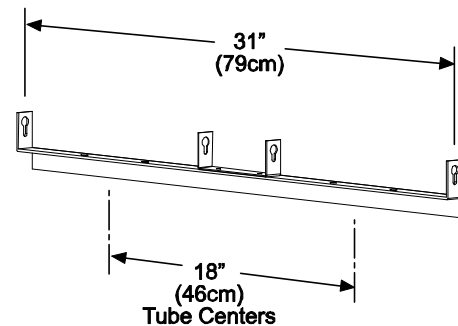

## 7) TYPICAL LAYOUTS

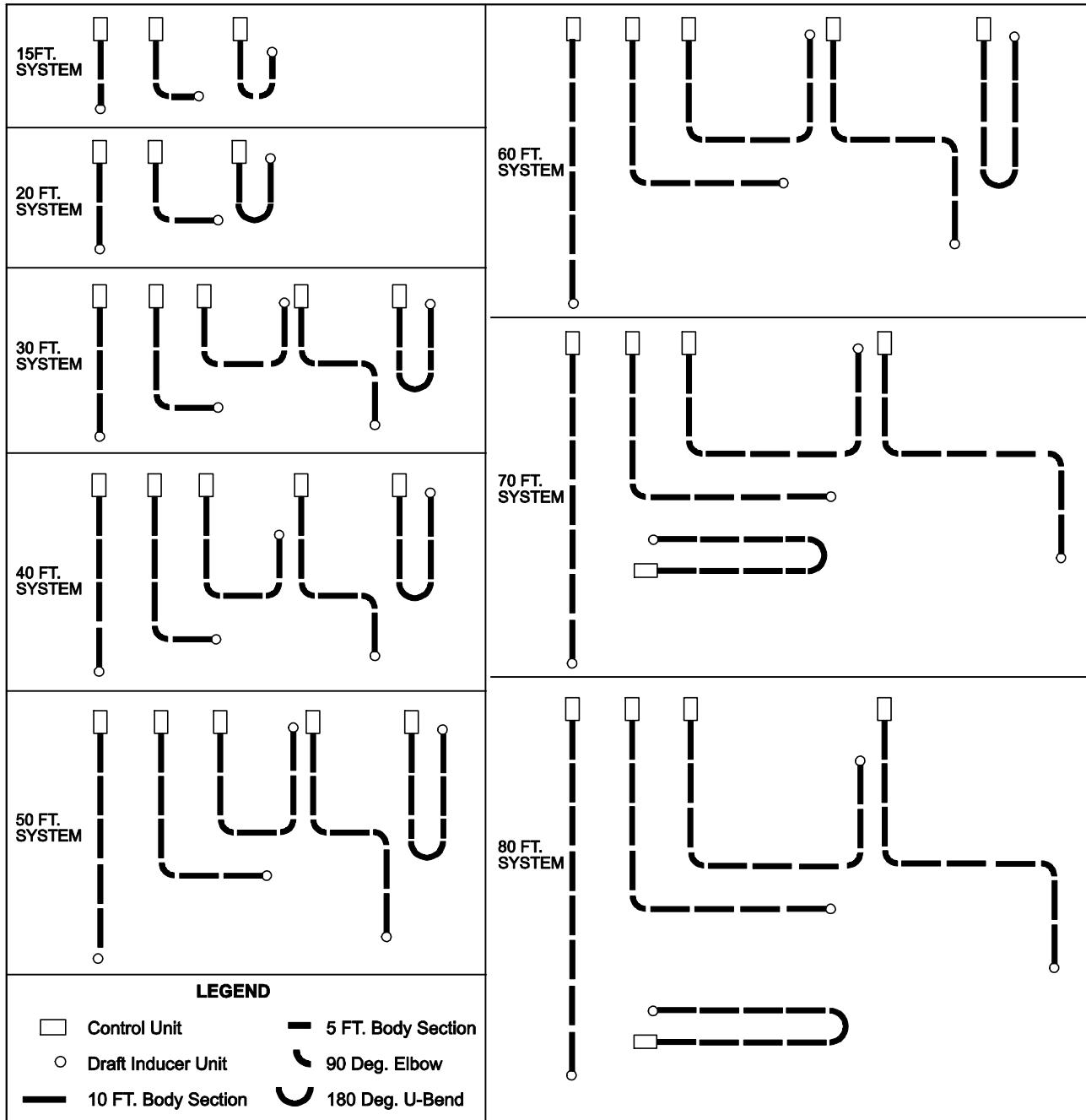

### NOTES:

1. In all configurations, the control unit must be connected directly to either a) the 24-hole flange of the 10 ft. aluminized steel start/end tube section (for ETS/ETU 40-200 models) or b) the 6-hole flange of the 10 ft. alumi-therm steel starting tube section (for ETS/ETU 225 and 250 models). **Failure to attach the control box to the 6-hole flange for ETS/ETU 225-250 as indicated above will void the manufacturer's warranty.**
2. Joining of two 90° elbows directly together to form a "Z" shape **IS NOT** permitted.
3. 5 Ft. Body Packages may be utilized on any of these heaters to yield heater lengths from 15 ft. to 80 ft.
4. Any configuration of components not shown in the illustrations may be used except as noted in 1 and 2 above.

MODEL	EMITTER LENGTH		MODEL	EMITTER LENGTH	
	Min.	Max.		Min.	Max.
ETS 40 (ETU 40)	15 Ft. (20 Ft.)	20 Ft. (20 Ft.)	ETS 130 (ETU 130)	30 Ft. (30 Ft.)	50 Ft. (50 Ft.)
ETS 50 (ETU 50)	15 Ft. (20 Ft.)	30 Ft. (30 Ft.)	ETS 140 (ETU 140)	40 Ft. (40 Ft.)	50 Ft. (50 Ft.)
ETS 60 (ETU 60)	20 Ft. (20 Ft.)	30 Ft. (30 Ft.)	ETS 150 (ETU 150)	40 Ft. (40 Ft.)	50 Ft. (50 Ft.)
ETS 75 (ETU 75)	20 Ft. (20 Ft.)	30 Ft. (30 Ft.)	ETS 160 (ETU 160)	40 Ft. (40 Ft.)	50 Ft. (50 Ft.)
ETS 80 (ETU 80)	30 Ft. (30 Ft.)	40 Ft. (40 Ft.)	ETS 175 (ETU 175)	40 Ft. (40 Ft.)	50 Ft. (50 Ft.)
ETS 90 (ETU 90)	30 Ft. (30 Ft.)	40 Ft. (40 Ft.)	ETS 180 (ETU 180)	50 Ft. (50 Ft.)	80 Ft. (80 Ft.)
ETS 100 (ETU 100)	30 Ft. (30 Ft.)	40 Ft. (40 Ft.)	ETS 200 (ETU 200)	50 Ft. (50 Ft.)	80 Ft. (80 Ft.)
ETS 110 (ETU 110)	30 Ft. (30 Ft.)	40 Ft. (40 Ft.)	ETS 225 (ETU 225)	50 Ft. (50 Ft.)	80 Ft. (80 Ft.)
ETS 120 (ETU 120)	30 Ft. (30 Ft.)	40 Ft. (40 Ft.)	ETS 250 (ETU 250)	50 Ft. (50 Ft.)	80 Ft. (80 Ft.)
ETS 125 (ETU 125)	30 Ft. (30 Ft.)	50 Ft. (50 Ft.)			

## 8) GAS CONNECTIONS

Certified connectors are recommended to be installed as shown, in one plane, and without sharp bends, kinks or twists. The gas take off from the drop line must be parallel to the burner gas inlet connection.

If the maximum supply pressure is less than 1/2 psig, a second stage regulator is not required.

### CORRECT POSITIONS

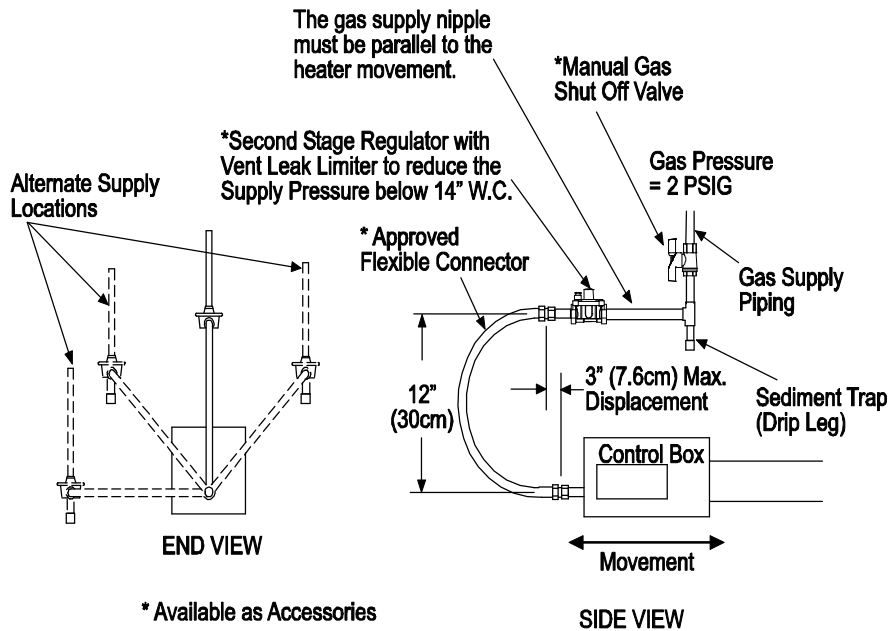

### INCORRECT POSITIONS

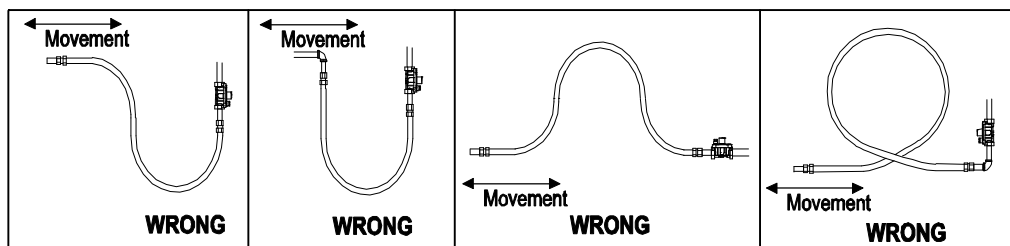

## 9) GAS PRESSURE TABLE

### SUPPLY PRESSURE

- The installer will provide a 1/8" N.P.T. tapped plug, accessible for test gauge connection immediately upstream of the gas supply connection to the heater.

GAS PRESSURE TABLE			
GAS TYPE	MANIFOLD PRESSURE	SUPPLY PRESSURE	
		Minimum*	Maximum
Natural Gas	3.5" W.C.	5" W.C. <sup>1</sup>	14" W.C.
Propane Gas	10.0" W.C.	11" W.C. <sup>2</sup>	14" W.C.

\* Minimum permissible gas supply pressure for purpose of input adjustment.

<sup>1</sup> 7" W.C. for ETS/U 150-250

<sup>2</sup> 12" W.C. for ETS/U 180-250

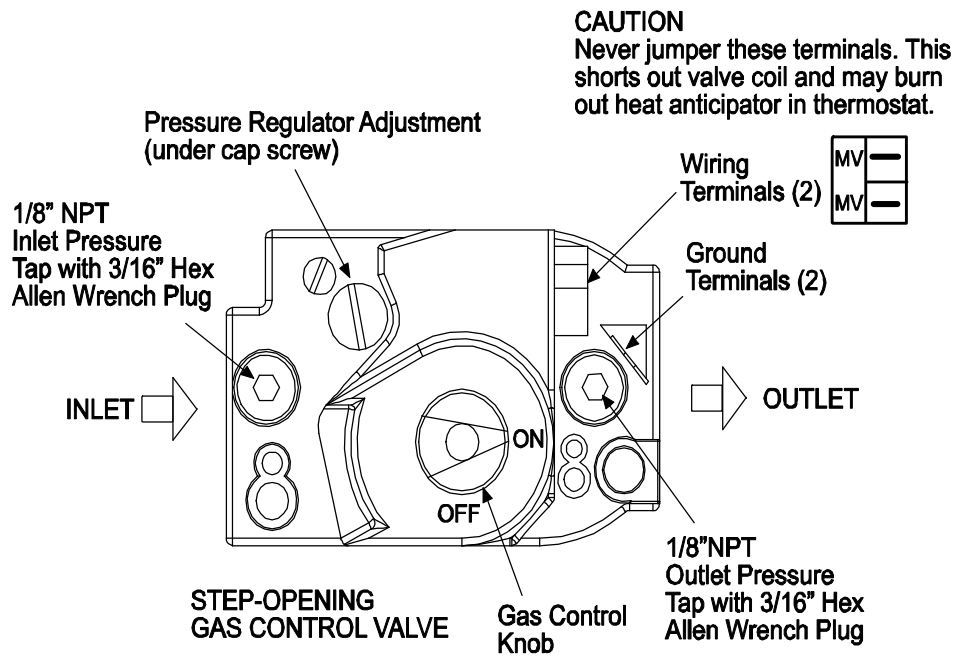

## 10) ELECTRICAL CONNECTIONS

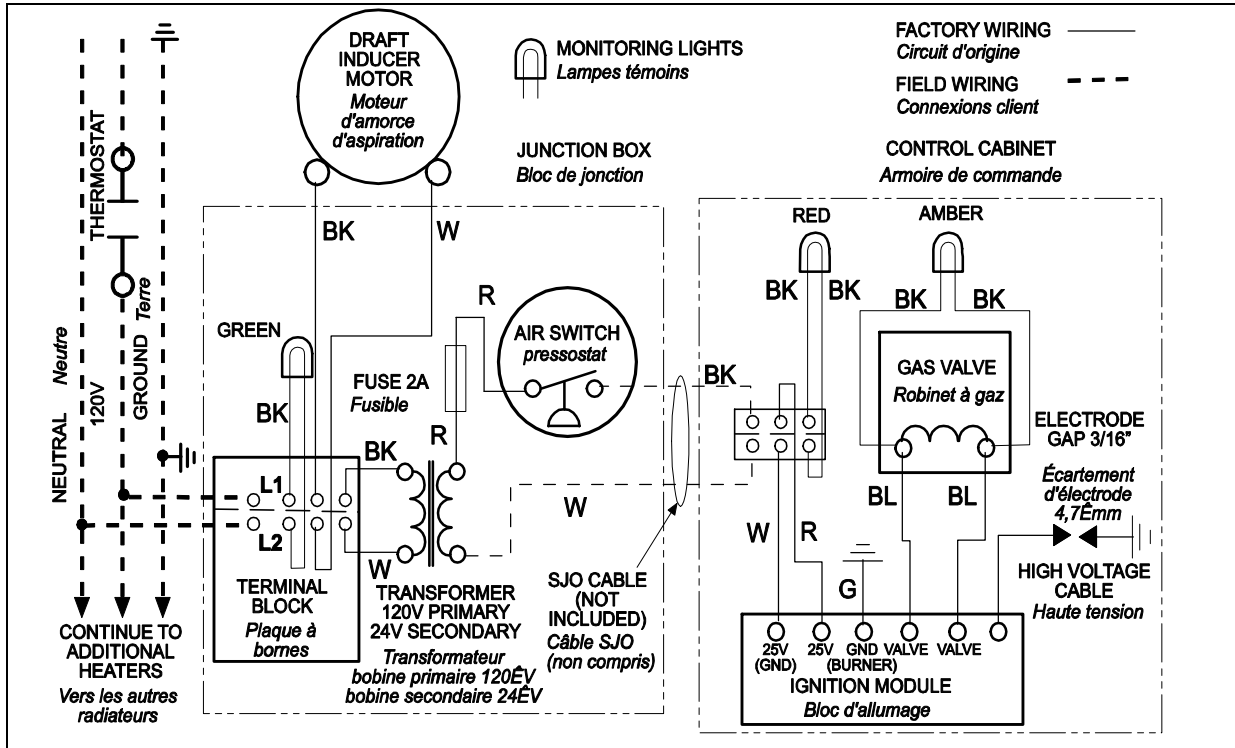

## 11) THERMOSTAT CONNECTIONS

### A. LINE VOLTAGE (120V) THERMOSTAT CONNECTIONS - SINGLE HEATER PER THERMOSTAT

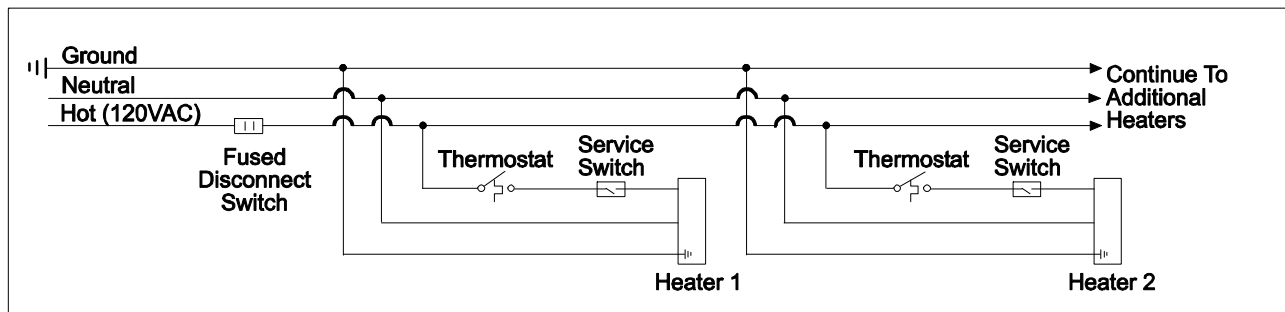

### B. LINE VOLTAGE (120V) THERMOSTAT CONNECTIONS - MULTIPLE HEATERS PER THERMOSTAT



## 12) VENTING

- A. BASIC FLUE VENTING** — Venting must comply with the latest edition of the National Fuel Gas Code (ANSI Z223.1-latest edition) or the authority having jurisdiction. Other venting references are in the equipment volume of the ASHRAE Handbook.

### **SINGLE HEATER VENTING (VERTICAL THROUGH THE ROOF)**

1. When venting the heater to outside of building through a roof, use single-wall metal pipe. This is to be constructed of galvanized sheet metal or other approved noncombustible corrosion-resistant material as allowed by state or local codes.
2. A vent passing through a combustible roof shall extend through an approved clearance roof thimble. Double-wall, Type B vent must be used for the portion of the vent system which passes through the combustible roof. An approved vent cap (Leslie "VersaCap"-Type B or equal) must be attached to end of the flue.
3. The maximum equivalent length of vent pipe should be carefully observed. A safety switch in the heater is designed to shut the heater off before excessive flue restriction causes bad combustion. Refer to the Vent Sizing Table for vent pipe diameter.
  - Minimum Equivalent Length = 5 ft. of pipe
  - Maximum Equivalent Length = 100 ft. of 4" pipe for 40-175 Models and 6" pipe for 180-250 ModelsUse the following correction factors to obtain the equivalent length:
  - Subtract 15 ft. if the run is horizontal. (maximum horizontal length for 4" pipe is 25 ft.)
  - Subtract 10 ft. for an approved vent cap.
  - Subtract 10 ft. for each elbow beyond 15 ft. from the heater.
  - Subtract 15 ft. for each elbow within 15 ft. of the heater.
4. Joints between sections of piping shall be fastened by sheet metal screws or other approved means and should be sealed to prevent leakage of flue gas into building. Aluminum or Teflon tape suitable for 550°F (3M Company tapes 433 or 363) or silicone sealant is recommended.
5. Avoid locating elbows in the first 5' of vent pipe whenever possible. Limit to (2) 90° elbows. When vent pipe is in a horizontal run, it must have 1/4 inch per foot rise.
6. All portions of the vent pipe shall be supported to prevent from sagging (6' spacing is recommended).
7. When the vent pipe passes through areas where the ambient temperature is likely to induce condensation of the flue gases, the vent pipe should be insulated and a condensation drain should be provided.
8. Minimum clearance for single-wall flue pipe to combustible material shall be 6 inches. This may be reduced when the combustible material is protected as specified in the National Fuel Gas Code or the authority having jurisdiction.
9. Single-wall metal pipe shall not originate in any unoccupied attic or concealed space and shall not pass through any attic, inside wall or concealed space, or through any floor. For the installation of a single-wall metal pipe through an exterior combustible wall, refer to latest edition of the National Fuel Gas Code or the authority having jurisdiction.
10. A venting system shall terminate at least 3 ft. above any forced air inlet located within 10 ft.

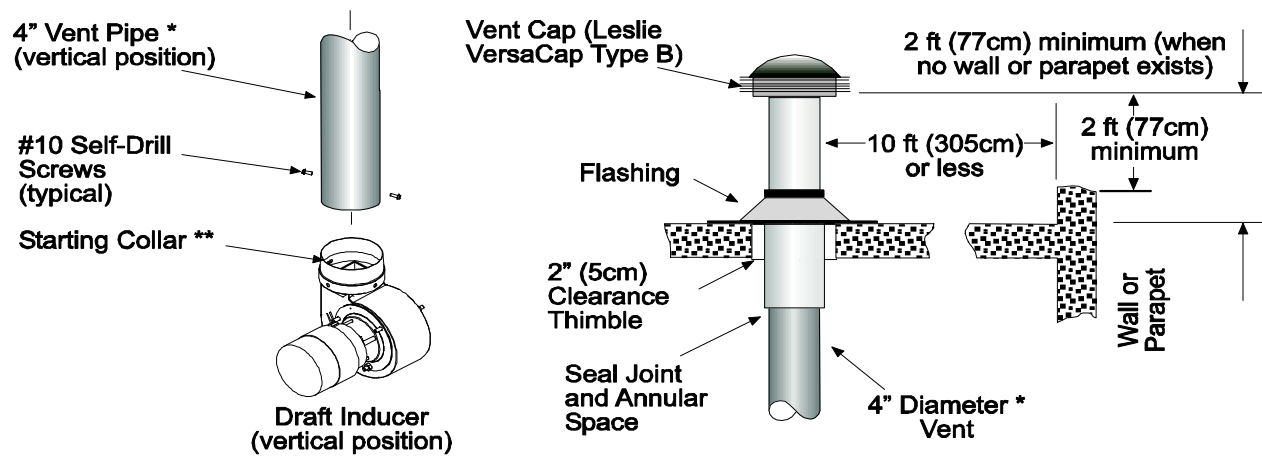

\* 6" for LTS/U 180-250 Models

\*\* 4"x6" Adaptor included for LTS/U 180-250 Models

Note: Junction Box is not shown.

### **SINGLE HEATER VENTING (HORIZONTAL THROUGH SIDEWALL)**

When venting the heater horizontally through a combustible outside sidewall, the same requirements listed previously for venting **Vertical Through The Roof** apply except as follows:

1. A vent passing through a combustible wall must pass through an approved clearance thimble (Air-Jet #4VT or Ameri-Vent #4EWT or other thimbles) that are listed by a nationally recognized testing agency. Double-wall Type B vent must be used for the portion of the vent system which passes through the combustible sidewall.
2. An approved vent cap (Bredert-Type L or equal) must be attached to the end of the vent pipe.
  - 4" vent – 25 ft. maximum with one 90° elbow and vent cap for 40-175 Models
  - 6" vent – 75 ft. maximum with maximum two 90° elbows and vent cap for all Models

If other horizontal vent configurations are required, consult the manufacturer.

**NOTE:** To minimize problems associated with condensation in long horizontal runs, vent pipe can be insulated.

3. When venting through a sidewall, the horizontal vent pipe shall rise not less than 1/4 inch per foot from the start of the vent system to the vent terminal. All portions of the vent pipe shall be supported to prevent sagging. (6' spacing is recommended)
4. A minimum clearance of 6 inches must be maintained between the outside wall and vent cap.
5. The horizontal venting system shall not terminate:
  - Less than 4 ft. (1.2m) below, 4 ft. (1.2m) horizontally from or 1 ft. (30cm) above any door, operable window or gravity air inlet into any building. The bottom of the vent terminal shall be located at least 7 ft. (2.1m) above grade or above snow accumulation level as determined by local codes.
  - Less than 3 ft. (0.9m) from a combustion air inlet.
  - Less than 3 ft. (0.9m) from any other building opening or any gas service regulator.
  - Less than 7 ft. (2.1m) above public walkways.
  - Directly over areas where condensate or vapor could create a nuisance or hazard or be harmful to the operation of gas utility meters, regulators, relief valves, or other equipment. Building materials should be protected from flue gases and condensate.
  - Less than 12" (0.30m) when directly below a combustible overhang.
6. In regions of the country where prevailing winds are consistently higher than 40 mph, it may be necessary to terminate the vent system above the roof level.

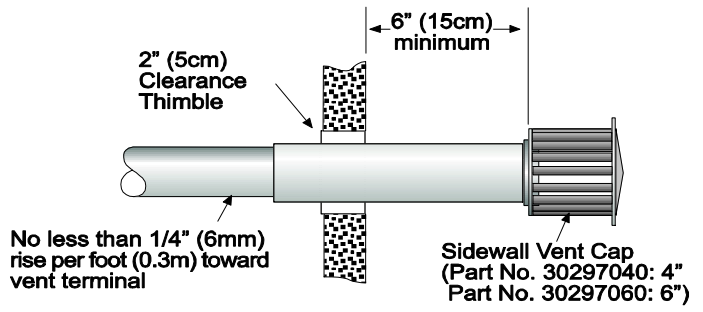
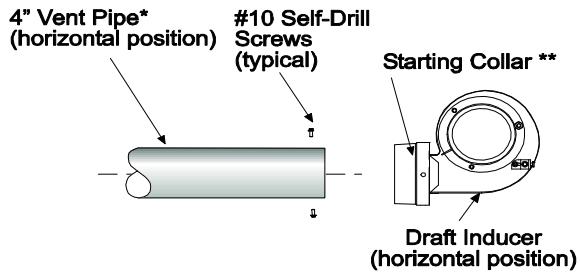

\* 6" for ETS/U 180-250 Models  
 \*\* 4"x6" Adaptor included for ETS/U 180-250 Models

Note: Junction Box is not shown.

## **MULTIPLE HEATER VENTING (CONNECTIONS INTO A COMMON VENT OR MANIFOLD)**

Requirements for venting of multiple heaters are the same as described for **SINGLE HEATER VENTING** except as follows:

1. The common vent size and total vent height is normally determined by the number of heaters per common vent, length of horizontal connector runs, and connector rise. Connector lengths should be as short as possible and have a minimum 1/4 inch per foot rise. Without regard to connector rise and total vent height due to many possible venting configurations, the following should be observed:
  - Common vent pipe & vent connector diameter should be no less than that shown in the following Vent Sizing Table.
  - The connector length should be no more than 75% of the vertical portion of vent above the connector.
  - Where possible, use a Y-connector to the common vent.
2. Material for connectors should be constructed of galvanized sheet metal or other approved noncombustible corrosion resistant material as allowed by state or local codes. All common vent pipe should be double-wall, Type B vent.
3. Avoid unnecessary bends. Limit to two (2) 90° elbows.
4. The entire length of vent connector shall be readily accessible for inspection, cleaning and replacement.
5. Groups of heaters with a common vent must be controlled by a common thermostat.

### **Multiple Heater Vertical Venting Arrangement**

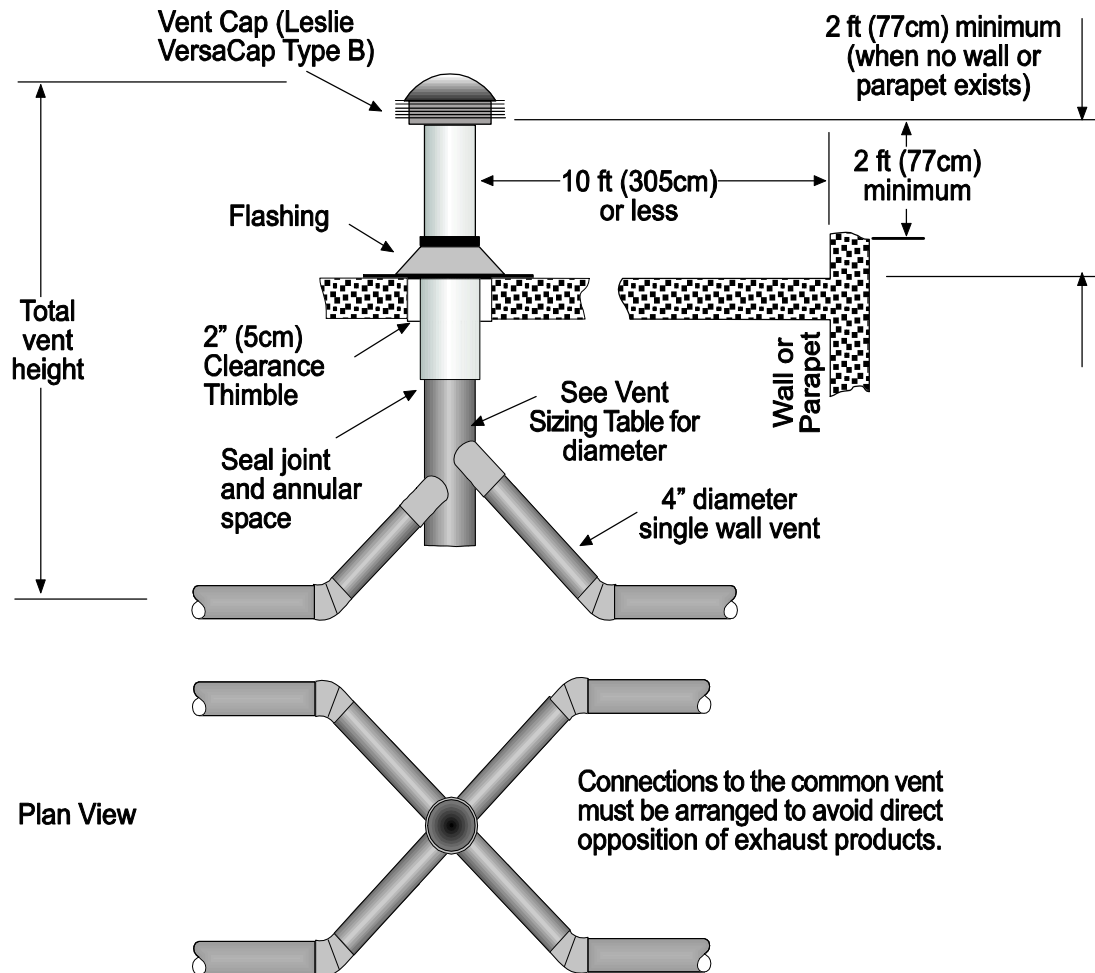

**Multiple Heater Horizontal Venting Arrangement**

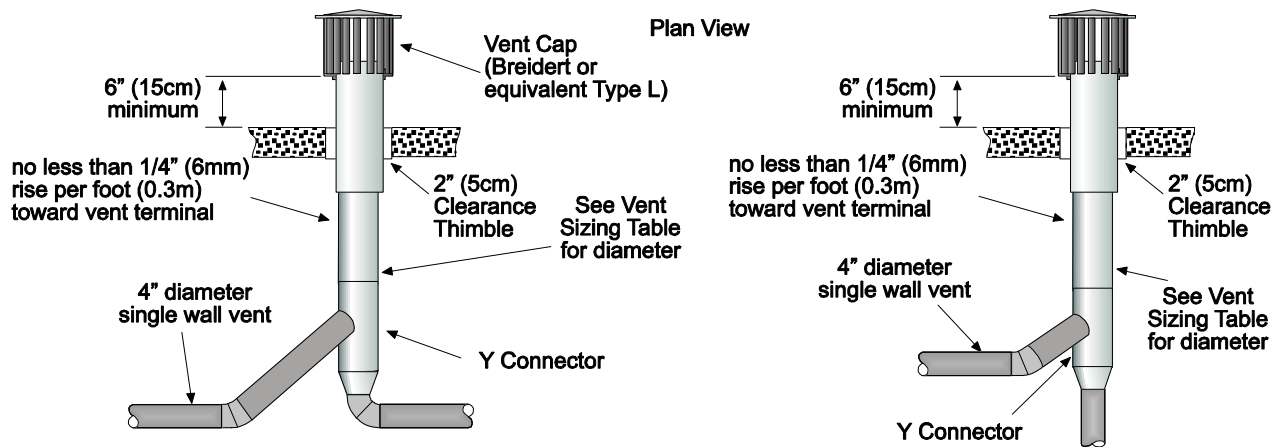

**Multiple Heater Venting (Connections into a Manifold)**

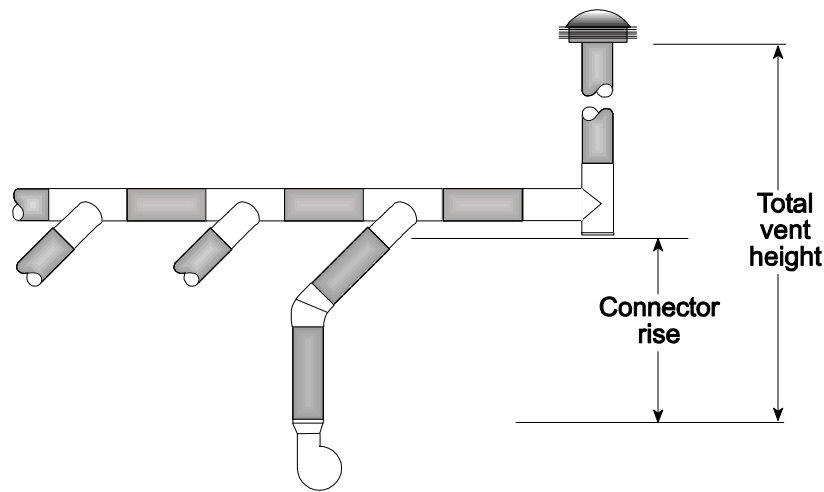

<b>VENT SIZING TABLE — Multiple Heater Venting</b>					
	<b>Number of Heaters</b>				
	<b>1</b>	<b>2</b>	<b>3</b>	<b>4</b>	<b>5</b>
ETS/U40-50	4"	4"	5"	5"	6"
ETS/U60-75	4"	5"	6"	6"	7"
ETS/U80-100	4"	6"	6"	7"	8"
ETS/U110-130	4"	6"	7"	8"	9"
ETS/U140-175	4"	6"	8"	9"	10"
ETS/U180-200	6"	8"	9"	10"	11"
ETS/U225-250	6"	9"	10"	11"	12"

**COMMON VENT DIAMETER**  
(If a size is not available use the next larger size.)

THE ABOVE ILLUSTRATIONS AND TABLE OF VENT SIZES FOR COMMON VENTING OF MULTIPLE HEATERS ARE IN ACCORDANCE WITH THE NATIONAL FUEL GAS CODE ANSI Z223.1-LATEST EDITION, NFPA 54-LATEST EDITION, EQUIPMENT VOLUME OF 1988 ASHRAE HANDBOOK, CURRENT CAN/CGA-B149.1/2-M86 INSTALLATION CODE, AND AGA PUBLICATION NO. 10M5.85 2.5-2 ON FUNDAMENTALS OF GAS APPLIANCE VENTING AND VENTILATION-REVISED BUT ARE NOT A PART OF THE CSA CERTIFICATION.

**B. INDIRECT VENTING (UNVENTED HEATERS)** — This heater requires ventilation in the building to dilute the products of combustion and provide fresh air for efficient combustion. Where unvented heaters are used, gravity or mechanical means shall be provided to supply and exhaust at least 4 CFM per 1,000 Btu/hr input of installed heaters. Exhaust vents must be located at the highest point above and in the vicinity of the heaters, and the inlet vents must be located below the level of the heaters. An exhaust hood (Part #42924000) must be placed on the outlet collar of the draft inducer or on the existing 4" starting collar when used unvented and **must be mounted only in an upright position and directed towards the reflector body as shown.**

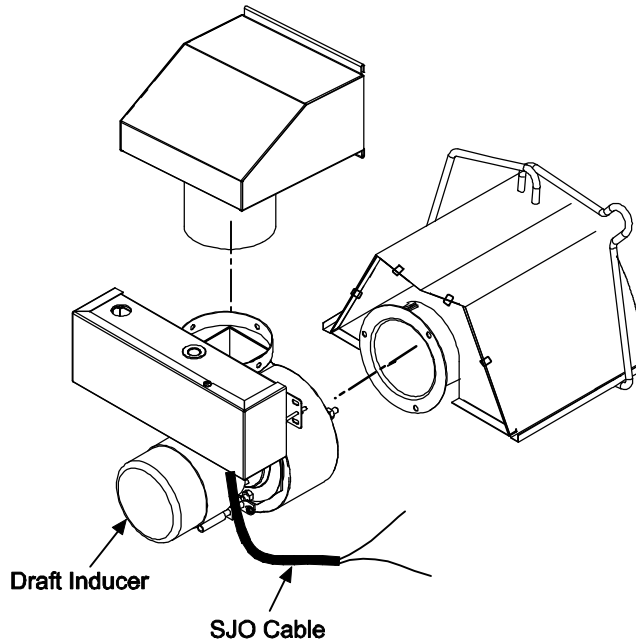

### 13) AIR FOR COMBUSTION

If indoor combustion air is to be supplied for a tightly enclosed area, one square inch of free area opening shall be provided below the heater for each 1,000 Btu/hr per hour of heater input. When outside air is used, the opening below the heater shall be one square inch of free area for each 4,000 Btu/hr of heater input. In contaminated atmospheres or high humidity areas, optional outside air for combustion is recommended. Adequate clearances around the perforated fresh air plate must be maintained at all times. In larger open areas of buildings, infiltration normally is adequate to provide air for combustion.

### 14) DIRECT OUTSIDE AIR FOR COMBUSTION

Outside combustion air should be supplied directly to the heater when the building is subject to negative pressure, or when contaminants or high humidity are present in the building air. These contaminants include paints, solvents, corrosive vapors or any other foreign particles that may cause damage to the heater or result in poor combustion.

Outside combustion air can be brought directly to the heater by a 6" diameter duct less than 50 ft. long or equivalent. This is attached to the 6" diameter starting collar. The starting collar is fitted to the top of the control box cabinet **after first removing and discarding the perforated cover.** An approved vent cap must be placed directly on the end of the outside combustion air inlet pipe. The combustion air inlet should be not less than 3 ft. (0.9m), either vertically or horizontally, from the flue vent termination. The air intake terminal must be located not less than 1 ft. (30cm) above grade. It is good installation practice to supply combustion air from the same pressure zone as the vent outlet. Avoid bringing combustion air to the heater from an attic space. There is no guarantee that adequate combustion air will be supplied.

If the heater is installed less than 2 ft. from the ceiling, a flexible transition section (e.g., flexible aluminum duct) must be provided to allow for expansion/contraction of straight tube heaters (ETS Series).

In colder climates, where necessary, insulate the outside combustion air duct. Avoid locating the outside combustion air duct directly above the control box. Provide a capped cleanout T as necessary. In high humidity applications, the control box should be sealed with silicone sealer.

In **multiple heater applications**, the combustion air intake may be ducted individually or common ducted in the same configuration as shown for venting in Section 12. For combustion air intake duct sizing, please refer to the **Vent Sizing Table** and use the diameter indicated, based on the number of heaters per duct.

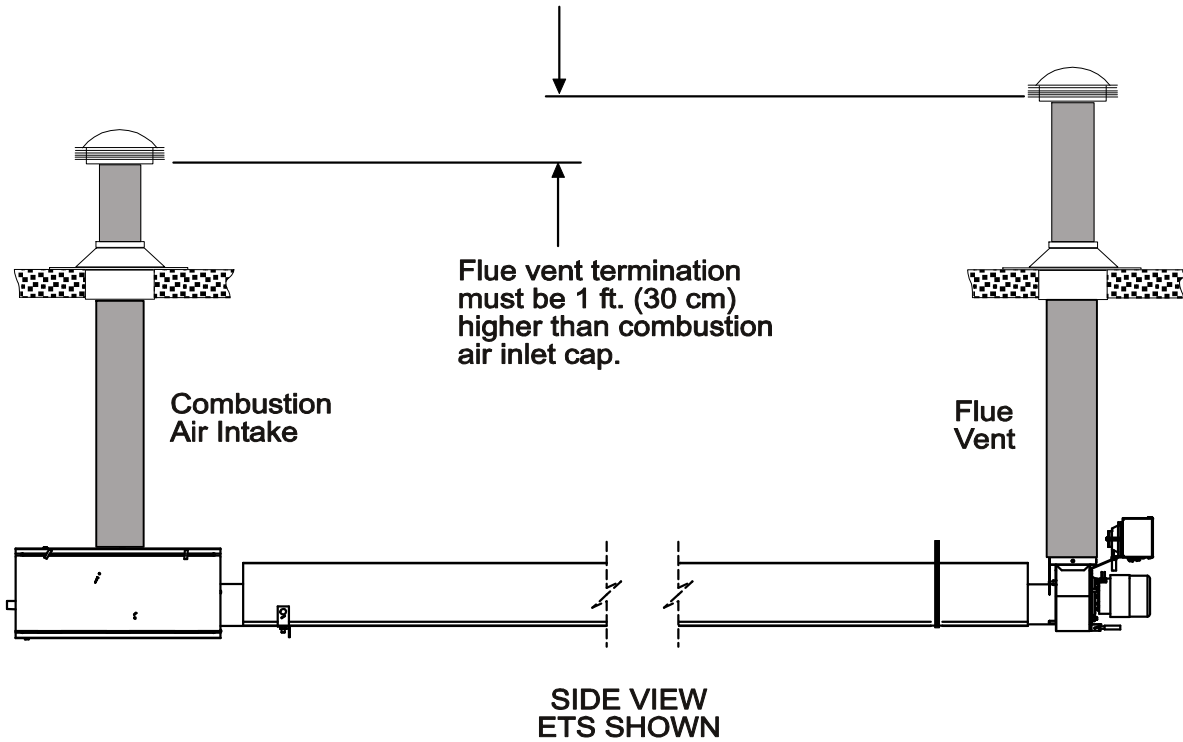

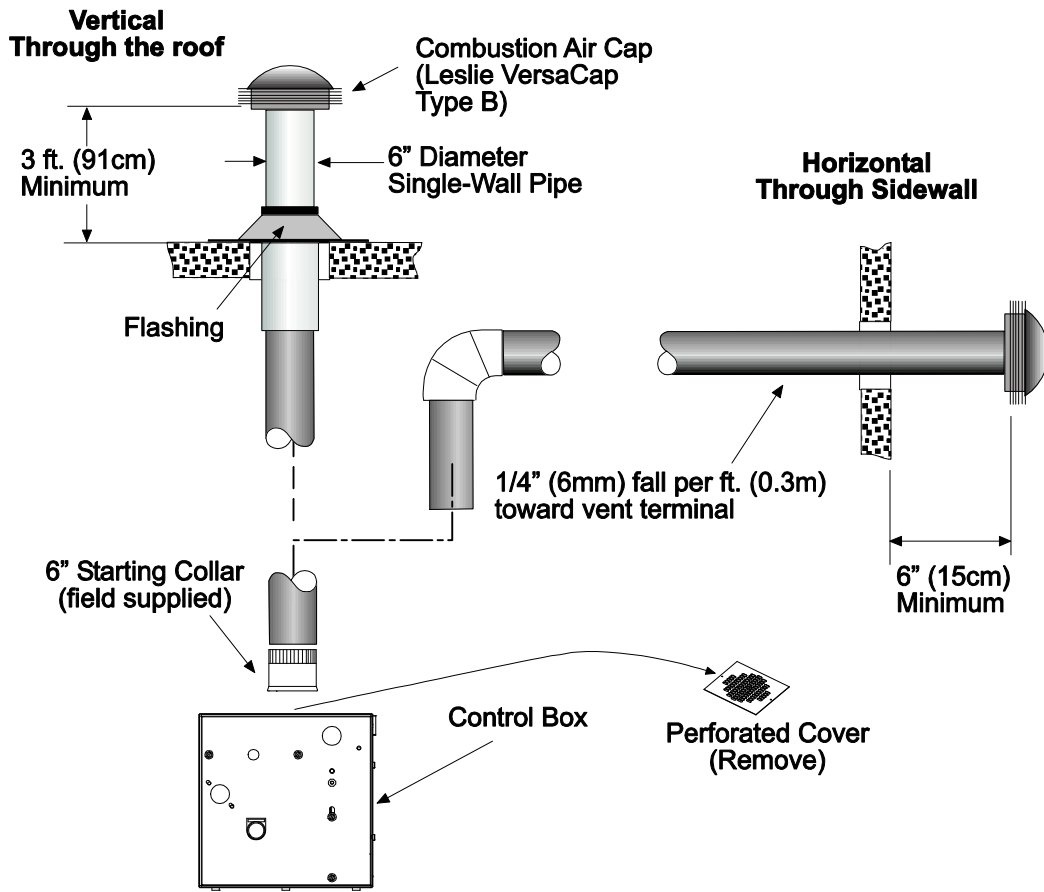

# 15) SEQUENCE OF OPERATION

The chart below shows the sequence of operation for the normal operating cycle.

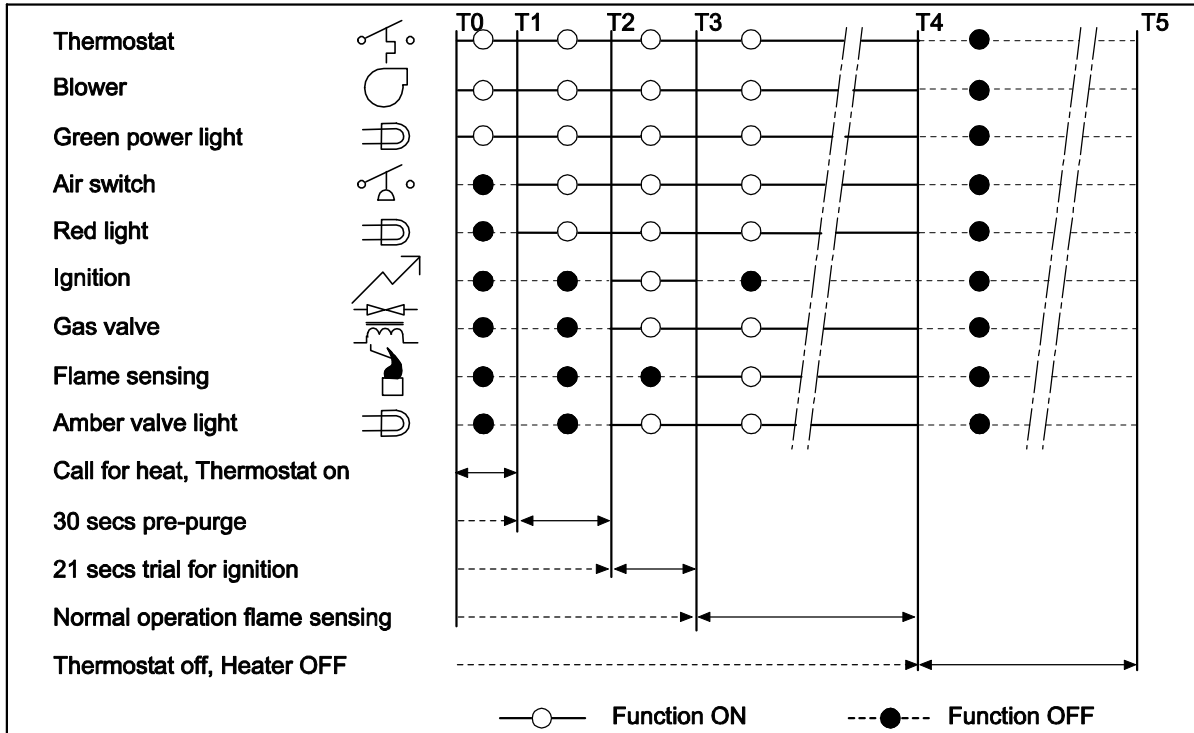

If the flame is not sensed during sequence T3 then the burner will automatically begin ignition sequence T2. If the flame is not re-established the heater will go to lockout.

## 16) LIMITED WARRANTY

**LIMITED WARRANTY:** Gas-Fired Products, Inc., the manufacturer, warrants to the original owner of any Space-Ray infrared gas heater that said heater will be free from defects in material or workmanship under normal use and service. The heater(s) shall be installed, used and maintained strictly in accordance with the manufacturer's instructions. The manufacturer's sole obligation under this warranty shall be limited to furnishing replacement parts, F.O.B. Charlotte, NC, for 12 months from the date of installation, or 18 months from the date of shipment by the manufacturer, whichever period shall expire first. Labor charges for removal of defective parts and the installation of the replacement parts are not included. This warranty applies only within the USA and Canada.

**WARNING:** Manufacturer's warranty shall not apply: (a) to damage to the heater when used in an atmosphere containing halogenated hydrocarbons or other corrosive chemicals. Some compounds in the air can be ingested into the equipment and can cause an accelerated rate of corrosion of some of the parts of the heating components. The use of such chemical compounds in or near the operating environment of the heater should be avoided where a longer heater life is desirable; (b) to any heater or components which have been repaired or replaced with other than factory parts, modified in any way, misused or damaged, or which have been used contrary to the manufacturer's written instructions. Replacement parts are available through Space-Ray representatives or their distributors.

**LIMITATION OF WARRANTY:** THERE ARE NO WARRANTIES, EXPRESS OR IMPLIED, WHICH EXTEND BEYOND THE DESCRIPTION ON THE FACE HEREOF. WITHOUT LIMITING THE FOREGOING, THE MANUFACTURER EXPRESSLY EXCLUDES ANY AND ALL IMPLIED WARRANTIES, INCLUDING BUT NOT LIMITED TO ANY IMPLIED WARRANTY OF FITNESS FOR A PARTICULAR PURPOSE AND ANY IMPLIED WARRANTY OF MERCHANTABILITY FOR ITS PRODUCTS.

If any provision of this warranty is found to be void, unenforceable or unconscionable, then the same is hereby severed and the remainder of this warranty is hereby saved and shall remain in force.

**EXCLUSIVE REMEDY:** The sole and exclusive remedy under this warranty is the replacement of the defective parts or heaters as hereinabove specified. THE MANUFACTURER DOES HEREBY EXPRESSLY EXCLUDE ANY AND ALL LIABILITY FOR INCIDENTAL AND CONSEQUENTIAL DAMAGES UNDER THIS OR ANY OTHER WARRANTY. Without intending to limit the aforesaid exclusion, THE MANUFACTURER DOES HEREBY EXCLUDE ANY LIABILITY UNDER THIS OR ANY OTHER WARRANTY FOR INJURIES AND COMMERCIAL LOSSES TO PROPERTY THAT RESULT FROM THE OPERATION, PROPER OR IMPROPER, OF ITS PRODUCTS.

**ADDITIONAL WARRANTY ON HEAT EMITTING SURFACE AND BURNER:** Manufacturer warrants to the original owner of any CSA design certified heater that, if installed, used and maintained strictly in accordance with the printed instructions received with the heater, the manufacturer will at any time during the below listed time periods, furnish at no cost to the original owner, replacement emitters or burners which have become inoperative by reason of any defect in our workmanship, materials or construction. The manufacturer's obligation under this warranty shall be limited to furnishing replacements under the following time periods from the date of installation:

	<u>Emitter</u>	<u>Burner</u>
ETS, ETU Series:	3 Years	10 Years

The manufacturer will not be responsible for labor charges incurred for removal or installation of emitters. Any transportation charges involved in the return or repair are excluded.

**ADDITIONAL TERMS:** Manufacturer assumes no liability for delay in performing its obligations under the aforesaid warranty. Manufacturer assumes no liability for failure in performing its obligations thereunder if failure results directly or indirectly from any cause beyond its control, including but not limited to acts of God, acts of Government, floods, fires, shortages of materials, strikes and other labor difficulties or delays or failures of transportation facilities.

This is a Non-Residential product (excluding the CB Series which is certified for residential and non-residential use). Installation and service shall be by a Licensed Contractor and in accordance with National and Local Codes.

When presenting warranty claims, proof of date of purchase must be submitted.

No Representative is authorized to assume for the manufacturer any liability except as set forth above.

**SPACE-RAY®**

A Division of Gas-Fired Products, Inc.

Post Office Box 36485 (28236) • 305 Doggett Street (28203) • Charlotte, North Carolina

