



SUBMITTAL DATA

INFRARED RADIANT TUBE HEATER

LTU 40-250 SERIES
(CHECK ONE)

N-NATURAL GAS
(CHECK ONE)

5-SINGLE STAGE
(CHECK ONE)

LTU 40-200 SERIES

L-PROPANE GAS

7-TWO STAGE

PROJECT:

NAME:

DATE:

ADDRESS:

ARCHITECT/ENGINEER:

NAME:

ADDRESS:

CONTRACTOR:

NAME:

ADDRESS:

SUBMITTED BY:

EQUIPMENT USED:

ACCESSORIES:

- Chain Mounting Kit _____
- Thermostat _____
- Gas Pressure Regulator _____
- Gas Shut-Off Valve _____
- Side Reflector _____
- Corner Reflector _____

- Vent Cap _____
- Combustion Air Cap _____
- 90° Elbow _____
- Other _____
- Other _____
- Other _____

1) GENERAL INFORMATION

This heater complies with ANSI Z83.6 (current standard) and CAN 1-2.16. Copies of the National Fuel Gas Code (ANSI Z223.1-latest edition) are available from the CSA at 8501 East Pleasant Valley Road, Cleveland, OH 44131 or 55 Scarsdale Road, Don Mills, Ontario M3B 2R3. All NFPA codes are available from the National Fire Protection Association, Batterymarch Park, Quincy, MA 02269.

This heater is a self-contained infrared radiant tube heater for use in locations where flammable gases or vapors are not generally present (as defined by OSHA acceptable limits) and is intended for the heating of nonresidential spaces.

INSTALLATION REQUIREMENTS

Installation of this heater must be in accordance with all applicable codes shown in the instructions and/or the local codes and authorities having jurisdiction. In Canada, the installation must conform to current CAN/CGA-B149.1/2 Installation Code in the absence of local codes. Heaters shall be installed by a licensed contractor or licensed installer. Clearances to combustibles as outlined in this manual should always be observed. In areas used for storage of combustible materials where they may be stacked below the heater, NFPA54 requires that the installer must post signs that will "specify the maximum permissible stacking height to maintain the required clearances from the heater to combustibles."

Every heater shall be located with respect to building construction and other equipment so as to permit access to the heater. Each installer shall use quality installation practices when locating the heater and must give consideration to clearances to combustible materials, vehicles parked below, lights, overhead doors, storage areas with stacked materials, sprinkler heads, gas and electrical lines, and any other possible obstructions or hazards. Consideration also must be given to service accessibility.

The heater, when installed in aircraft hangars and public garages, must be installed in accordance with ANSI/NFPA 409-latest edition (Standard for Aircraft Hangars), ANSI/NFPA 88a-latest edition (Standard for Parking Structures), and ANSI/NFPA 88b-latest edition (Standard for Repair Garages) with the following clearances:

- a. At least 10 feet above the upper surfaces of wings or engine enclosures of the highest aircraft that may be housed in the hangar and at least 8 feet above the floor in shops, offices, and other sections of hangars communicating with aircraft storage or service areas.
- b. At least 8 feet above the floor in public garages. **▲WARNING:** Minimum clearances marked on the heater must be maintained from vehicles parked below the heater.

(FOR CANADA ONLY)

- a. Installation of this appliance is to be in accordance with latest edition of CAN 1-B149.1 (Installation Code for Natural Gas Burning Appliances and Equipment), and/or CAN B149.2 (Installation Code for Propane Gas Burning Appliances and Equipment).
- b. For installation in public garages or aircraft hangars, minimum clearances from the bottom of the infrared heater to the upper surface of the highest aircraft or vehicle shall be 50 percent greater than the certified minimum clearance, but the clearance shall not be less than 8 feet.

This heater is for Indoor Installation and Covered Patio Installation only and can be used in either Vented or Unvented mode. The term Unvented actually means Indirect Vented. While the products of combustion are expelled into the building, national codes require ventilation in the building to dilute these products of combustion. This ventilation may be provided by gravity or mechanical means.

This heater is not an explosion proof heater. Where the possibility of exposure to volatile and low flash point materials exists, it could result in property damage or death. This heater must not be installed in a spray booth where the heater can operate during the spraying process. Consult your local fire marshal or insurance company.

▲WARNING: Certain materials or objects, when stored under the heater, will be subjected to radiant heat and could be seriously damaged. Observe the Minimum Clearances to Combustibles listed in the manual and on the heater at all times.

2) MINIMUM CLEARANCES TO COMBUSTIBLES

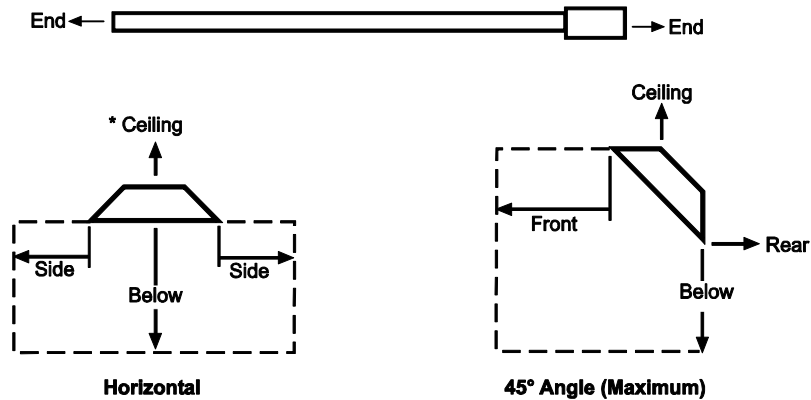

MINIMUM CLEARANCES TO COMBUSTIBLES						
Model No.	Mounted Horizontally				Angle Mounted at 45°	
	Sides	Ceiling*	Below	Ends	45° Front	45° Rear
LTU 40, 50	27"	6"	40"	30"	48"	12"
LTU 60, 75	27"	6"	60"	30"	48"	12"
LTU 80, 90	52"	6"	84"	30"	52"	12"
LTU 100	66"	6"	88" **	40"	66"	20"
LTU 110, 120, 125, 130	66"	6"	101" **	40"	66"	20"
LTU 140, 150, 160, 175	84"	6"	106" **	48"	84"	24"
LTU 180, 200, 225, 250	84"	18"	132" **	48"	84"	24"

* When used indirect vented, minimum clearance for CEILING must be: 12" for LTU 40-75 and 18" for LTU 80-250. If optional corner and U-bend reflectors are not used, the clearance must be 18".

** Maximum clearance below reduces to 72" once you are 20 ft. downstream from the control box.

▲ WARNING: Certain materials or objects, when stored under the heater, will be subjected to radiant heat and could be seriously damaged. Observe the Minimum Clearances to Combustibles listed in the manual and on the heater at all times.

NOTE:

1. The clearances specified above must be maintained to combustibles and other materials that may be damaged by temperatures 90°F above ambient temperature. Clearances to combustibles are posted on the control box. In areas used for storage of combustible materials where they may be stacked below the heater, NFPA54 requires that the installer must post signs that will "specify the maximum permissible stacking height to maintain the required clearances from the heater to combustibles." Space-Ray recommends posting these signs adjacent to the heater thermostat or other suitable location that will provide enhanced visibility.

2. The stated clearance to combustibles represents a surface temperature of 90 °F (32 °C) above room temperature. Building materials with a low heat tolerance (such as plastics, vinyl siding, canvas, tri-ply, etc.) may be subject to degradation at lower temperatures. It is the installer's responsibility to assure that adjacent materials are protected from degradation.

3) SPECIFICATIONS

Model No.	Input, Btu/hr		Flue Restrictor Plate I.D. & Part #		Orifice Size				Minimum * Mounting Height	
	High	Low			Natural Gas		Propane Gas		@ Horizontal	@ 45° Angle
LTU 40	40,000	25,000	1"	#42741040	#31	(0.120)	#49	(0.073)	10 ft.	9 ft.
LTU 50	50,000	31,500	1-1/8"	#42741030	3.3mm	(0.130)	#46	(0.081)	11 ft.	10 ft.
LTU 60	60,000	38,000	1-7/32"	#42741020	#27	(0.144)	#43	(0.089)	12 ft.	11 ft.
LTU 75	75,000	50,000	1-7/16"	#42741010	#20	(0.161)	#39	(0.099)	13 ft.	12 ft.
LTU 80	80,000	50,500	1-1/2"	#42741050	#19	(0.166)	#38	(0.102)	13 ft.	12 ft.
LTU 90	90,000	57,000	1-1/2"	#42741050	#16	(0.177)	#36	(0.106)	13 ft.	12 ft.
LTU 100	100,000	63,000	1-5/8"	#42741060	#14	(0.182)	#33	(0.113)	13 ft.	12 ft.
LTU 110	110,000	69,500	1-3/4"	#42741070	#10	(0.194)	#31	(0.120)	14 ft.	13 ft.
LTU 120	120,000	76,000	1-3/4"	#42741070	13/64	(0.203)	1/8	(0.125)	14 ft.	13 ft.
LTU 125	125,000	80,000	1-7/8"	#42741080	#5	(0.206)	#30	(0.129)	14 ft.	13 ft.
LTU 130	130,000	82,000	1-7/8"	#42741080	#4	(0.209)	3.3mm	(0.130)	14 ft.	13 ft.
LTU 140	140,000	88,500	2-1/32"	#42741090	5.5mm	(0.216)	#29	(0.136)	15 ft.	14 ft.
LTU 150	150,000	95,000	2-1/32"	#42741090	5.7mm	(0.224)	#28	(0.140)	15 ft.	14 ft.
LTU 160	160,000	100,000	2-1/4"	#42741100	5.8mm	(0.228)	#27	(0.144)	15 ft.	14 ft.
LTU 175	175,000	110,000	2-1/4"	#42741100	"C"	(0.242)	3.8mm	(0.150)	15 ft.	14 ft.
LTU 180	180,000	114,000	2-1/4"	#42741100	"C"	(0.242)	#24	(0.152)	18 ft.	17 ft.
LTU 200	200,000	125,000	2-3/8"	#42741130	"F"	(0.257)	#21	(0.159)	18 ft.	17 ft.
LTU 225	225,000	N/A	2-1/2"	#42741140	6.9mm	(0.272)	#18	(0.170)	20 ft.	19 ft.
LTU 250	250,000	N/A	2-3/4"	#42741150	"K"	(0.281)	4.5mm	(0.177)	20 ft.	19 ft.

*MOUNT HEATERS AS HIGH AS POSSIBLE. Minimums are shown as a guideline for human comfort and uniform energy distribution for complete building heating applications. Consult your Space-Ray representative for the particulars of your installation requirements.

CONTROL OPTIONS

Control Suffix	Type of gas	Description
N5	Natural	Single Stage Gas Valve - Single Stage Input
L5	Propane	Single Stage Gas Valve - Single Stage Input
N7	Natural	Two Stage Gas Valve - Modulating Input - High/Low Fire
L7	Propane	Two Stage Gas Valve - Modulating Input - High/Low Fire

Type Gas	Gas Pipe Connection ¹	Tube Diameter	Flue Connection ²	Fresh Air Connection	Electrical Supply	Current Rating
Natural or Propane	1/2" MPT (Male)	4"	4" Round	6" Round	120 Volt, 60Hz, 1 Phase	2.6 Amp

¹ LTU 225 and 250 require a minimum 3/4" nominal ID flexible gas connection.

² LTU 180-250 require 6" round. See Section 13 for common vent sizes and limitations.

Fuse Rating:		Ignition System (direct spark):
In-line: 2 Amp 250V (for 24V Circuit)	Spark Module: 3 Amp 250V (for 24V Circuit)	30 second pre-purge period

4) DIMENSIONS - LTU40-75 SERIES

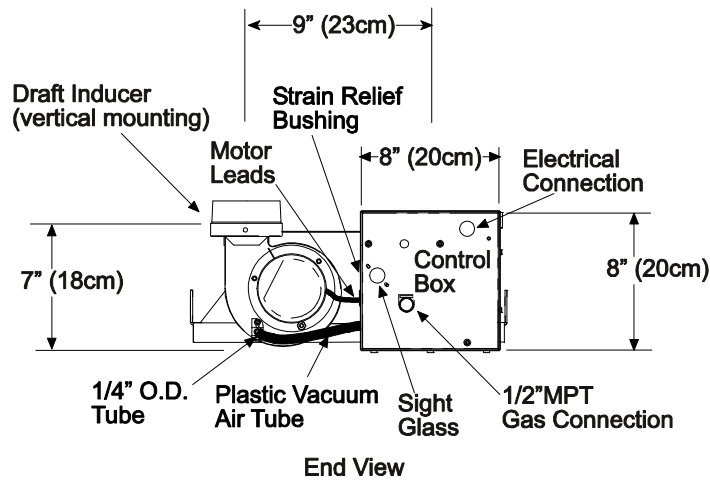
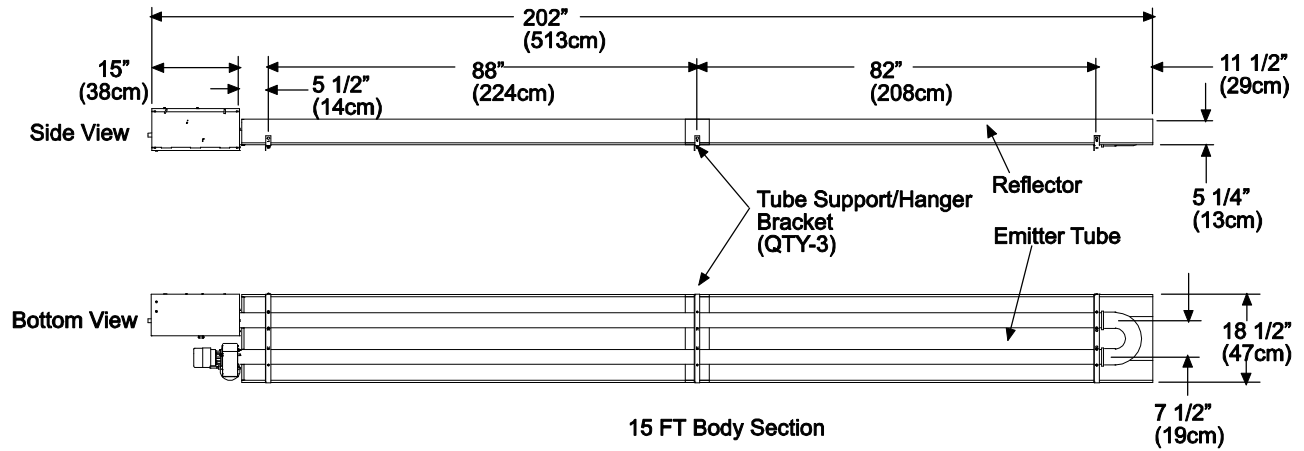

4A) DIMENSIONS - LTU80-250 SERIES

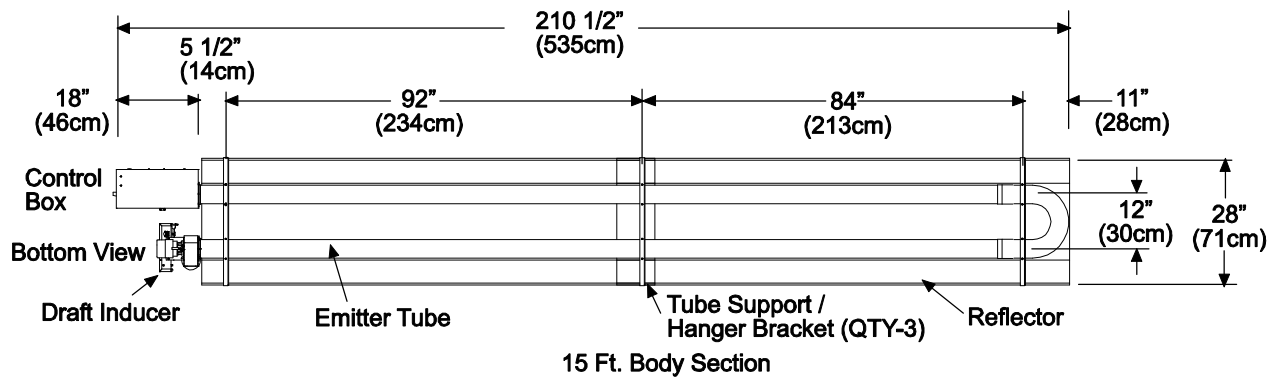

Models: LTU 80-130

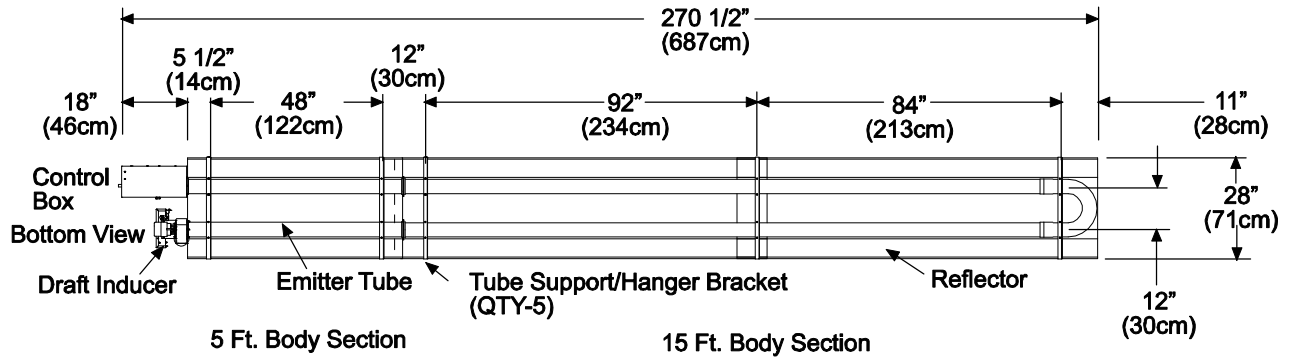

Models: LTU 125-175

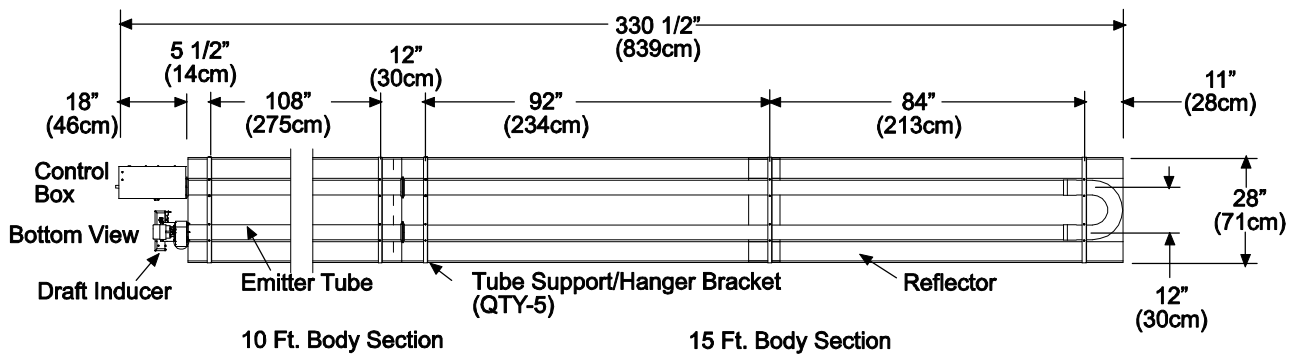

Models: LTU 180-250

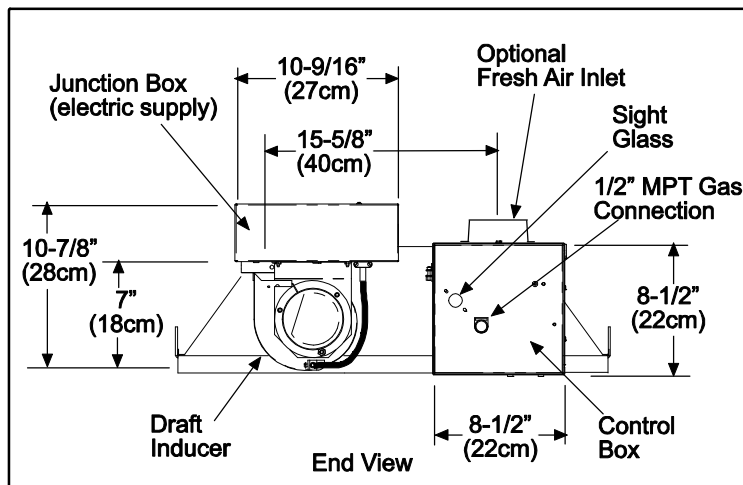

5) ACCESSORY PACKAGE

A. Exhaust Hood Package, Part #42924000

Contains:

Exhaust Hood Assembly, #42925540.....QTY-1
 #8-18 x 1/2 Self-Drilling Screws, #02189030.....QTY-2

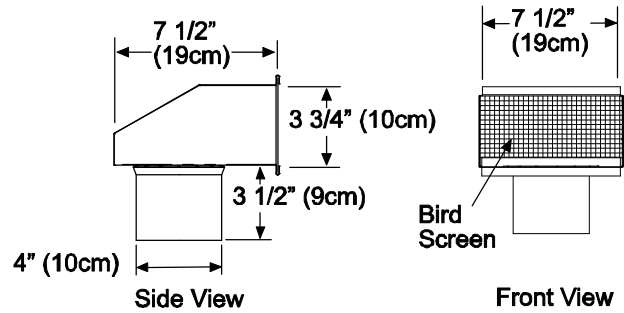

6) GAS CONNECTIONS

Certified connectors are recommended to be installed as shown, in one plane, and without sharp bends, kinks or twists. The gas take off from the drop line must be parallel to the burner gas inlet connection.

If the maximum supply pressure is less than 1/2 psig, a second stage regulator is not required.

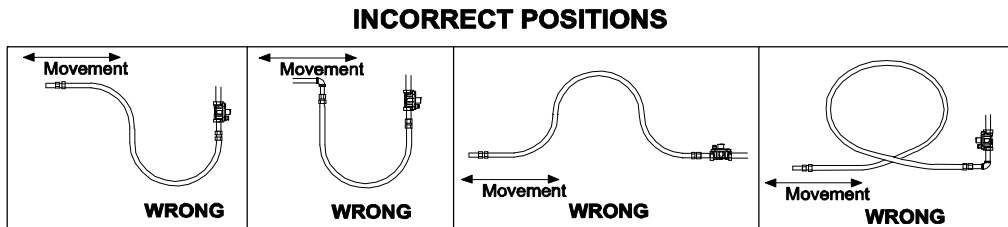
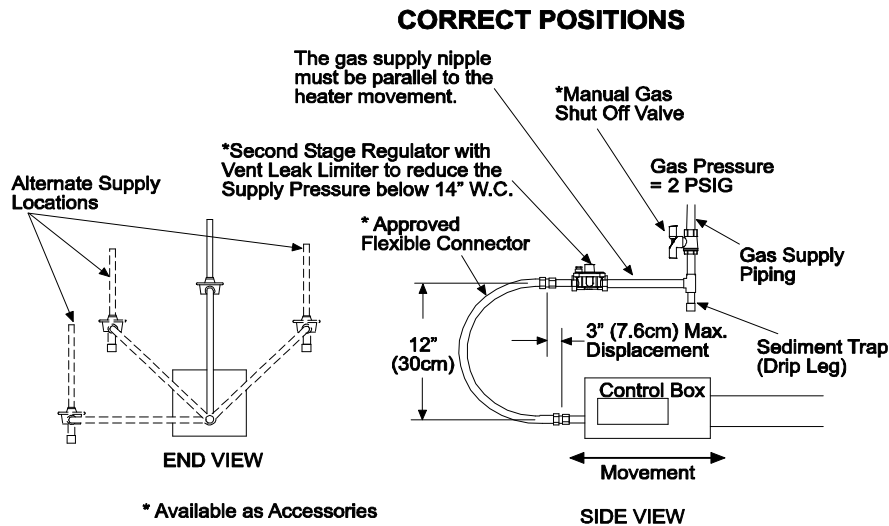

7) SINGLE STAGE - GAS PRESSURE TABLE

Supply Pressure – The installer will provide a 1/8" N.P.T. plugged tapping, accessible for test gauge connection immediately upstream of the gas supply connection to the heater.

GAS PRESSURE TABLE			
GAS TYPE	MANIFOLD PRESSURE	SUPPLY PRESSURE	
		Minimum*	Maximum
Natural Gas	3.5" W.C.	5" W.C. ¹	14" W.C.
Propane Gas	10.0" W.C.	11" W.C. ²	14" W.C.

* Minimum permissible gas supply pressure for purpose of input adjustment.

¹ 7" W.C. for LTS/U 150-250

² 12" W.C. for LTS/U 180-250

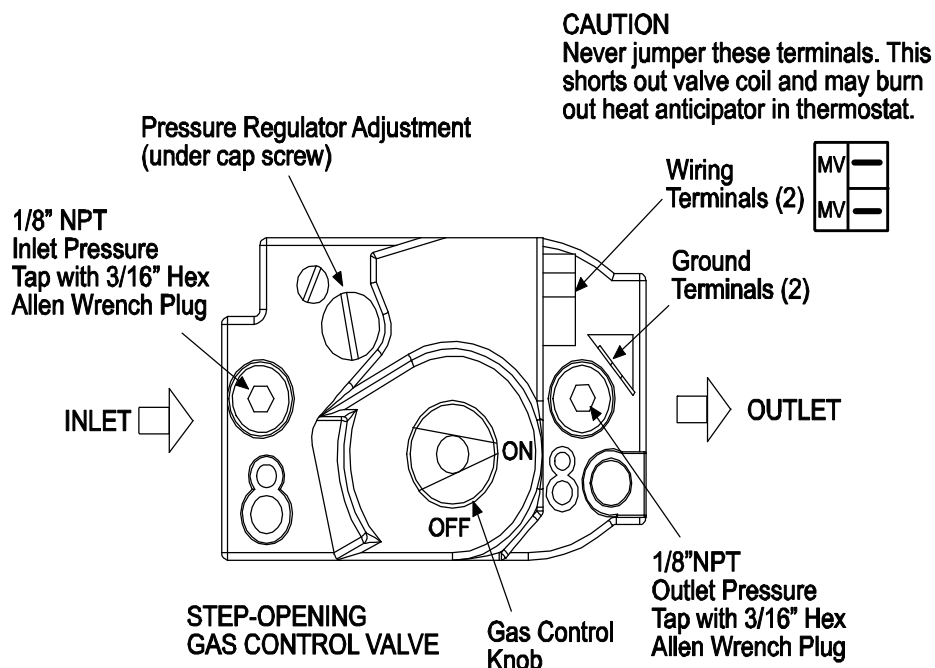

8) TWO STAGE - GAS PRESSURE TABLE

Supply Pressure – The installer will provide a 1/8" N.P.T. plugged tapping, accessible for test gauge connection immediately upstream of the gas supply connection to the heater.

GAS PRESSURE TABLE				
GAS TYPE	MANIFOLD PRESSURE		SUPPLY PRESSURE	
	High	Low	Minimum*	Maximum
Natural Gas	3.5" W.C.	1.4" W.C.	5" W.C. ¹	14" W.C.
Propane Gas	10.0" W.C.	4.0" W.C.	11" W.C. ²	14" W.C.

* Minimum permissible gas supply pressure for purpose of input adjustment.

¹ 7" W.C. for LTS/U 150-200

² 12" W.C. for LTS/U 180-200

10A) TWO STAGE - LTU80-200 - ELECTRICAL CONNECTIONS

TWO STAGE - INTERNAL CONNECTION WIRING DIAGRAM — Direct Spark Ignition

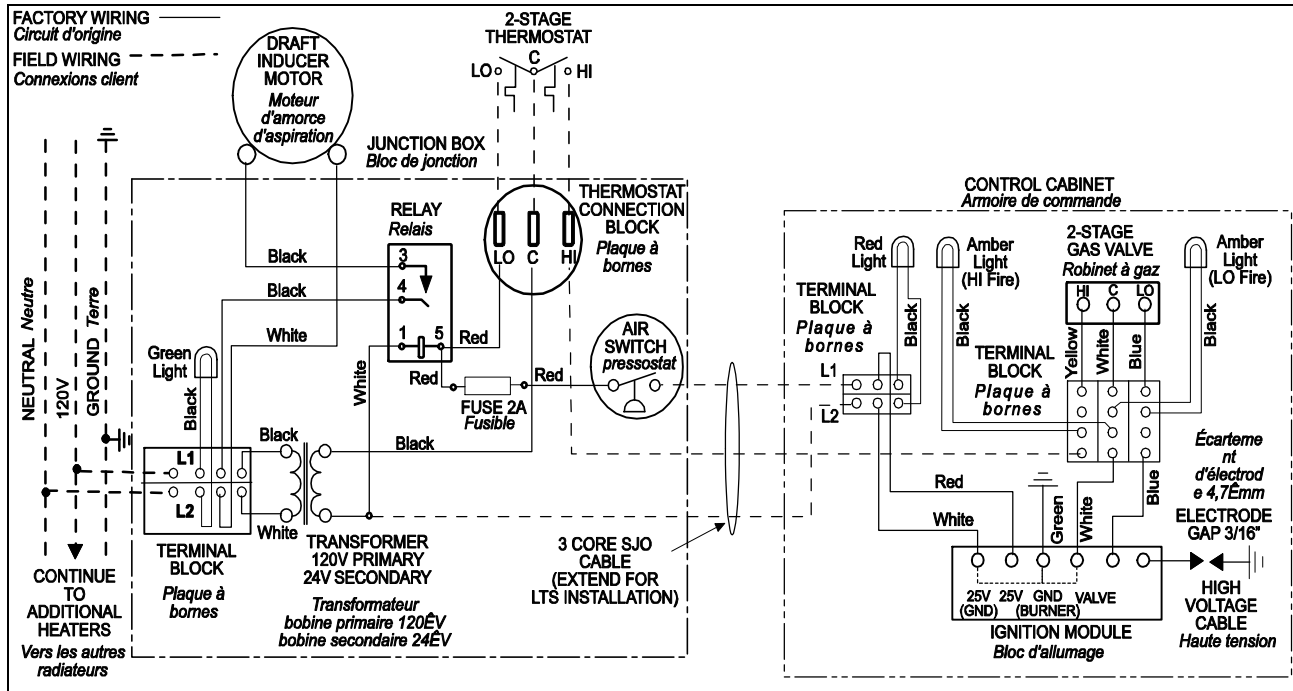

11) SINGLE STAGE - THERMOSTAT CONNECTIONS WIRING DIAGRAMS

A. LINE VOLTAGE (120V) THERMOSTAT CONNECTIONS - SINGLE HEATER PER THERMOSTAT - SINGLE STAGE

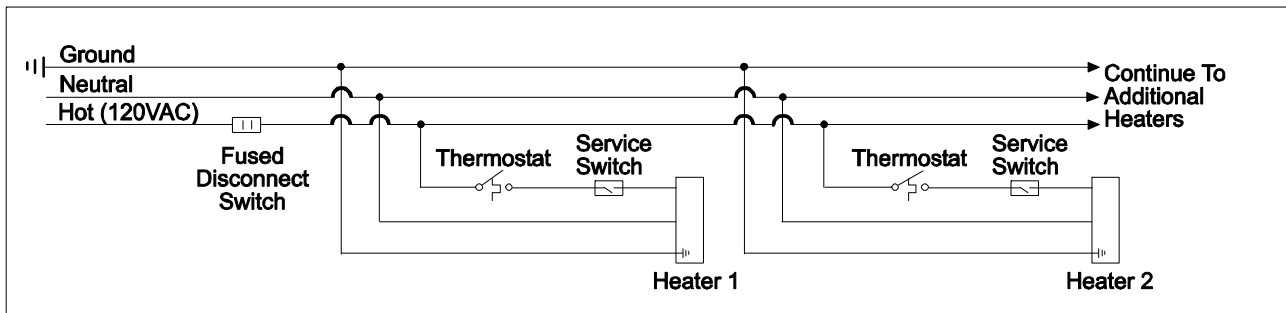

B. LINE VOLTAGE (120V) THERMOSTAT CONNECTIONS - MULTIPLE HEATERS PER THERMOSTAT - SINGLE STAGE

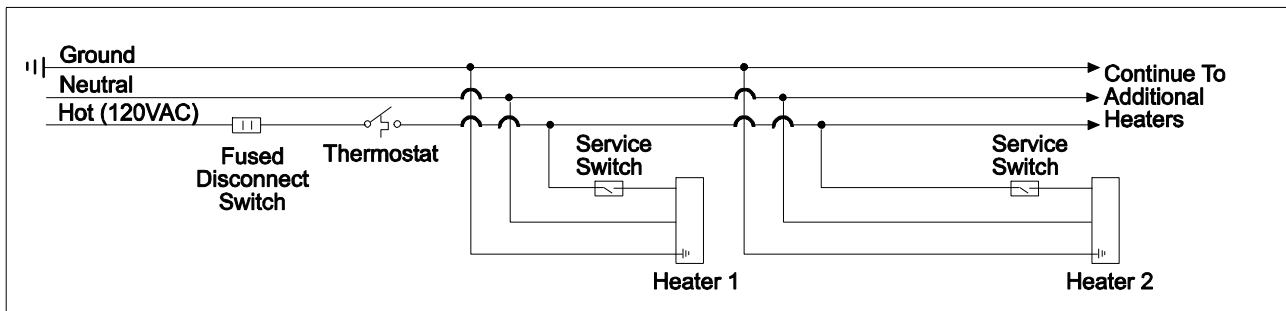

E. LOW VOLTAGE (24V) THERMOSTAT CONNECTIONS – MULTIPLE HEATERS PER THERMOSTAT

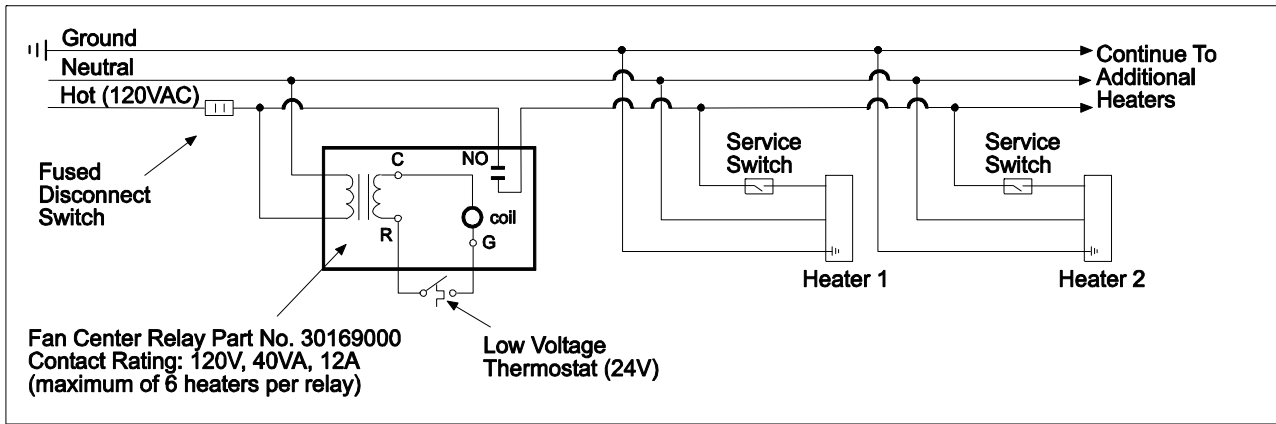

11A) TWO STAGE – THERMOSTAT CONNECTIONS WIRING DIAGRAMS

A. LOW VOLTAGE (24V) THERMOSTAT CONNECTIONS – SINGLE HEATER PER THERMOSTAT

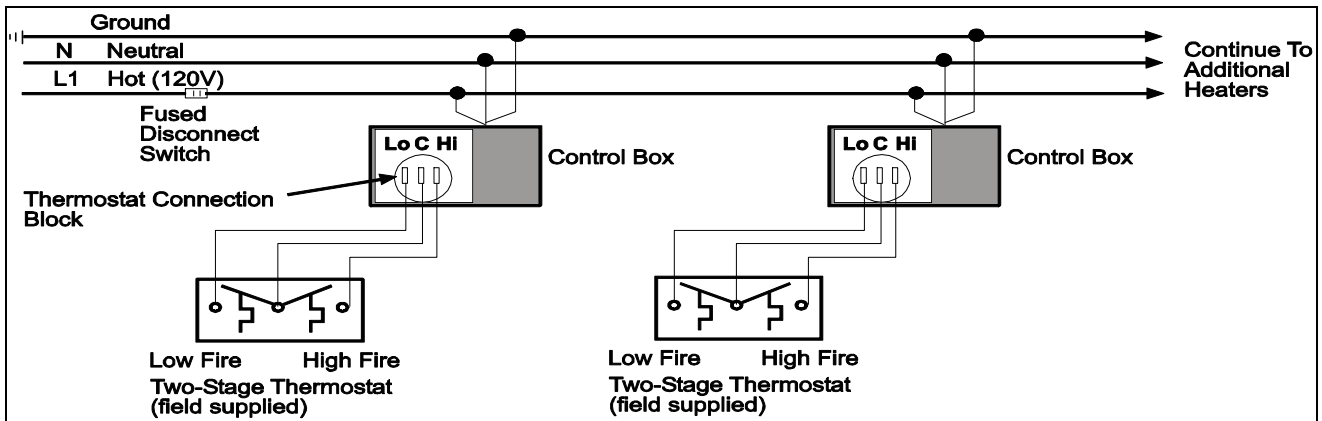

B. LOW VOLTAGE (24V) THERMOSTAT CONNECTIONS – MULTIPLE HEATERS PER THERMOSTAT

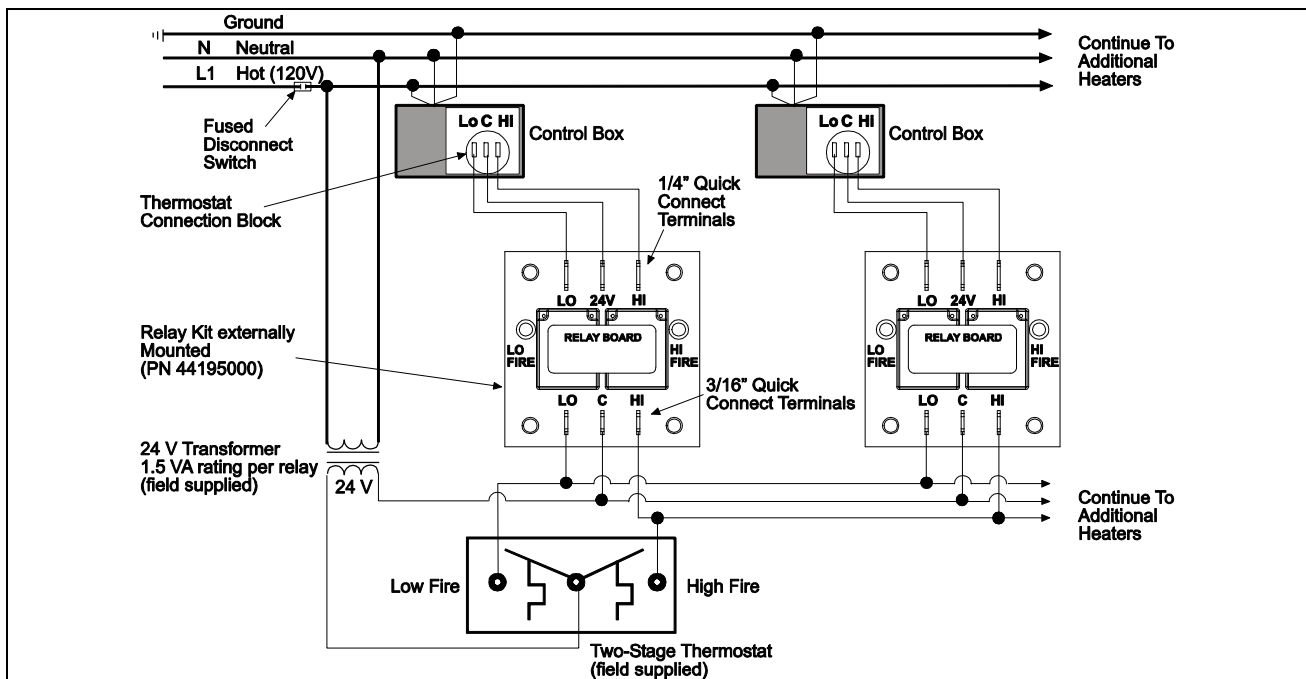

C. MANUAL SWITCH CONNECTIONS – SINGLE HEATER OPERATION PER DUAL MANUAL SWITCH

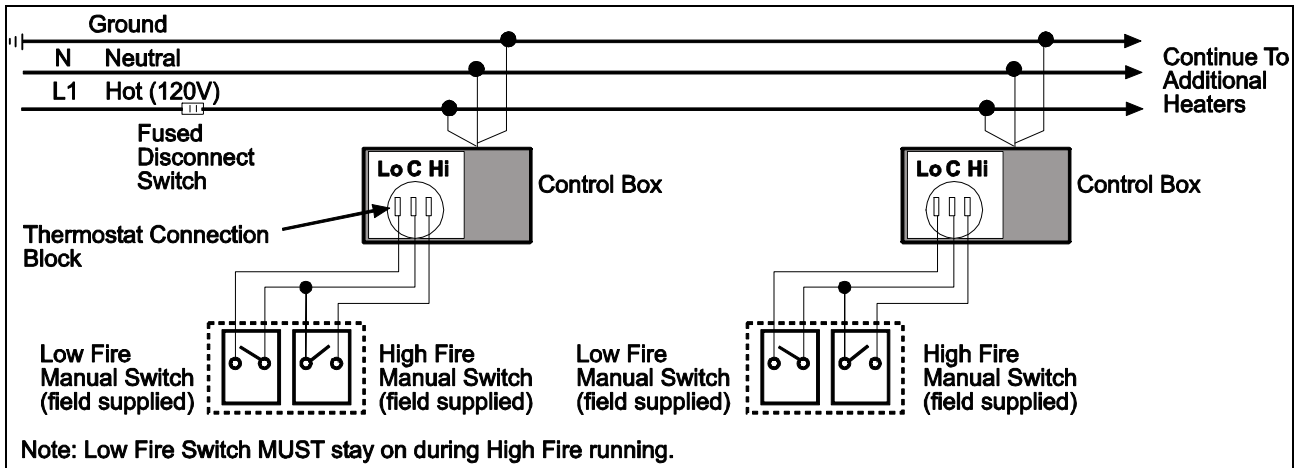

D. MANUAL SWITCH CONNECTIONS – MULTIPLE HEATERS OPERATION PER DUAL MANUAL SWITCH

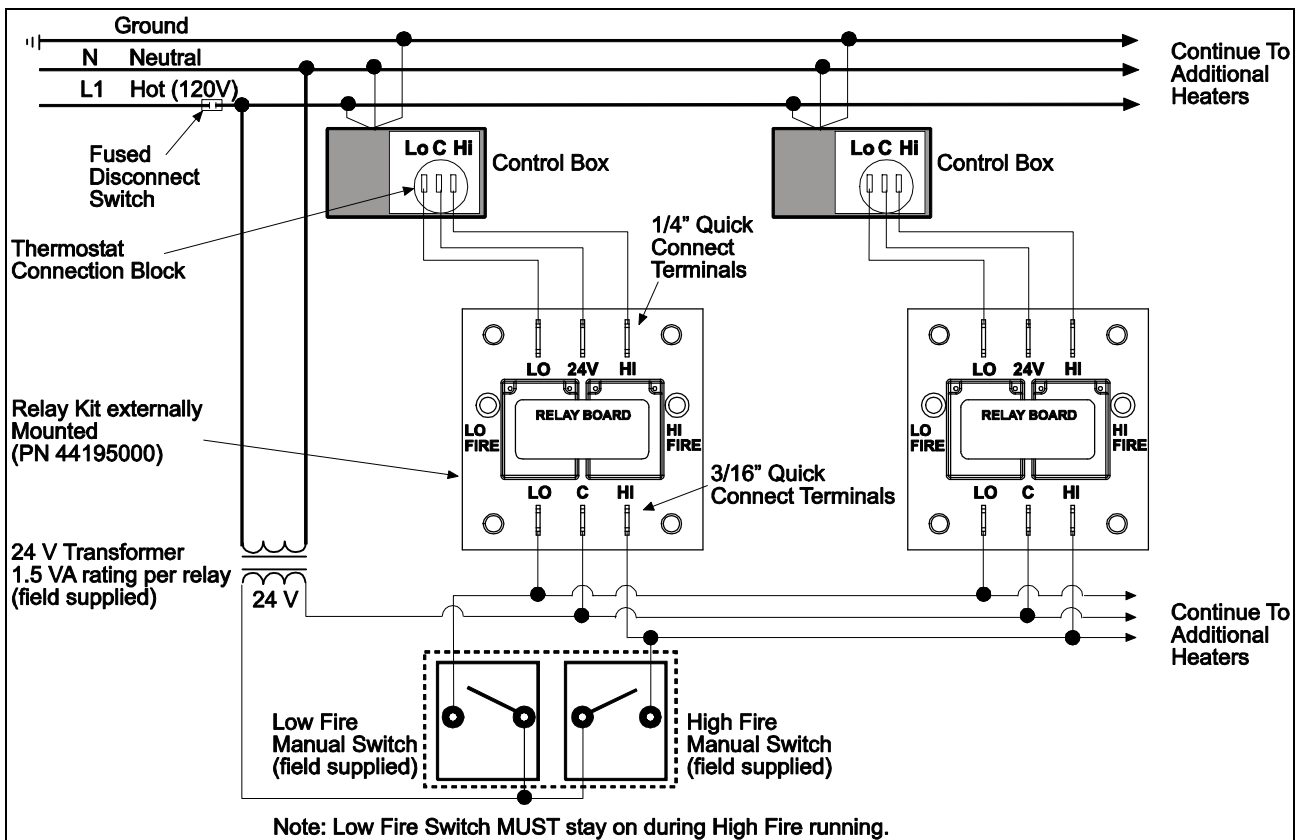

Note:

1. If any of the original wire as supplied with the appliance must be replaced, it must be replaced with wiring material having a temperature rating of at least 105°C. (18 Ga. CSA 600V Type TEW)
2. When connecting the supply circuit to the heater, wiring material having a minimum size of 14 AWG and a temperature rating of at least 90°C shall be used.

12) VENTING

- A. BASIC FLUE VENTING** - Venting must comply with the latest edition of the National Fuel Gas Code (ANSI Z223.1-latest edition) or the authority having jurisdiction. Other venting references are in the equipment volume of the ASHRAE Handbook.

SINGLE HEATER VENTING (VERTICAL THROUGH THE ROOF)

- When venting the heater to outside of building through a roof, use single-wall metal pipe. This is to be constructed of galvanized sheet metal or other approved noncombustible corrosion-resistant material as allowed by state or local codes.
- A vent passing through a combustible roof shall extend through an approved clearance roof thimble. Double-wall, Type B vent must be used for the portion of the vent system which passes through the combustible roof. An approved vent cap (Leslie "VersaCap"-Type B or equal) must be attached to end of the flue.
- The maximum equivalent length of vent pipe should be carefully observed. A safety switch in the heater is designed to shut the heater off before excessive flue restriction causes bad combustion. Refer to the Vent Sizing Table for vent pipe diameter.
 - Minimum Equivalent Length = 5 ft. of pipe
 - Maximum Equivalent Length = 100 ft. of 4" pipe for 40-175 Models and 6" pipe for 180-200 Models

Use the following correction factors to obtain the equivalent length:

- Subtract 15 ft. if the run is horizontal. (maximum horizontal length for 4" pipe is 25 ft.)
 - Subtract 10 ft. for an approved vent cap.
 - Subtract 10 ft. for each elbow beyond 15 ft. from the heater.
 - Subtract 15 ft. for each elbow within 15 ft. of the heater.
- Joints between sections of piping shall be fastened by sheet metal screws or other approved means and should be sealed to prevent leakage of flue gas into building. Aluminum or Teflon tape suitable for 550°F (3M Company tapes 433 or 363) or silicone sealant is recommended.
 - Avoid locating elbows in the first 5' of vent pipe whenever possible. Limit to (2) 90° elbows. When vent pipe is in a horizontal run, it must have 1/4 inch per foot rise.
 - All portions of the vent pipe shall be supported to prevent from sagging (6' spacing is recommended).
 - When the vent pipe passes through areas where the ambient temperature is likely to induce condensation of the flue gases, the vent pipe should be insulated and a condensation drain should be provided.
 - Minimum clearance for single-wall flue pipe to combustible material shall be 6 inches. This may be reduced when the combustible material is protected as specified in the National Fuel Gas Code or the authority having jurisdiction.
 - Single-wall metal pipe shall not originate in any unoccupied attic or concealed space and shall not pass through any attic, inside wall or concealed space, or through any floor. For the installation of a single-wall metal pipe through an exterior combustible wall, refer to latest edition of the National Fuel Gas Code or the authority having jurisdiction.
 - A venting system shall terminate at least 3 ft. above any forced air inlet located within 10 ft.

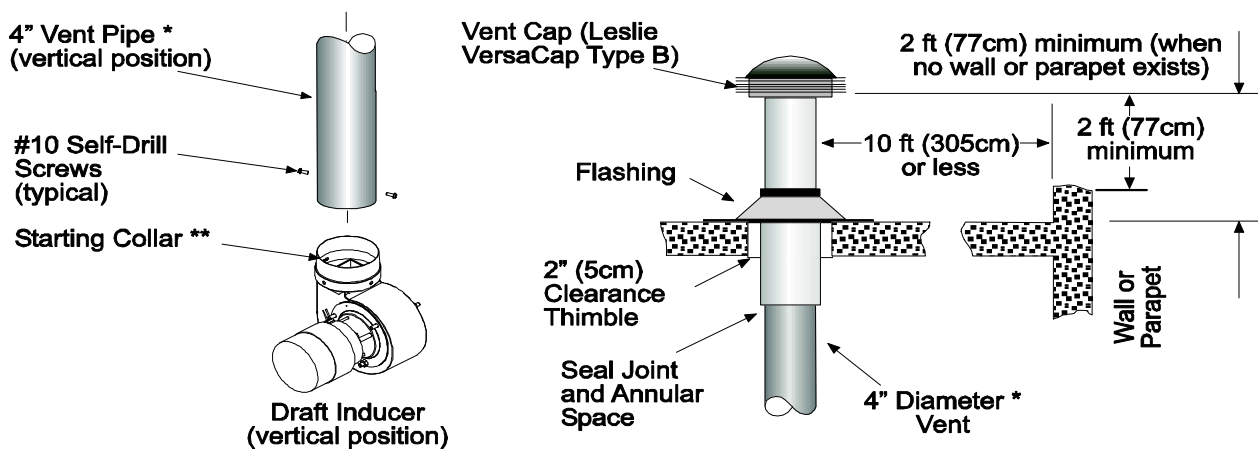

* 6" for LTS/U 180-250 Models

** 4"x6" Adaptor included for LTS/U 180-250 Models

Note: Junction Box is not shown.

SINGLE HEATER VENTING (HORIZONTAL THROUGH SIDEWALL)

When venting the heater horizontally through a combustible outside sidewall, the same requirements listed previously for venting

Vertical Through The Roof apply except as follows:

1. A vent passing through a combustible wall must pass through an approved clearance thimble (Air-Jet #4VT or Ameri-Vent #4EWT or other thimbles) that are listed by a nationally recognized testing agency. Double-wall Type B vent must be used for the portion of the vent system which passes through the combustible sidewall.
2. An approved vent cap (Breibert-Type L or equal) must be attached to the end of the vent pipe.
 - 4" vent – 25 ft. maximum with one 90° elbow and vent cap for 40-175 Models
 - 6" vent – 75 ft. maximum with maximum two 90° elbows and vent cap for all Models

If other horizontal vent configurations are required, consult the manufacturer.

NOTE: To minimize problems associated with condensation in long horizontal runs, vent pipe can be insulated.

3. When venting through a sidewall, the horizontal vent pipe shall rise not less than 1/4 inch per foot from the start of the vent system to the vent terminal. All portions of the vent pipe shall be supported to prevent sagging. (6' spacing is recommended)
4. A minimum clearance of 6 inches must be maintained between the outside wall and vent cap.
5. The horizontal venting system shall not terminate:
 - Less than 4 ft. (1.2m) below, 4 ft. (1.2m) horizontally from or 1 ft. (30cm) above any door, operable window or gravity air inlet into any building. The bottom of the vent terminal shall be located at least 7 ft. (2.1m) above grade or above snow accumulation level as determined by local codes.
 - Less than 3 ft. (0.9m) from a combustion air inlet.
 - Less than 3 ft. (0.9m) from any other building opening or any gas service regulator.
 - Less than 7 ft. (2.1m) above public walkways.
 - Directly over areas where condensate or vapor could create a nuisance or hazard or be harmful to the operation of gas utility meters, regulators, relief valves, or other equipment. Building materials should be protected from flue gases and condensate.
 - Less than 12" (0.30m) when directly below a combustible overhang.
6. In regions of the country where prevailing winds are consistently higher than 40 mph, it may be necessary to terminate the vent system above the roof level.

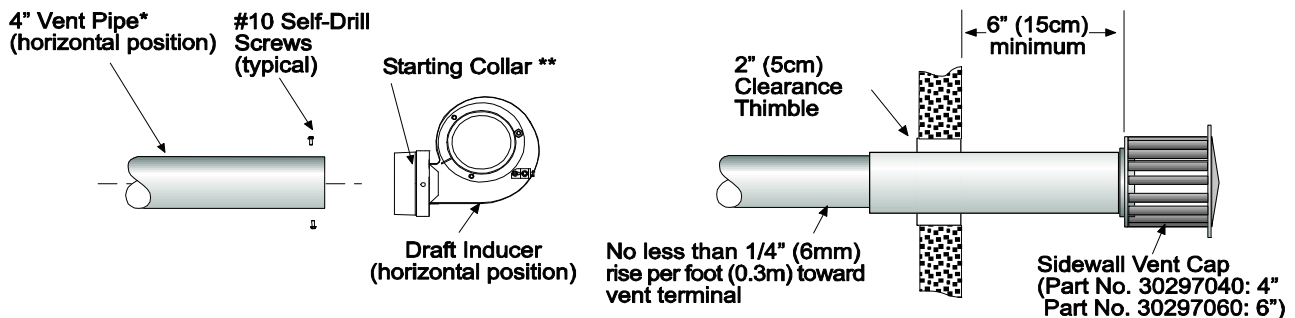

* 6" for LTS/U 180-200 Models

** 4"x6" Adaptor included for LTS/U 180-200 Models

Note: Junction Box is not shown.

MULTIPLE HEATER VENTING (CONNECTIONS INTO A COMMON VENT OR MANIFOLD)

Requirements for venting of multiple heaters are the same as described for **SINGLE HEATER VENTING** except as follows:

1. The common vent size and total vent height is normally determined by the number of heaters per common vent, length of horizontal connector runs, and connector rise. Connector lengths should be as short as possible and have a minimum 1/4 inch per foot rise. Without regard to connector rise and total vent height due to many possible venting configurations, the following should be observed:
 - Common vent pipe & vent connector diameter should be no less than that shown in the following Vent Sizing Table.
 - The connector length should be no more than 75% of the vertical portion of vent above the connector.
 - Where possible, use a Y-connector to the common vent.
2. Material for connectors should be constructed of galvanized sheet metal or other approved noncombustible corrosion resistant material as allowed by state or local codes. All common vent pipe should be double-wall, Type B vent.
3. Avoid unnecessary bends. Limit to two (2) 90° elbows.
4. The entire length of vent connector shall be readily accessible for inspection, cleaning and replacement.
5. Groups of heaters with a common vent must be controlled by a common thermostat.

Multiple Heater Vertical Venting Arrangement

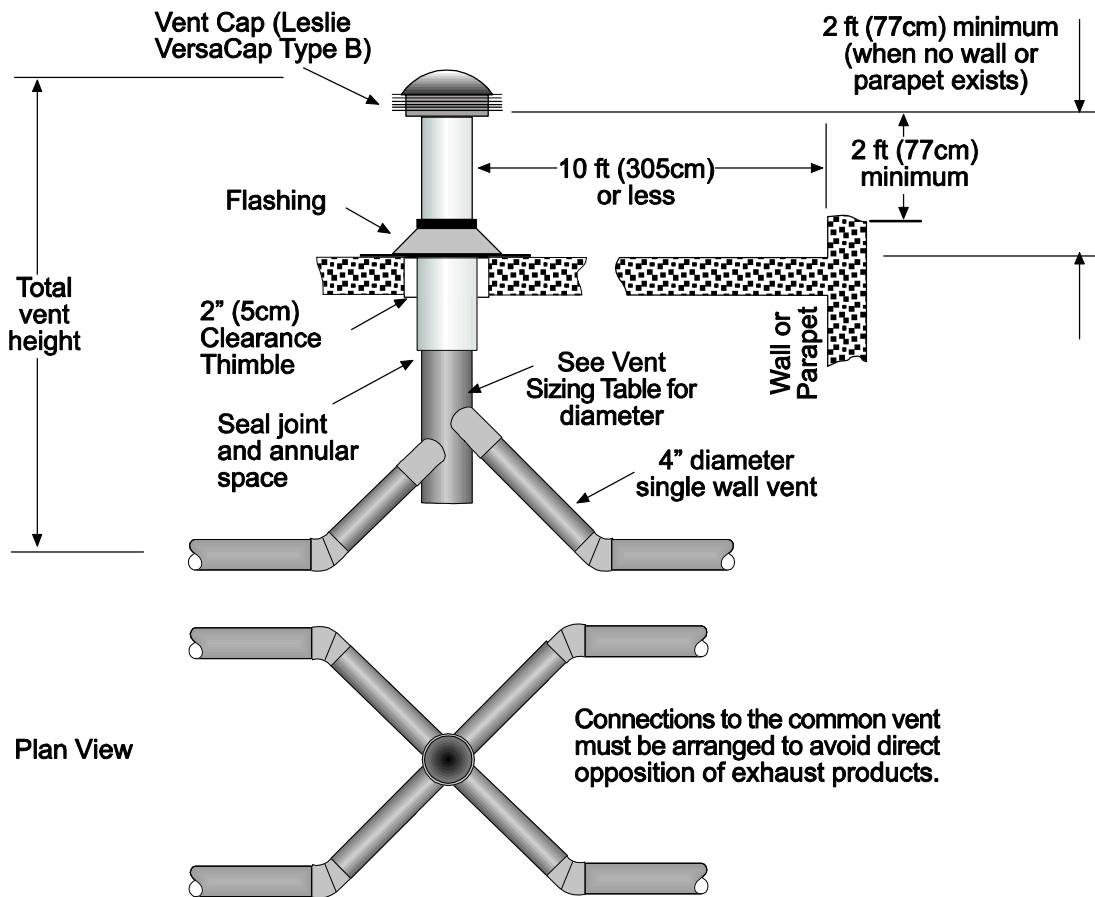

Multiple Heater Horizontal Venting Arrangement

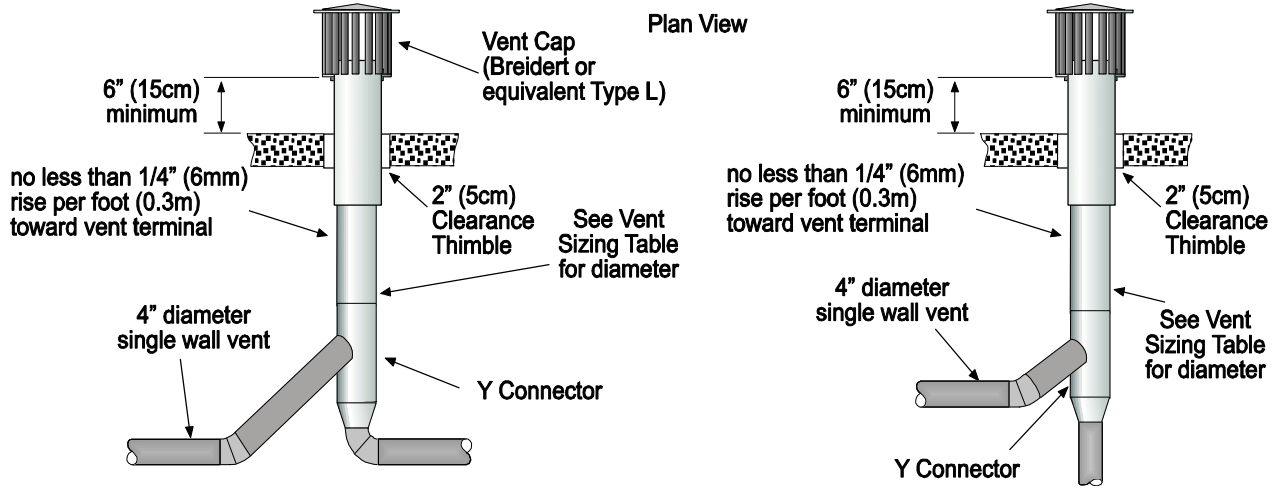

Multiple Heater Venting (Connections into a Manifold)

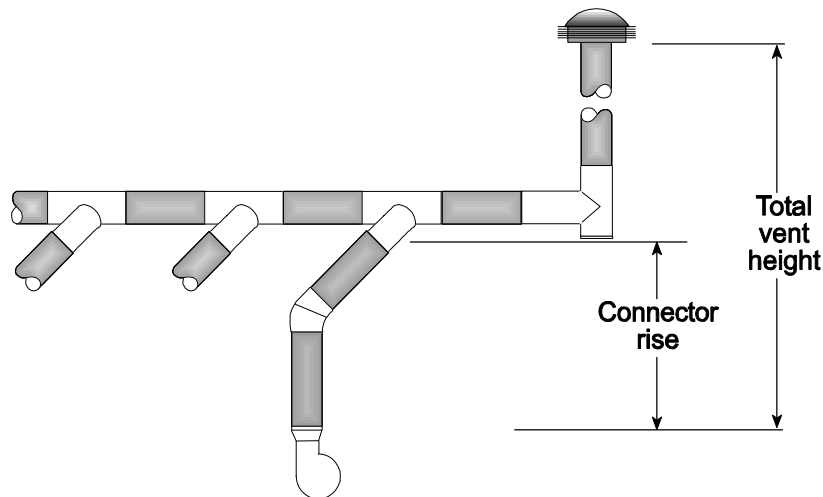

VENT SIZING TABLE — Multiple Heater Venting					
	Number of Heaters				
	1	2	3	4	5
LTS40-50	4"	4"	5"	5"	6"
LTS60-75	4"	5"	6"	6"	7"
LTS80-100	4"	6"	6"	7"	8"
LTS110-130	4"	6"	7"	8"	9"
LTS140-175	4"	6"	8"	9"	10"
LTS180-200	6"	8"	9"	10"	11"
LTS225-250	6"	9"	10"	11"	12"
COMMON VENT DIAMETER					
(If a size is not available use the next larger size.)					

13) AIR FOR COMBUSTION

If indoor combustion air is to be supplied for a tightly enclosed area, one square inch of free area opening shall be provided below the heater for each 1,000 Btu/hr of heater input. Adequate clearances around the perforated fresh air plate must be maintained at all times. In larger open areas of buildings, infiltration normally is adequate to provide air for combustion.

14) DIRECT OUTSIDE AIR FOR COMBUSTION

Outside combustion air should be supplied directly to the heater when the building is subject to negative pressure, or when contaminants or high humidity are present in the building air. These contaminants include paints, solvents, corrosive vapors or any other foreign particles that may cause damage to the heater or result in poor combustion.

Outside combustion air can be brought directly to the heater by a 6" diameter duct less than 50 ft. long or equivalent. This is attached to the 6" diameter starting collar. The starting collar is fitted to the top of the control box cabinet **after first removing and discarding the perforated cover**. An approved vent cap must be placed directly on the end of the outside combustion air inlet pipe. The combustion air inlet should be not less than 3 ft. (0.9m), either vertically or horizontally, from the flue vent termination. The air intake terminal must be located not less than 1 ft. (30cm) above grade. It is good installation practice to supply combustion air from the same pressure zone as the vent outlet. Avoid bringing combustion air to the heater from an attic space. There is no guarantee that adequate combustion air will be supplied.

If the heater is installed less than 2 ft. from the ceiling, a flexible transition section (e.g., flexible aluminum duct) must be provided to allow for expansion/contraction of straight tube heaters (LTS Series).

In colder climates, where necessary, insulate the outside combustion air duct. Avoid locating the outside combustion air duct directly above the control box. Provide a capped cleanout T as necessary. In high humidity applications, the control box should be sealed with silicone sealer.

In **multiple heater applications**, the combustion air intake may be ducted individually or common ducted in the same configuration as shown for venting in Section 13. For combustion air intake duct sizing, please refer to the **Vent Sizing Table** and use the diameter indicated, based on the number of heaters per duct.

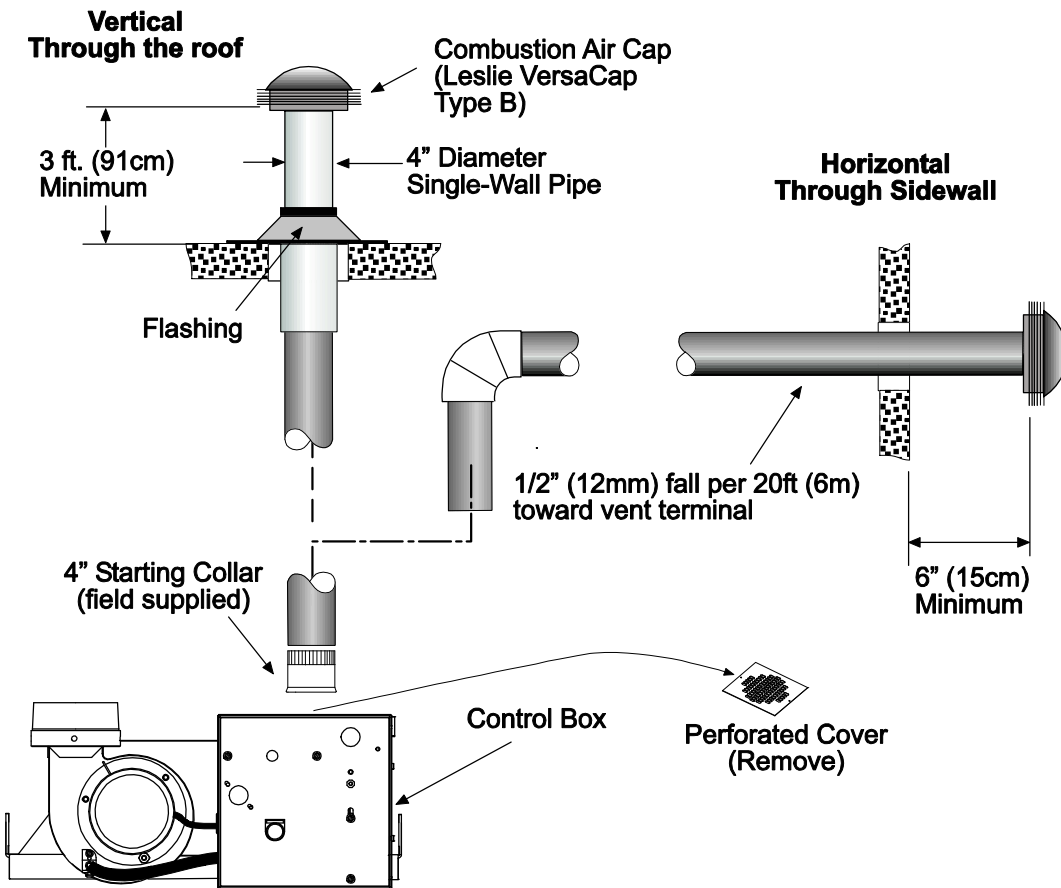
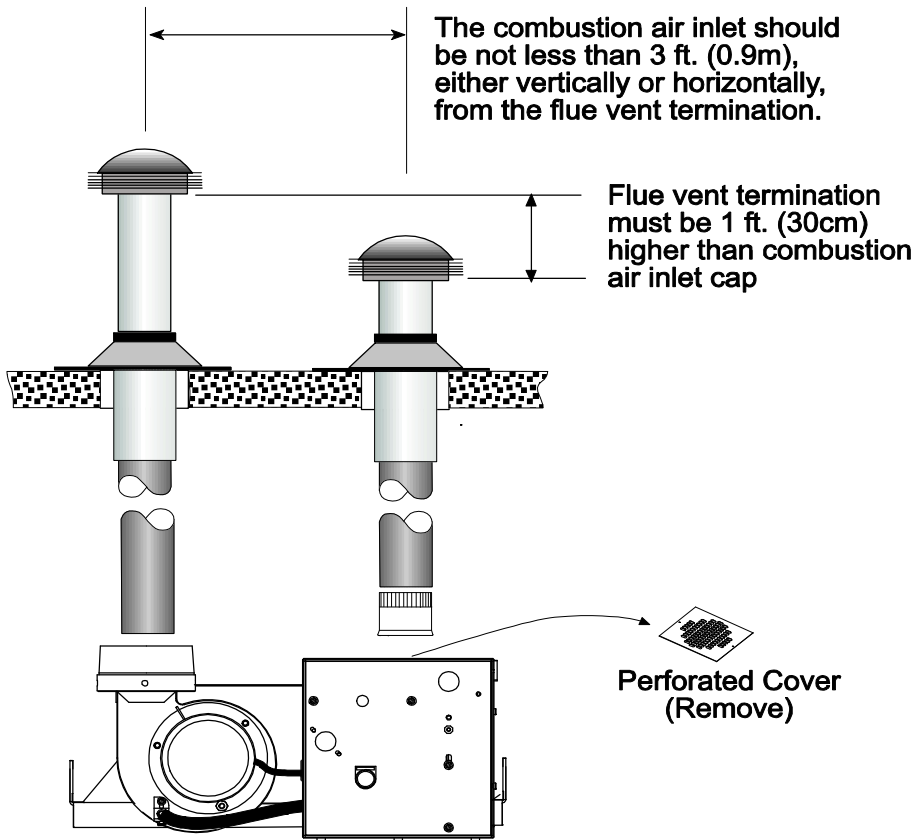

15) SINGLE STAGE - SEQUENCE OF OPERATION

The chart below shows the sequence of operation for the normal operating cycle.

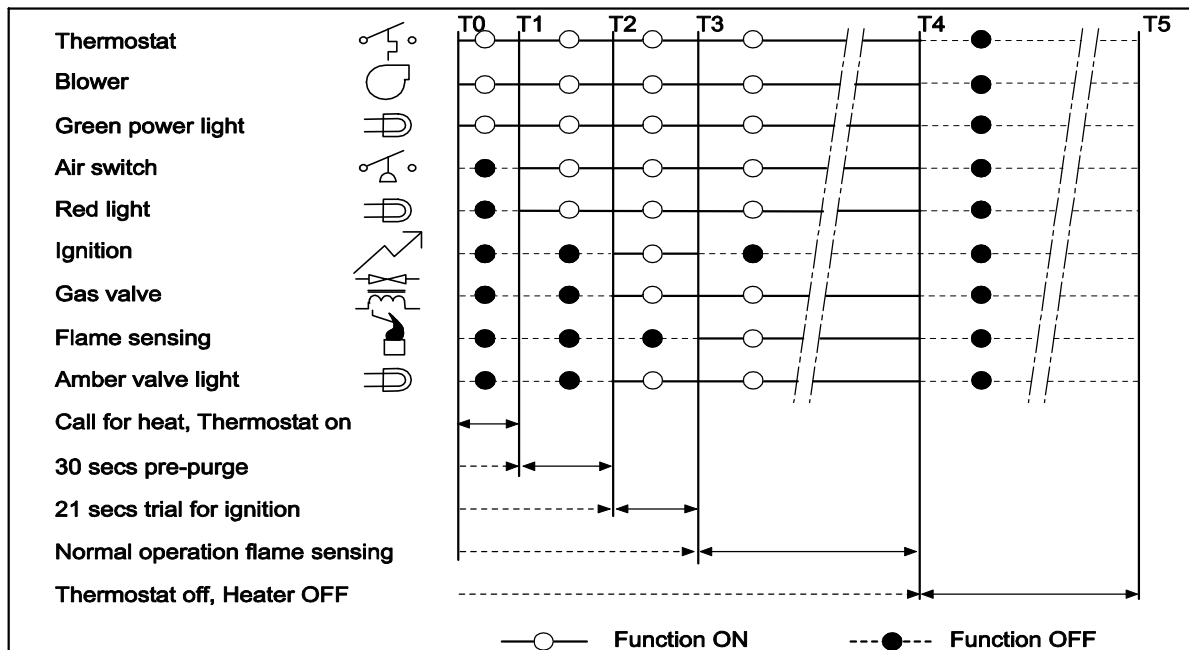

If the flame is not sensed during sequence T3 or T4, then the burner will automatically begin ignition as in sequence T2. If the flame is not re-established the heater will go to lockout.

16) TWO STAGE - SEQUENCE OF OPERATION

The chart below shows the sequence of operation for the normal operating cycle.

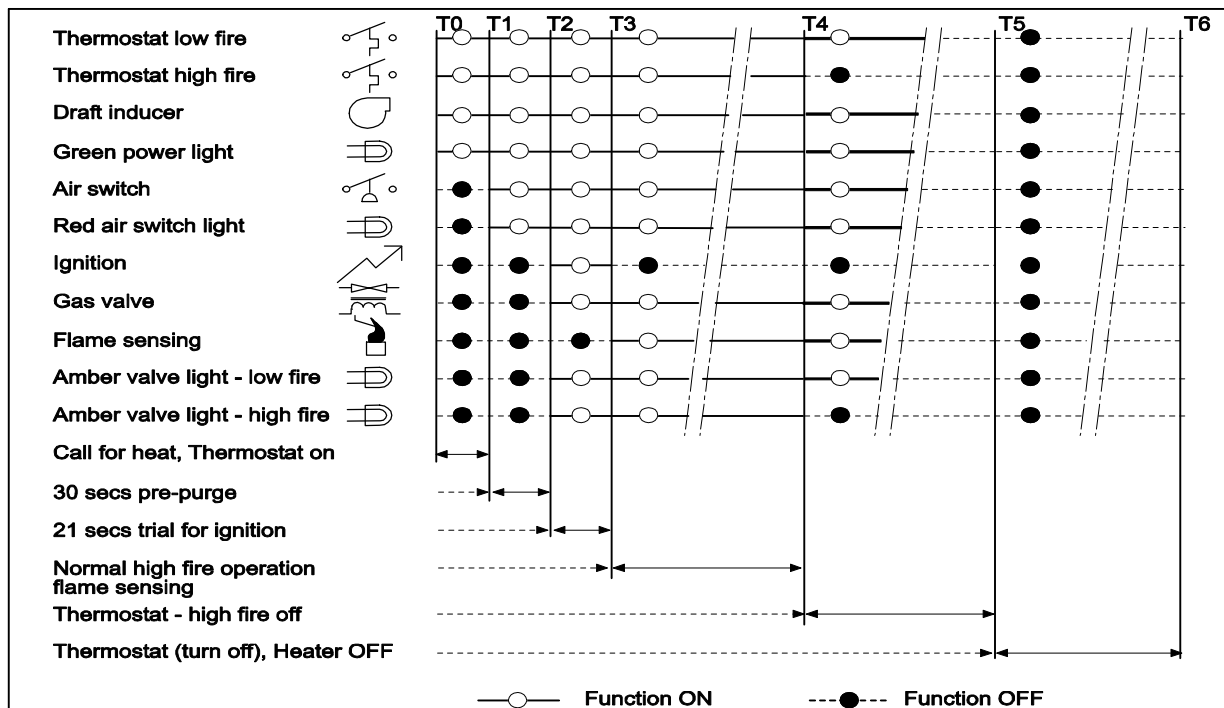

If the flame is not sensed during sequence T3 or T4, then the burner will automatically begin ignition as in sequence T2. If the flame is not re-established the heater will go to lockout.

17) LIMITED WARRANTY

LIMITED WARRANTY: Gas-Fired Products, Inc., the manufacturer, warrants to the original owner of any Space-Ray infrared gas heater that said heater will be free from defects in material or workmanship under normal use and service. The heater(s) shall be installed, used and maintained strictly in accordance with the manufacturer's instructions. The manufacturer's sole obligation under this warranty shall be limited to furnishing replacement parts, F.O.B. Charlotte, NC, for 12 months from the date of installation, or 18 months from the date of shipment by the manufacturer, whichever period shall expire first. Labor charges for removal of defective parts and the installation of the replacement parts are not included. This warranty applies only within the USA and Canada.

WARNING: Manufacturer's warranty shall not apply: (a) to damage to the heater when used in an atmosphere containing halogenated hydrocarbons or other corrosive chemicals. Some compounds in the air can be ingested into the equipment and can cause an accelerated rate of corrosion of some of the parts of the heating components. The use of such chemical compounds in or near the operating environment of the heater should be avoided where a longer heater life is desirable; (b) to any heater or components which have been repaired or replaced with other than factory parts, modified in any way, misused or damaged, or which have been used contrary to the manufacturer's written instructions. Replacement parts are available through Space-Ray representatives or their distributors.

LIMITATION OF WARRANTY: THERE ARE NO WARRANTIES, EXPRESS OR IMPLIED, WHICH EXTEND BEYOND THE DESCRIPTION ON THE FACE HEREOF. WITHOUT LIMITING THE FOREGOING, THE MANUFACTURER EXPRESSLY EXCLUDES ANY AND ALL IMPLIED WARRANTIES, INCLUDING BUT NOT LIMITED TO ANY IMPLIED WARRANTY OF FITNESS FOR A PARTICULAR PURPOSE AND ANY IMPLIED WARRANTY OF MERCHANTABILITY FOR ITS PRODUCTS.

If any provision of this warranty is found to be void, unenforceable or unconscionable, then the same is hereby severed and the remainder of this warranty is hereby saved and shall remain in force.

EXCLUSIVE REMEDY: The sole and exclusive remedy under this warranty is the replacement of the defective parts or heaters as hereinabove specified. THE MANUFACTURER DOES HEREBY EXPRESSLY EXCLUDE ANY AND ALL LIABILITY FOR INCIDENTAL AND CONSEQUENTIAL DAMAGES UNDER THIS OR ANY OTHER WARRANTY. Without intending to limit the aforesaid exclusion, THE MANUFACTURER DOES HEREBY EXCLUDE ANY LIABILITY UNDER THIS OR ANY OTHER WARRANTY FOR INJURIES AND COMMERCIAL LOSSES TO PROPERTY THAT RESULT FROM THE OPERATION, PROPER OR IMPROPER, OF ITS PRODUCTS.

ADDITIONAL WARRANTY ON HEAT EMITTING SURFACE AND BURNER: Manufacturer warrants to the original owner of any CSA design certified heater that, if installed, used and maintained strictly in accordance with the printed instructions received with the heater, the manufacturer will at any time during the below listed time periods, furnish at no cost to the original owner, replacement emitters or burners which have become inoperative by reason of any defect in our workmanship, materials or construction. The manufacturer's obligation under this warranty shall be limited to furnishing replacements under the following time periods from the date of installation:

	<u>Emitter</u>	<u>Burner</u>
LTU Series:	5 Years	10 Years

The manufacturer will not be responsible for labor charges incurred for removal or installation of emitters. Any transportation charges involved in the return or repair are excluded.

ADDITIONAL TERMS: Manufacturer assumes no liability for delay in performing its obligations under the aforesaid warranty. Manufacturer assumes no liability for failure in performing its obligations thereunder if failure results directly or indirectly from any cause beyond its control, including but not limited to acts of God, acts of Government, floods, fires, shortages of materials, strikes and other labor difficulties or delays or failures of transportation facilities.

This is a Non-Residential product. Installation and service shall be by a Licensed Contractor and in accordance with National and Local Codes.

When presenting warranty claims, proof of date of purchase must be submitted.

No Representative is authorized to assume for the manufacturer any liability except as set forth above.

SPACE-RAY®
A Division of Gas-Fired Products, Inc.
Post Office Box 36485 (28236) • 305 Doggett Street (28203) • Charlotte, North Carolina
Phone (704) 372-3485 • Fax (704) 332-5843 • www.spaceray.com email: info@spaceray.com