

1) GENERAL INFORMATION

This heater is a self-contained infrared radiant tube heater for use in locations where flammable gases or vapors are not generally present (as defined by OSHA acceptable limits) and is intended for the heating of **nonresidential** spaces.

INSTALLATION REQUIREMENTS

The installation must conform to local building codes or in the absence of local codes, with the National Fuel Gas Code ANSI Z223.1/NFPA54 or the Natural Gas and Propane Installation Code CSA B149.1. Heaters shall be installed by a licensed contractor or licensed installer. Clearances to combustibles as outlined in this manual should always be observed. In areas used for storage of combustible materials where they may be stacked below the heater, NFPA54 requires that the installer must post signs that will “specify the maximum permissible stacking height to maintain the required clearances from the heater to combustibles.”

Every heater shall be located with respect to building construction and other equipment so as to permit access to the heater. Each installer shall use quality installation practices when locating the heater and must give consideration to clearances to combustible materials, vehicles parked below, lights, overhead doors, storage areas with stacked materials, sprinkler heads, gas and electrical lines and any other possible obstructions or hazards. Consideration also must be given to service accessibility.

The heater, when installed in aircraft hangars and public garages, must be installed in accordance with ANSI/NFPA 409-latest edition (Standard for Aircraft Hangars), ANSI/NFPA 88a-latest edition (Standard for Parking Structures), and ANSI/NFPA 88b-latest edition (Standard for Repair Garages) with the following clearances:

- a. At least 10 feet above the upper surfaces of wings or engine enclosures of the highest aircraft that may be housed in the hangar and at least 8 feet above the floor in shops, offices, and other sections of hangars communicating with aircraft storage or service areas.
- b. At least 8 feet above the floor in public garages. **▲WARNING:** Minimum clearances marked on the heater must be maintained from vehicles parked below the heater.

(FOR CANADA ONLY)

- a. Installation of this appliance is to be in accordance with latest edition of CSA B149.1 (Natural Gas and Propane Installation Code).
- b. For installation in public garages or aircraft hangars, the minimum clearances from the bottom of the infrared heater to the upper surface of the highest aircraft or vehicle shall be 50 percent greater than the certified minimum clearance, but the clearance shall not be less than 8 feet.

Although these heaters may be used in many applications other than space heating (e.g., process heating), Space-Ray will not recognize the warranty for any use other than space heating.

This heater is for Indoor or Outdoor Installation and can be used in either Vented or Unvented mode. The term Unvented actually means Indirect Vented. While the products of combustion are expelled into the building, national codes require ventilation in the building to dilute these products of combustion. This ventilation may be provided by gravity or mechanical means.

This heater is not an explosion proof heater. Where the possibility of exposure to volatile and low flash point materials exists, it could result in property damage or death. This heater must not be installed in a spray booth where the heater can operate during the spraying process. Consult your local fire marshal or insurance company.

High Altitude:

Appliances are supplied as standard for altitudes of 0 to 2,000 feet (0-610 m). High-altitude ratings are obtained by a change in the orifice size. When ordered for high altitude installations, burners are supplied by the factory ready for high altitude installation. Check the nameplate for altitude before proceeding with the installation. In Canada the adjustment for altitude is made in accordance with Standard CGA 2.17, Gas-Fired Appliances for Use at High Altitudes.

2) MINIMUM CLEARANCES TO COMBUSTIBLES

Minimum clearances to combustibles shall be measured from the outer surfaces as shown in the following diagram:

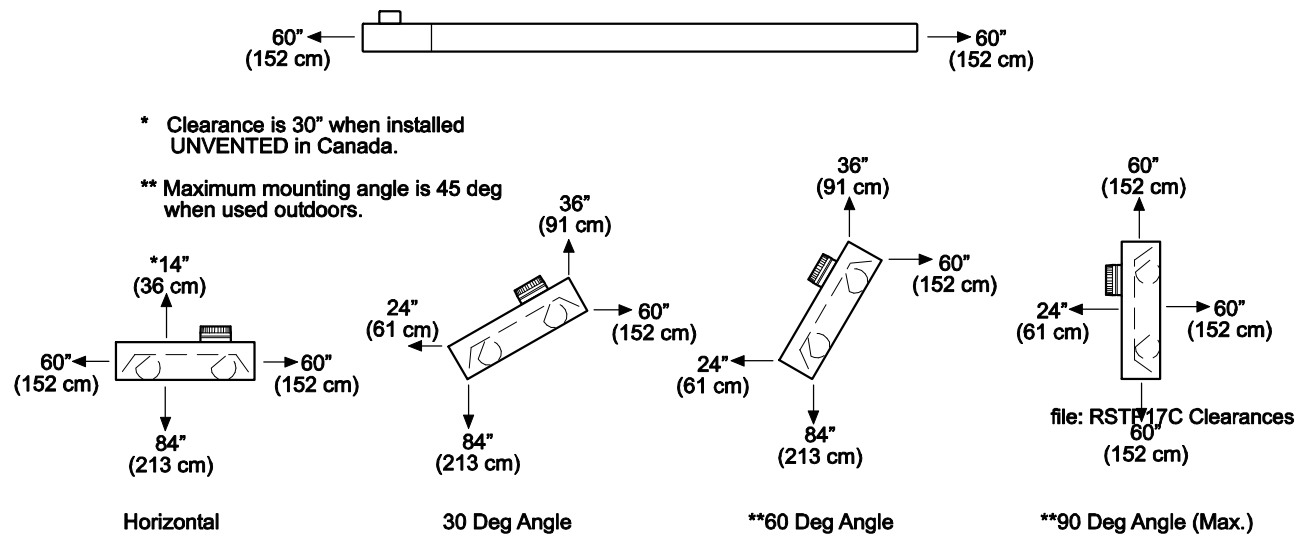

▲ WARNING: Certain materials or objects, when stored under the heater, will be subjected to radiant heat and could be seriously damaged. Observe the Minimum Clearances to Combustibles listed in the manual and on the heater at all times.

NOTE: The clearances specified above must be maintained to combustibles and other materials that may be damaged by temperatures 90°F above ambient temperature. Clearances to combustibles are posted on the control box. In areas used for storage of combustible materials where they may be stacked below the heater, NFPA54 requires that the installer must post signs that will "specify the maximum permissible stacking height to maintain the required clearances from the heater to combustibles." Space-Ray recommends posting these signs adjacent to the heater thermostat or other suitable location that will provide enhanced visibility.

3) SPECIFICATIONS

| Model No. | Btu/hr Input | Orifice Size | | Weight (lbs.) | | Minimum * Mounting Height | |
|-------------|--------------|--------------|-------------|---------------|------|---------------------------|-------------|
| | | Natural Gas | Propane Gas | Shipping | Unit | @ Horizontal | @ 45° Angle |
| RSTP15C-N5D | 150,000 | #1 (0.220) | n/a | 256 | 216 | 14 ft. | 12 ft. |
| RSTP17C-N5D | 175,000 | "D" (0.246) | n/a | 256 | 216 | 16 ft. | 14 ft. |
| RSTP17C-L5D | 175,000 | n/a | #26 (0.147) | 256 | 216 | 16 ft. | 14 ft. |

- MOUNT HEATERS AS HIGH AS POSSIBLE. Minimums are shown as a guideline for human comfort and uniform energy distribution for complete building heating applications. Consult your Space-Ray representative for the particulars of your installation requirements.

| Type Gas | Gas Pipe Connection | Tube Diameter | Flue Connection | Fresh Air Connection | Electrical Supply | Current Rating |
|--------------------|---------------------|---------------|-----------------|----------------------|-------------------------|----------------|
| Natural or Propane | ½" MPT (Male) | 4" | 6" Round | 6" Round | 120 Volt, 60Hz, 1 Phase | 2.6 Amp |

| Fuse Rating: | Ignition System (direct spark): |
|--|---------------------------------|
| Spark Module: 3 Amp 250V (for 24V Circuit) | 30 second pre-purge period |

4) DIMENSIONS

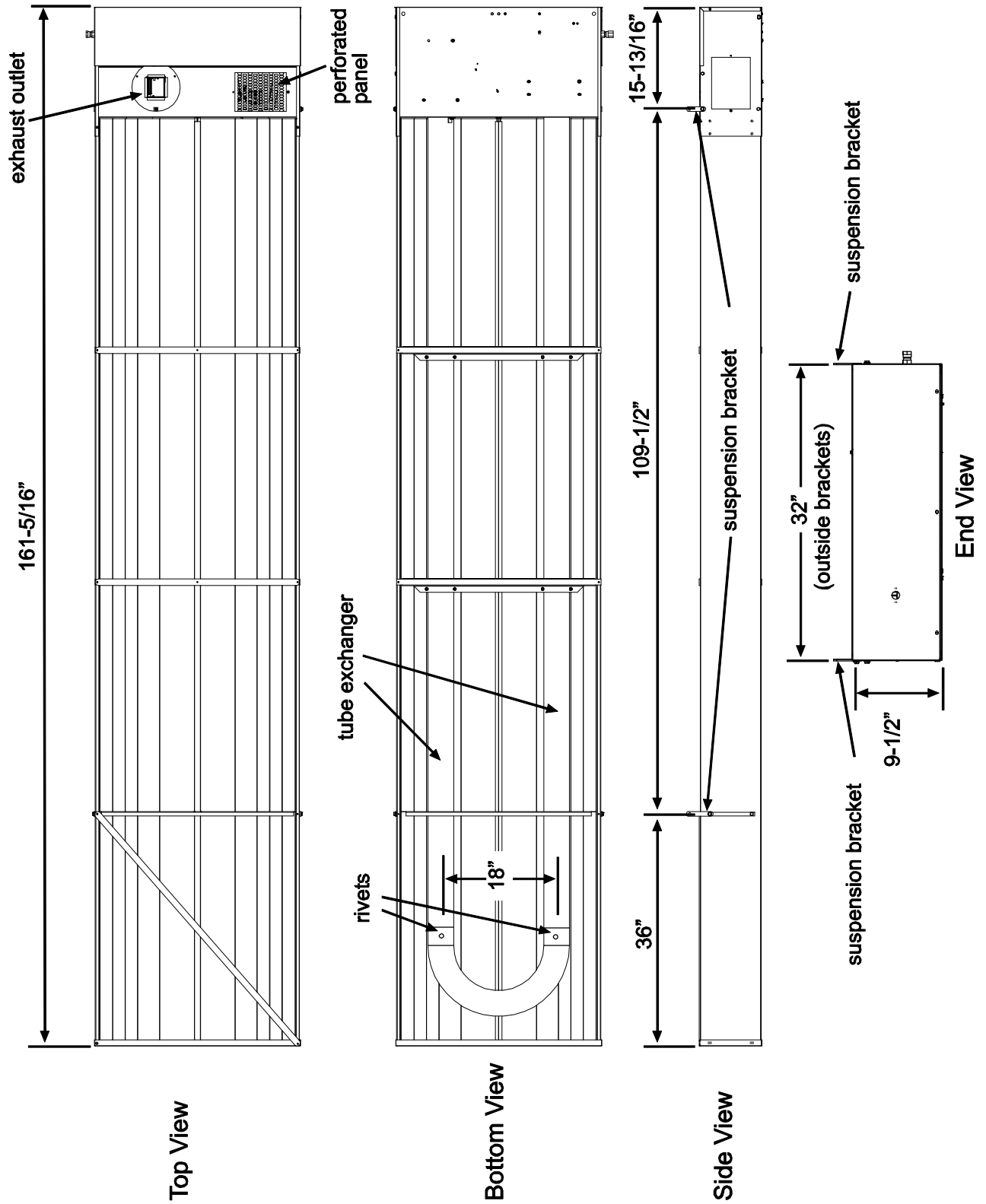

5) ACCESSORY PACKAGES

A. Indoor Unvented Kit, Part #42406000

Contains:

Exhaust Hood, #42401000.....QTY-1
#10-24 x 3/8 Screws, #02168010.....QTY-2
Form, #42407000.....QTY-1

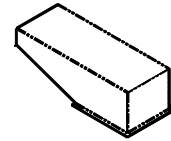

Exhaust Hood

B. Outdoor Kit, Part #42411000

Contains:

Exhaust Hood, #42401000.....QTY-1
Inlet Air Hood, #42408000.....QTY-1
Foam Strip, #42001040.....QTY-1
#10-24 x 3/8 Screws, #02168010.....QTY-4
Form, #42412000.....QTY-1

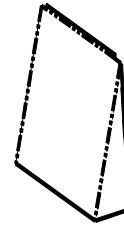

Inlet Air Hood

C. "L" Bracket Kit for 90° mounting, Part #42929000

Contains:

"L" Bracket, #42400000.....QTY-4



6) HEATER ASSEMBLY OVERVIEW

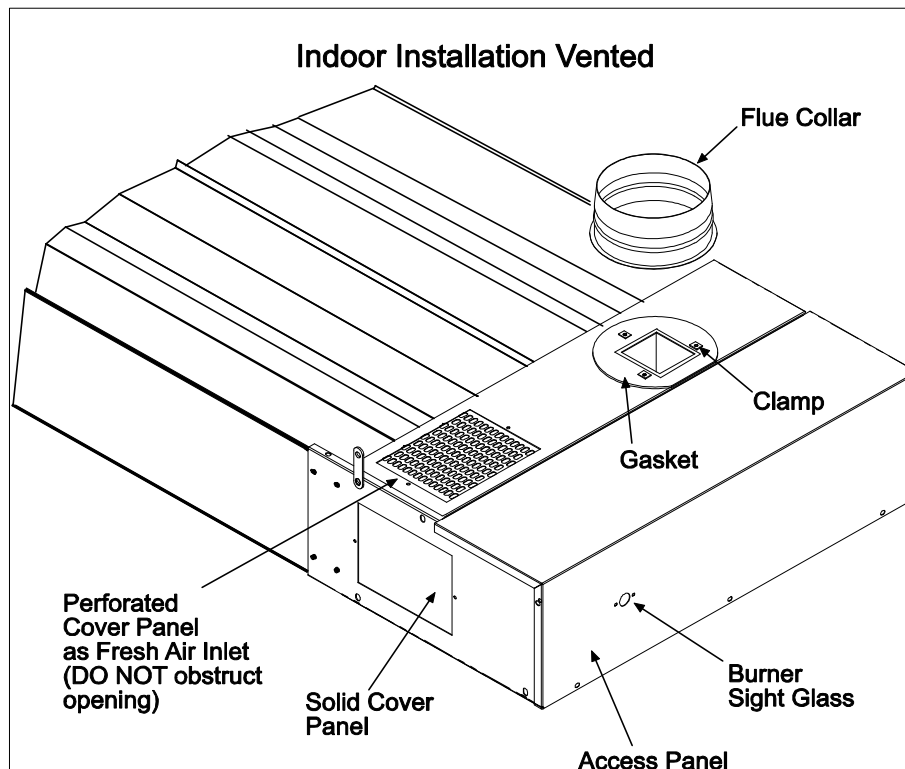

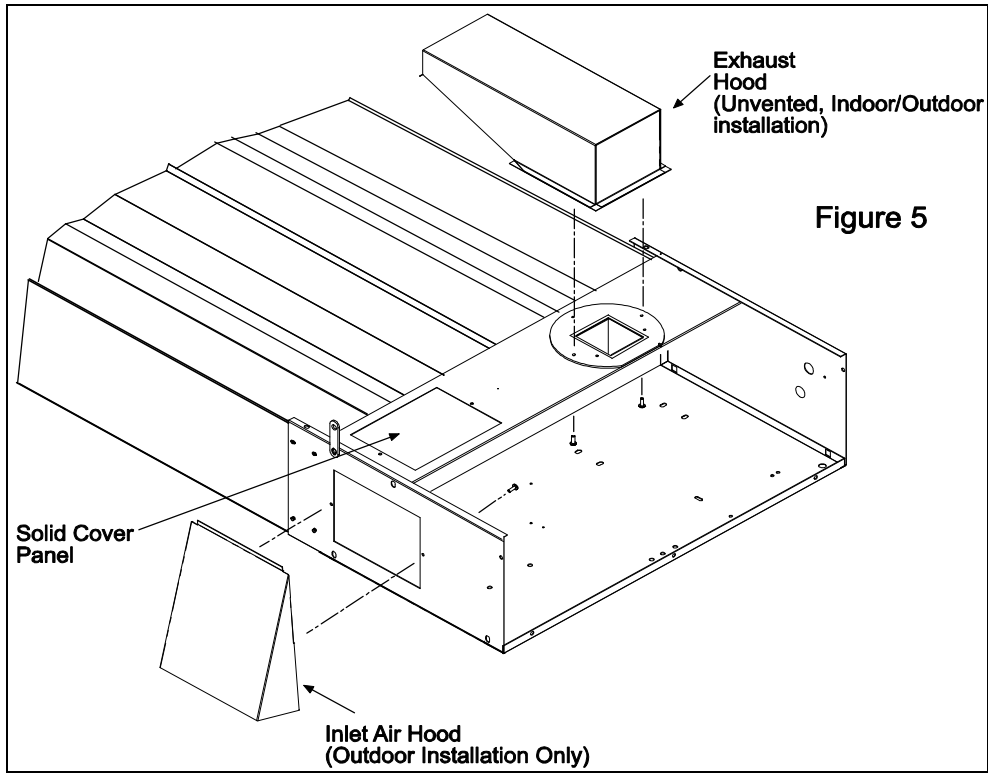

7) GAS CONNECTIONS

KEY DIMENSIONS AND COMPONENTS OF THE GAS CONNECTIONS

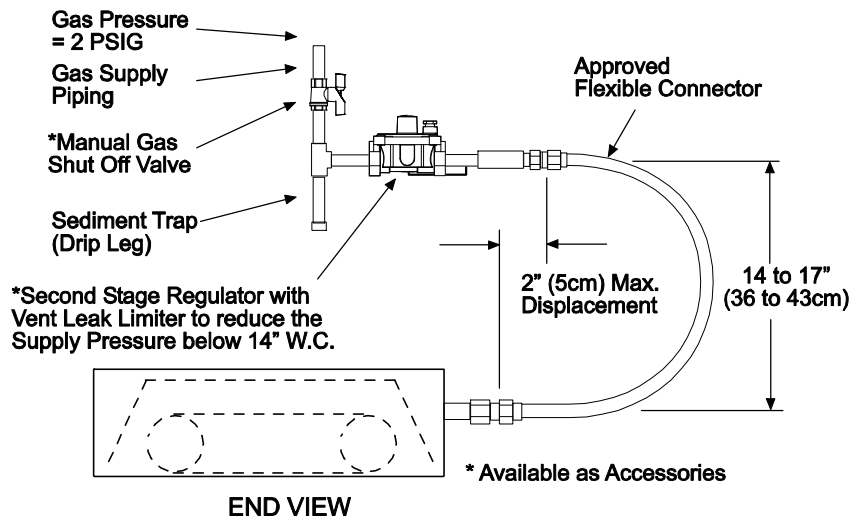

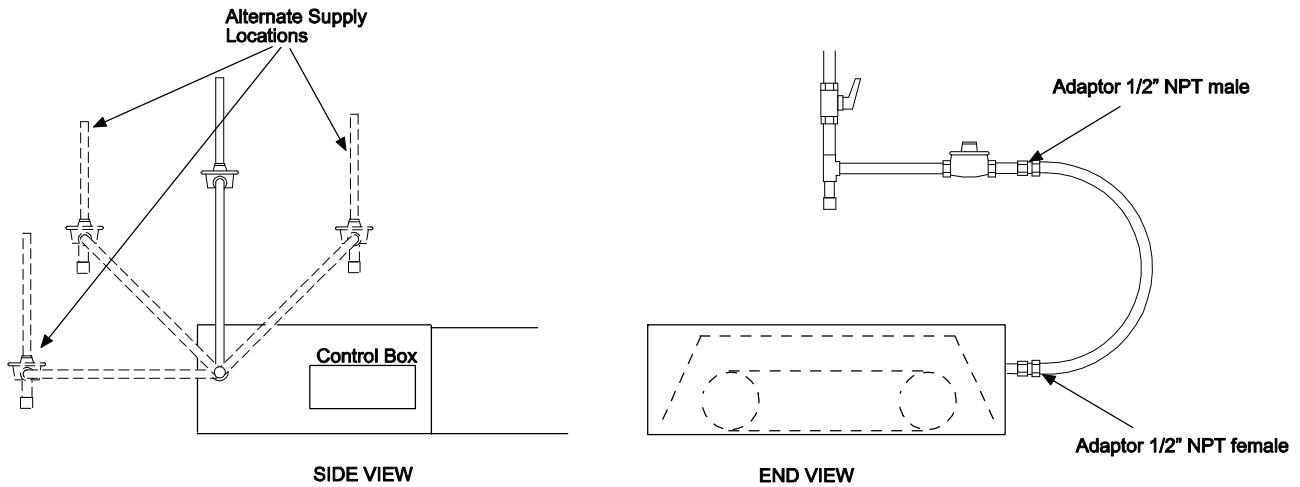

INCORRECT POSITIONS

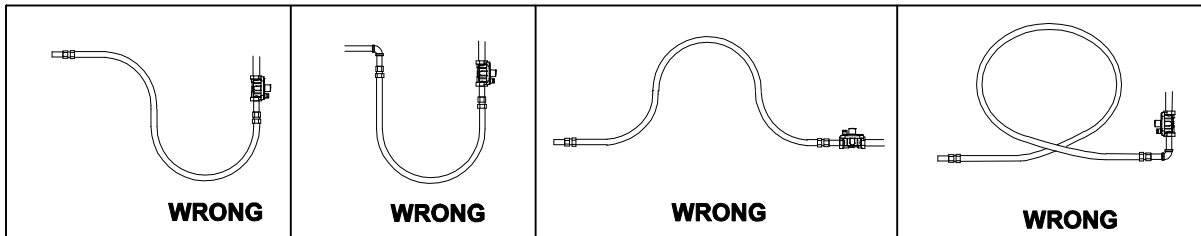

8) GAS PRESSURE TABLE

| GAS PRESSURE TABLE | | | |
|--------------------|-------------------|-----------------|----------|
| GAS TYPE | MANIFOLD PRESSURE | SUPPLY PRESSURE | |
| | | Minimum* | Maximum |
| Natural Gas | 3.5" W.C. | 7" W.C. | 14" W.C. |
| Propane Gas | 10.0" W.C. | 11" W.C. | 14" W.C. |

- Minimum permissible gas supply pressure for purpose of input adjustment.

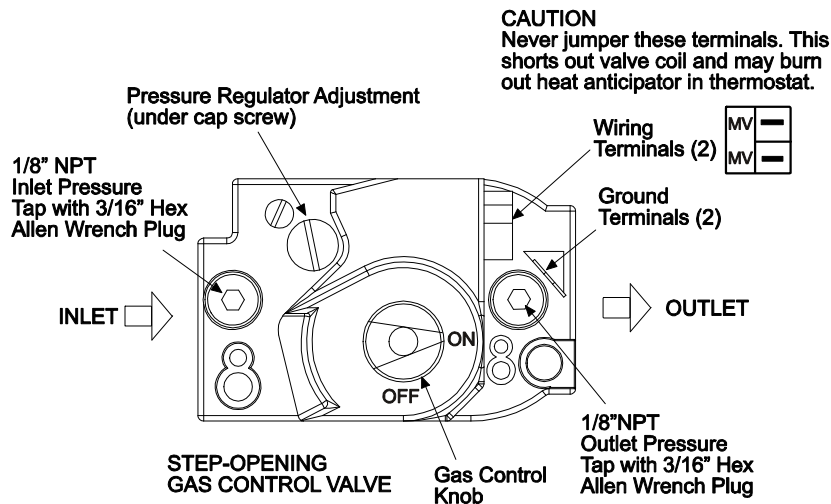

CAUTION
Never jumper these terminals. This shorts out valve coil and may burn out heat anticipator in thermostat.

This appliance is equipped with a step-opening, combination gas valve. The maximum supply pressure to the appliance is 14" W.C. or 1/2 P.S.I. If the line pressure is more than the maximum supply pressure, then a second stage regulator, which corresponds to the supply pressure, must be used.

9) ELECTRICAL CONNECTIONS

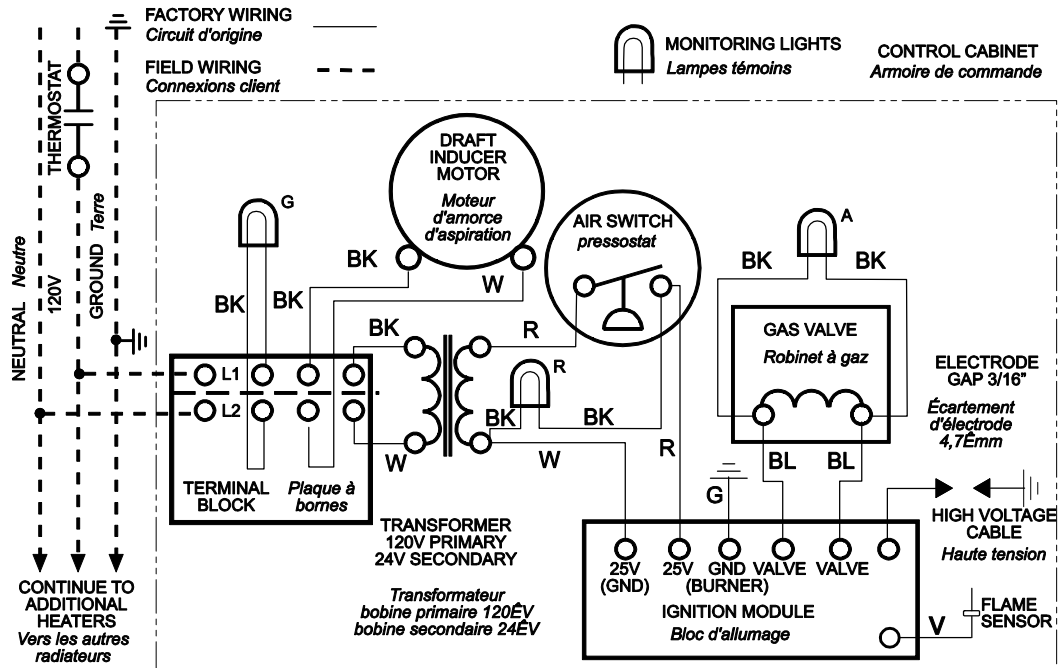

10) THERMOSTAT CONNECTIONS

A. LINE VOLTAGE (120V) THERMOSTAT CONNECTIONS - SINGLE HEATER PER THERMOSTAT

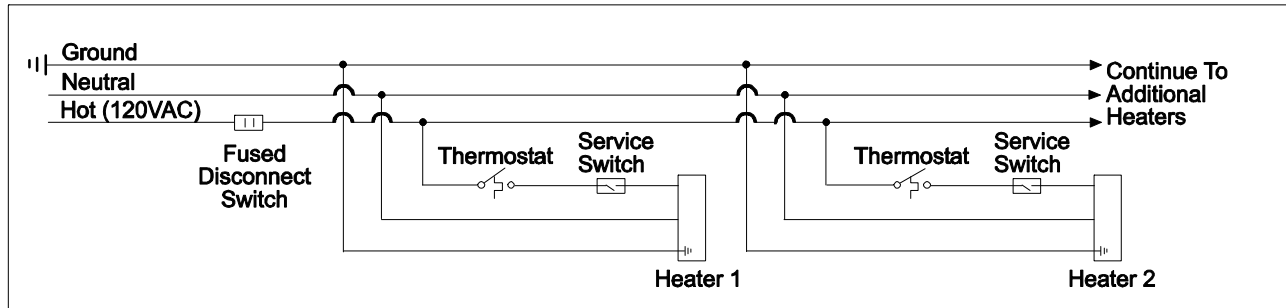

B. LINE VOLTAGE (120V) THERMOSTAT CONNECTIONS - MULTIPLE HEATERS PER THERMOSTAT

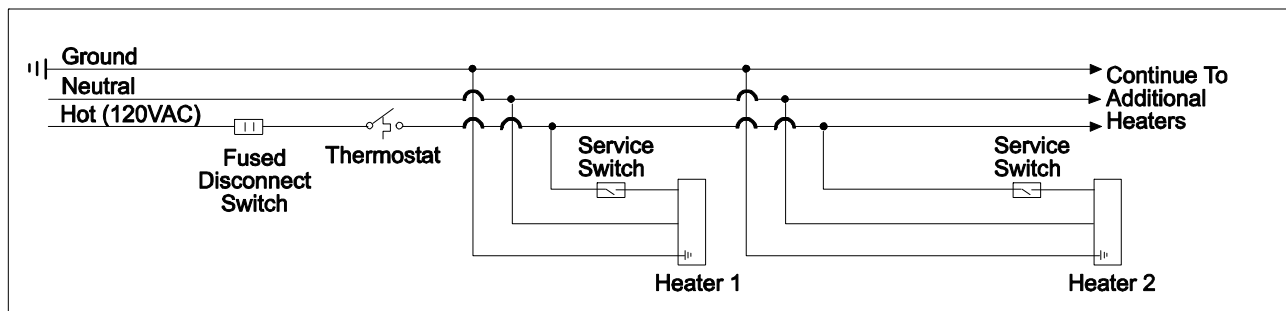

11) VENTING

- A. BASIC FLUE VENTING** — Venting must comply with the latest edition of the National Fuel Gas Code (ANSI Z223.1-latest edition) or the authority having jurisdiction. Other venting references are in the equipment volume of the ASHRAE Handbook.

| VENT SIZING TABLE — Multiple Heater Venting | | | | | | | |
|---|-------------------|----|-----|-----|-----|-----|-----|
| | Number of Heaters | | | | | | |
| | 1 | 2 | 3 | 4 | 5 | 6 | 8 |
| RSTP15 and RSTP17 | 6" | 8" | 10" | 11" | 12" | 12" | 14" |
| COMMON VENT DIAMETER (If a size is not available use the next larger size.) | | | | | | | |

SINGLE HEATER VENTING (VERTICAL THROUGH THE ROOF)

- When venting the heater to outside of building through a roof, use single-wall metal pipe. This is to be constructed of galvanized sheet metal or other approved noncombustible corrosion-resistant material as allowed by state or local codes.
- A vent passing through a combustible roof shall extend through an approved clearance roof thimble. Double-wall, Type B vent must be used for the portion of the vent system which passes through the combustible roof. An approved vent cap (Leslie "VersaCap"-Type B or equal) must be attached to end of the flue.
- The maximum equivalent length of vent pipe should be carefully observed. A safety switch in the heater is designed to shut the heater off before excessive flue restriction causes bad combustion. Refer to the Vent Sizing Table for vent pipe diameter.
 - Minimum Equivalent Length = 5 ft. of pipe
 - Maximum Equivalent Length = 100 ft. of pipe
 Use the following correction factors to obtain the equivalent length:
 - Subtract 15 ft. if the run is horizontal.
 - Subtract 10 ft. for an approved vent cap.
 - Subtract 10 ft. for each elbow beyond 15 ft. from the heater.
 - Subtract 15 ft. for each elbow within 15 ft. of the heater.
- Joints between sections of piping shall be fastened by sheet metal screws or other approved means and should be sealed to prevent leakage of flue gas into building. Aluminum or Teflon tape suitable for 550°F (3M Company tapes 433 or 363) or silicone sealant is recommended.
- Avoid locating elbows in the first 5' of vent pipe whenever possible. Limit to (2) 90° elbows. When vent pipe is in a horizontal run, it must have 1/4 inch per foot rise.
- All portions of the vent pipe shall be supported to prevent from sagging (6' spacing is recommended).
- When the vent pipe passes through areas where the ambient temperature is likely to induce condensation of the flue gases, the vent pipe should be insulated and a condensation drain should be provided.
- Minimum clearance for single-wall flue pipe to combustible material shall be 6 inches. This may be reduced when the combustible material is protected as specified in the National Fuel Gas Code or the authority having jurisdiction.
- Single-wall metal pipe shall not originate in any unoccupied attic or concealed space and shall not pass through any attic, inside wall or concealed space, or through any floor. For the installation of a single-wall metal pipe through an exterior combustible wall, refer to latest edition of the National Fuel Gas Code or the authority having jurisdiction.
- A venting system shall terminate at least 3 ft. above any forced air inlet located within 10 ft.

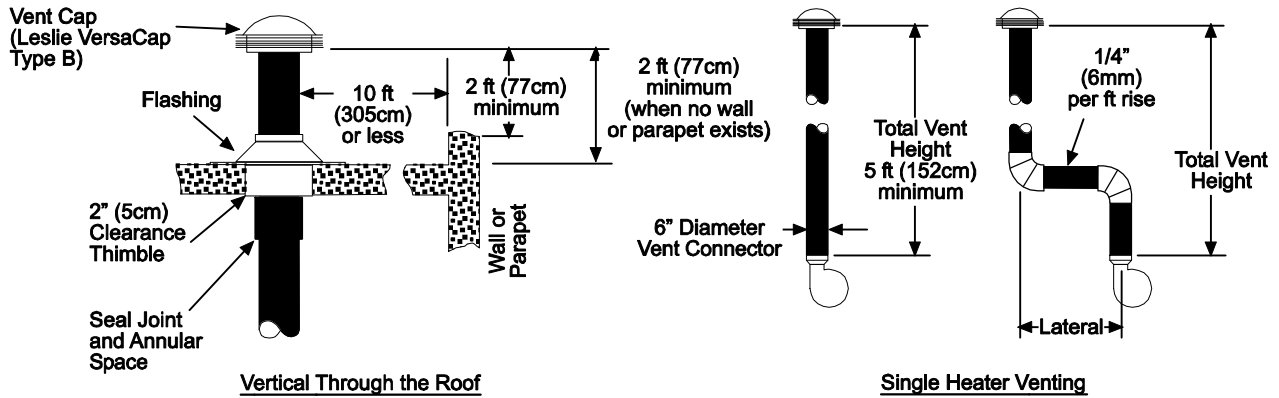

SINGLE HEATER VENTING (HORIZONTAL THROUGH SIDEWALL)

When venting the heater horizontally through a combustible outside sidewall, the same requirements listed previously for venting **Vertical Through The Roof** apply except as follows:

1. A vent passing through a combustible wall must pass through an approved clearance thimble (Air-Jet #4VT or Ameri-Vent #4EWT or other thimbles) that are listed by a nationally recognized testing agency. Double-wall Type B vent must be used for the portion of the vent system which passes through the combustible sidewall.
2. An approved vent cap (Breidert-Type L or equal) must be attached to the end of the vent pipe.
 - Minimum Equivalent Length = 5 ft. of pipe
 - Maximum Equivalent Length = 75 ft. of pipe

NOTE: To minimize problems associated with condensation in long horizontal runs, vent pipe can be insulated.

3. When venting through a sidewall, the horizontal vent pipe shall rise not less than 1/4 inch per foot from the start of the vent system to the vent terminal. All portions of the vent pipe shall be supported to prevent sagging. (6' spacing is recommended)
4. A minimum clearance of 6 inches must be maintained between the outside wall and vent cap.
5. The horizontal venting system shall not terminate:
 - Less than 4 ft. (1.2m) below, 4 ft. (1.2m) horizontally from or 1 ft. (30cm) above any door, operable window or gravity air inlet into any building. The bottom of the vent terminal shall be located at least 7 ft. (2.1m) above grade or above snow accumulation level as determined by local codes.
 - Less than 3 ft. (0.9m) from a combustion air inlet.
 - Less than 3 ft. (0.9m) from any other building opening or any gas service regulator.
 - Less than 7 ft. (2.1m) above public walkways.
 - Directly over areas where condensate or vapor could create a nuisance or hazard or be harmful to the operation of gas utility meters, regulators, relief valves, or other equipment. Building materials should be protected from flue gases and condensate.
 - Less than 12" (0.30m) when directly below a combustible overhang.
6. In regions of the country where prevailing winds are consistently higher than 40 mph, it may be necessary to terminate the vent system above the roof level.

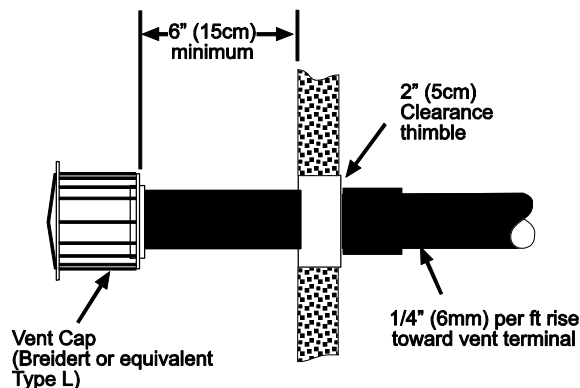

Horizontal Through Sidewall

MULTIPLE HEATER VENTING (CONNECTIONS INTO A COMMON VENT OR MANIFOLD)

Requirements for venting of multiple heaters are the same as described for **SINGLE HEATER VENTING** except as follows:

1. The common vent size and total vent height is normally determined by the number of heaters per common vent, length of horizontal connector runs, and connector rise. Connector lengths should be as short as possible and have a minimum 1/4 inch per foot rise. Without regard to connector rise and total vent height due to many possible venting configurations, the following should be observed:
 - Common vent pipe & vent connector diameter should be no less than that shown in the following Vent Sizing Table.
 - The connector length should be no more than 75% of the vertical portion of vent above the connector.
 - Where possible, use a Y-connector to the common vent.
2. Material for connectors should be constructed of galvanized sheet metal or other approved noncombustible corrosion resistant material as allowed by state or local codes. All common vent pipe should be double-wall, Type B vent.
3. Avoid unnecessary bends. Limit to two (2) 90° elbows.
4. The entire length of vent connector shall be readily accessible for inspection, cleaning and replacement.
5. Groups of heaters with a common vent must be controlled by a common thermostat.

Multiple Heater Vertical Venting Arrangement

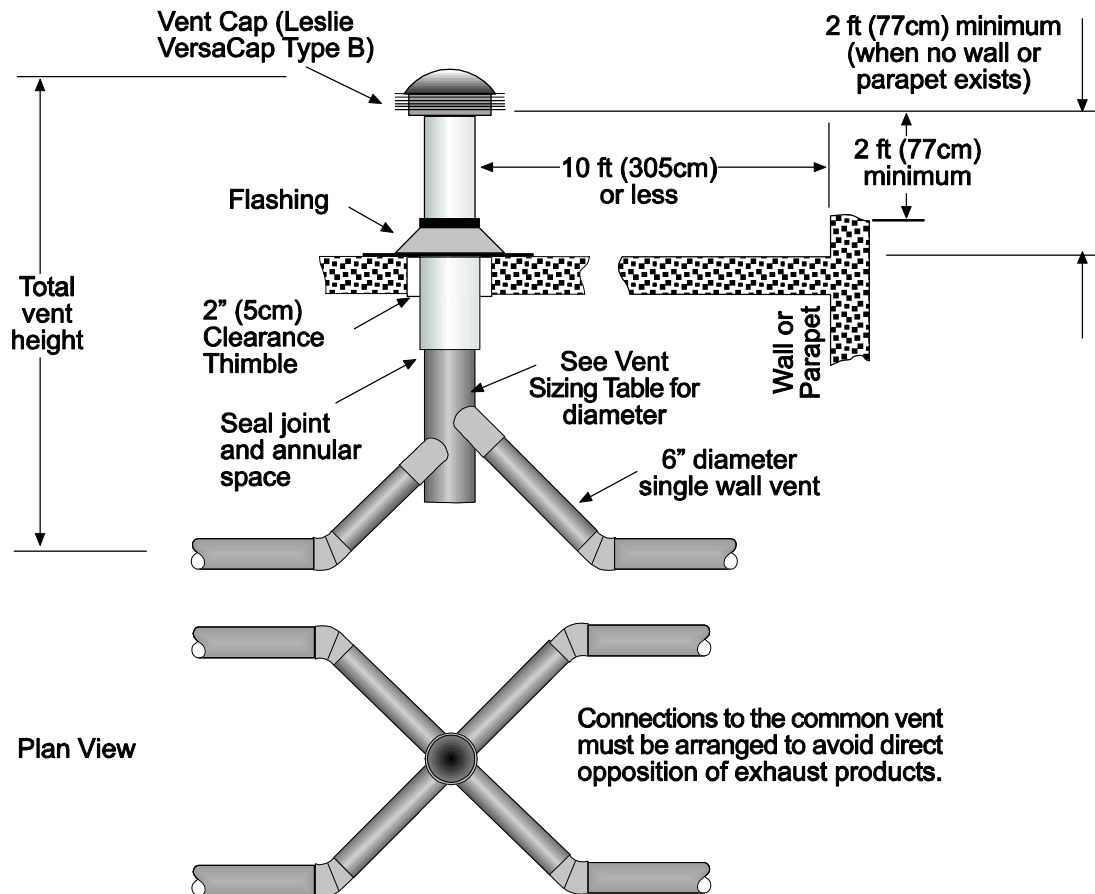

Multiple Heater Horizontal Venting Arrangement

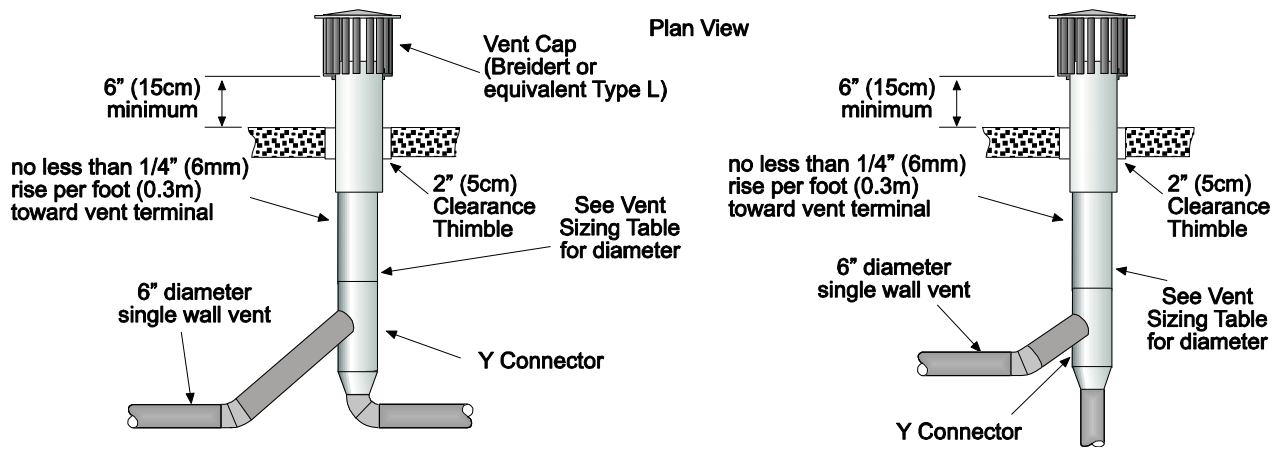

Multiple Heater Venting (Connections into a Manifold)

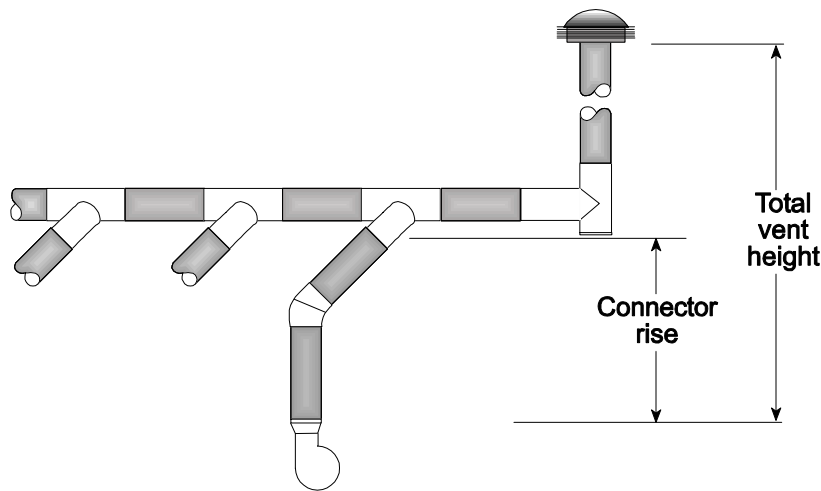

B. INDIRECT VENTING (UNVENTED HEATERS) — This heater requires ventilation in the building to dilute the products of combustion and provide fresh air for efficient combustion. Where unvented heaters are used, gravity or mechanical means shall be provided to supply and exhaust at least 4 CFM per 1,000 Btu/hr input of installed heaters. Exhaust vents must be located at the highest point above and in the vicinity of the heaters, and the inlet vents must be located below the level of the heaters. An exhaust hood must be used as described in Section 6. **NOTE:** Exhaust Hoods are supplied as Accessory items.

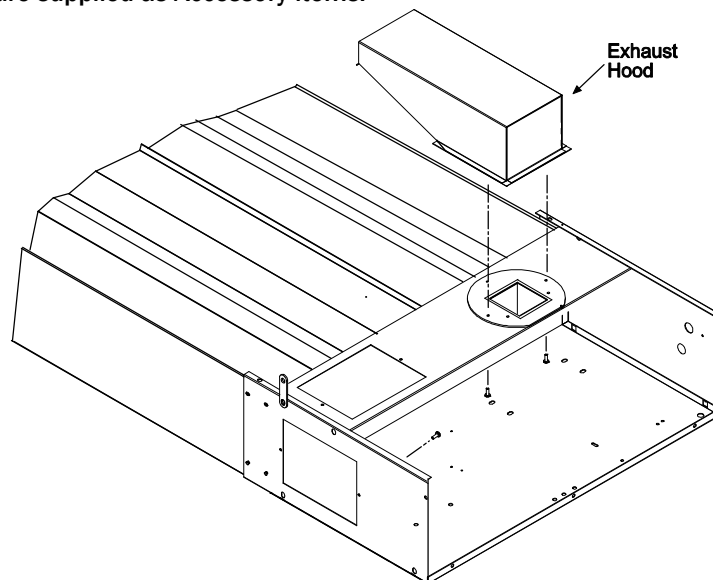

12) AIR FOR COMBUSTION

If indoor combustion air is to be supplied for a tightly enclosed area, one square inch of free area opening shall be provided below the heater for each 1,000 Btu/hr of heater input. Adequate clearances around the air inlet screen must be maintained at all times. In larger open areas of buildings, infiltration normally is adequate to provide air for combustion.

13) DIRECT OUTSIDE AIR FOR COMBUSTION

Outside combustion air should be supplied directly to the heater when the building is subject to negative pressure, or when contaminants or high humidity are present in the building air. These contaminants include paints, solvents, corrosive vapors or any other foreign particles that may cause damage to the heater or result in poor combustion.

Outside combustion air can be brought directly to the heater by a 6" diameter duct less than 50 ft. long or equivalent (see table in Section 11). This is attached to the 6" diameter starting collar. The starting collar is fitted to the top of the control box cabinet **after first removing and discarding the perforated cover and installing an adapter plate (Part #4278300)**. Alternately the combustion air can be brought from the side, after replacing the solid cover panel on the side with an adapter plate, and replacing the perforated cover panel on the top with the solid cover panel from the side. An approved vent cap must be placed directly on the end of the outside combustion air inlet pipe. The combustion air inlet should be not less than 3 ft. (0.9m), either vertically or horizontally, from the flue vent termination. The air intake terminal must be located not less than 1 ft. (30cm) above grade. It is good installation practice to supply combustion air from the same pressure zone as the vent outlet. Avoid bringing combustion air to the heater from an attic space. There is no guarantee that adequate combustion air will be supplied.

In colder climates, where necessary, insulate the outside combustion air duct. Avoid locating the outside combustion air duct directly above the control box. Provide a capped cleanout T as necessary. In high humidity applications, the control box should be sealed with silicone sealer.

In **multiple heater applications**, the combustion air intake may be ducted individually or common ducted in the same configuration as shown for venting in Section 11. For combustion air intake duct sizing, please refer to the **Vent Sizing Table** and use the diameter indicated, based on the number of heaters per duct.

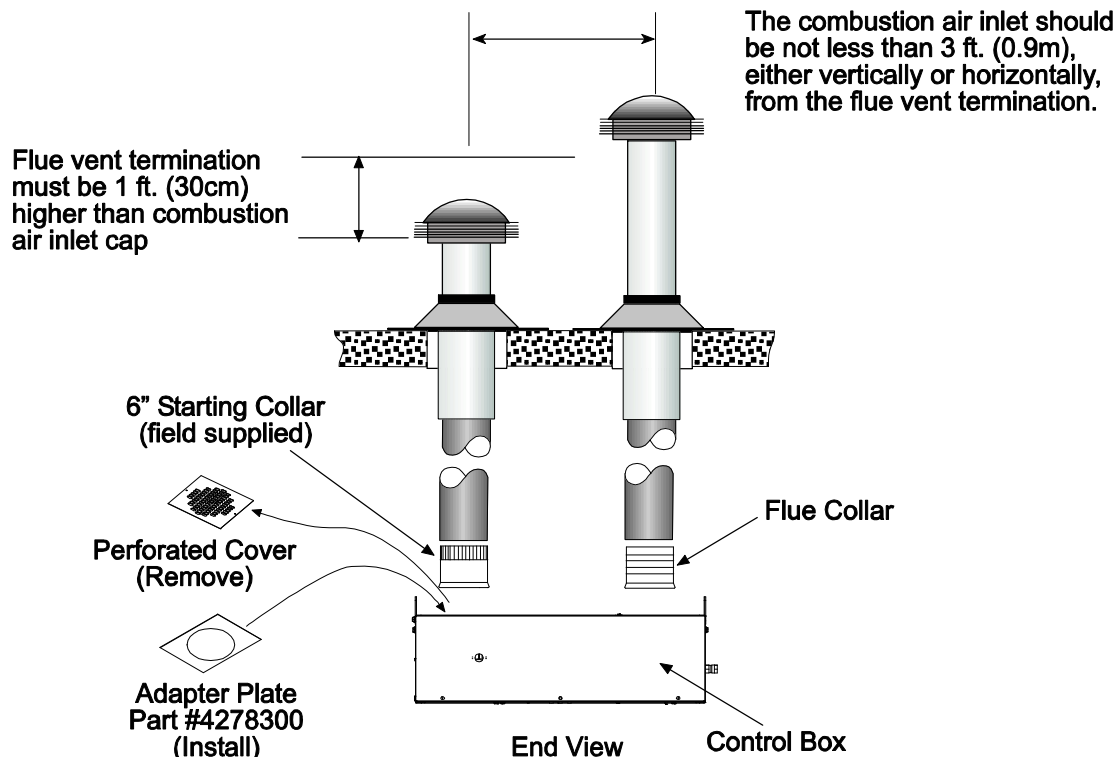

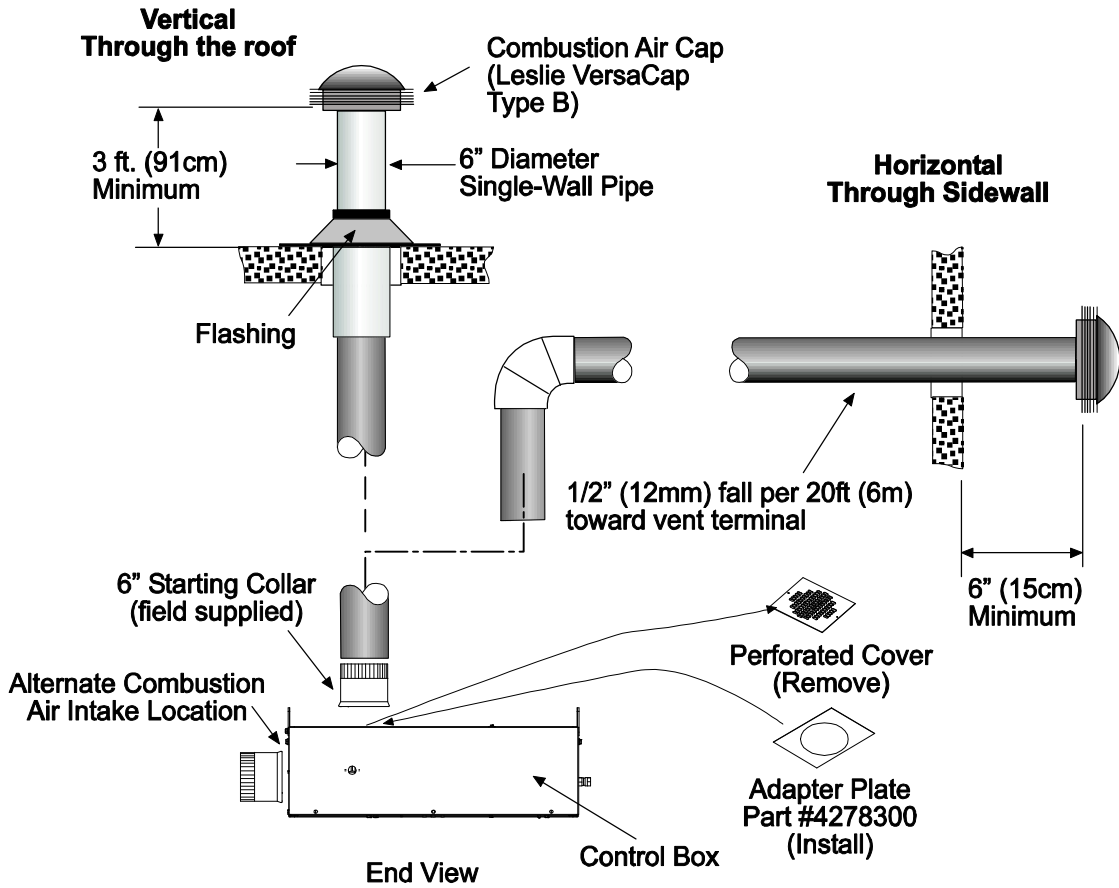

14) Sequence of Operation

The chart below shows the sequence of operation for the normal operating cycle.

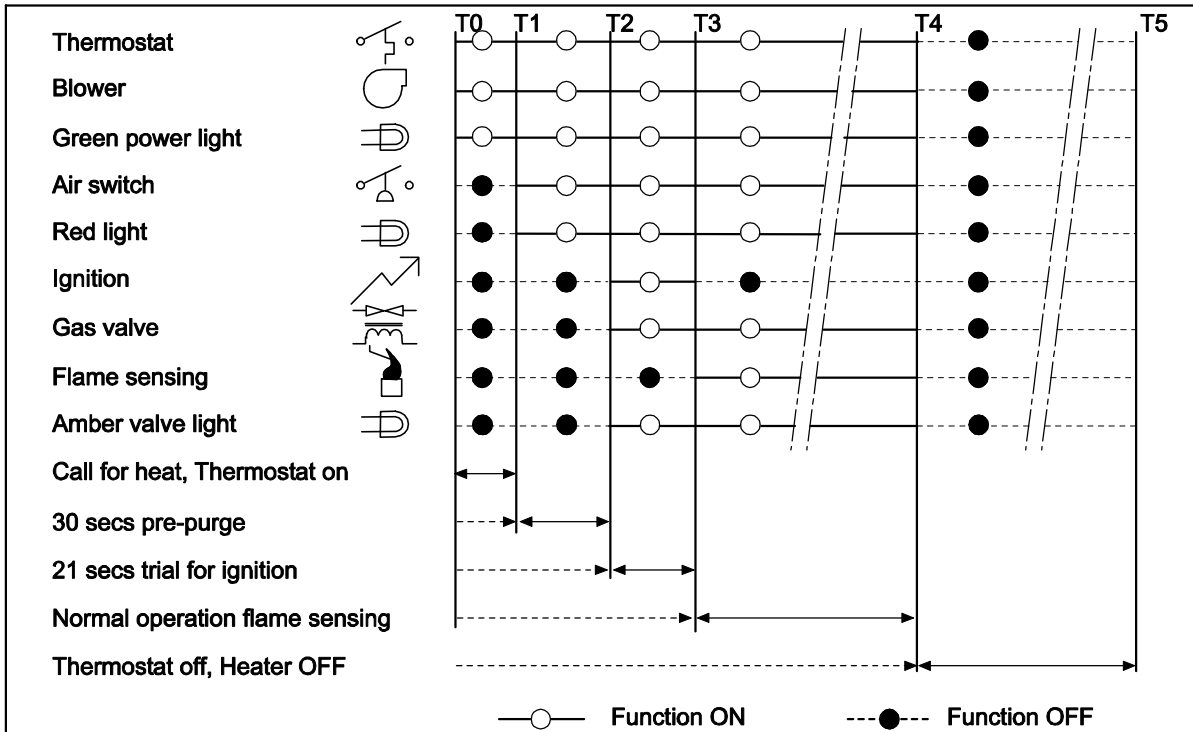

If the flame is not sensed during sequence T3 then the burner will automatically begin ignition sequence T2. If the flame is not re-established the heater will go to lockout.

15) LIMITED WARRANTY

LIMITED WARRANTY: Gas-Fired Products, Inc., the manufacturer, warrants to the original owner of any Space-Ray infrared gas heater that said heater will be free from defects in material or workmanship under normal use and service. The heater(s) shall be installed, used and maintained strictly in accordance with the manufacturer's instructions. The manufacturer's sole obligation under this warranty shall be limited to furnishing replacement parts, F.O.B. Charlotte, NC, for 12 months from the date of installation, or 18 months from the date of shipment by the manufacturer, whichever period shall expire first. Labor charges for removal of defective parts and the installation of the replacement parts are not included. This warranty applies only within the USA and Canada.

WARNING: Manufacturer's warranty shall not apply: (a) to damage to the heater when used in an atmosphere containing halogenated hydrocarbons or other corrosive chemicals. Some compounds in the air can be ingested into the equipment and can cause an accelerated rate of corrosion of some of the parts of the heating components. The use of such chemical compounds in or near the operating environment of the heater should be avoided where a longer heater life is desirable; (b) to any heater or components which have been repaired or replaced with other than factory parts, modified in any way, misused or damaged, or which have been used contrary to the manufacturer's written instructions. Replacement parts are available through Space-Ray representatives or their distributors.

LIMITATION OF WARRANTY: THERE ARE NO WARRANTIES, EXPRESS OR IMPLIED, WHICH EXTEND BEYOND THE DESCRIPTION ON THE FACE HEREOF. WITHOUT LIMITING THE FOREGOING, THE MANUFACTURER EXPRESSLY EXCLUDES ANY AND ALL IMPLIED WARRANTIES, INCLUDING BUT NOT LIMITED TO ANY IMPLIED WARRANTY OF FITNESS FOR A PARTICULAR PURPOSE AND ANY IMPLIED WARRANTY OF MERCHANTABILITY FOR ITS PRODUCTS.

If any provision of this warranty is found to be void, unenforceable or unconscionable, then the same is hereby severed and the remainder of this warranty is hereby saved and shall remain in force.

EXCLUSIVE REMEDY: The sole and exclusive remedy under this warranty is the replacement of the defective parts or heaters as hereinabove specified. THE MANUFACTURER DOES HEREBY EXPRESSLY EXCLUDE ANY AND ALL LIABILITY FOR INCIDENTAL AND CONSEQUENTIAL DAMAGES UNDER THIS OR ANY OTHER WARRANTY. Without intending to limit the aforesaid exclusion, THE MANUFACTURER DOES HEREBY EXCLUDE ANY LIABILITY UNDER THIS OR ANY OTHER WARRANTY FOR INJURIES AND COMMERCIAL LOSSES TO PROPERTY THAT RESULT FROM THE OPERATION, PROPER OR IMPROPER, OF ITS PRODUCTS.

ADDITIONAL WARRANTY ON HEAT EMITTING SURFACE AND BURNER: Manufacturer warrants to the original owner of any CSA design certified heater that, if installed, used and maintained strictly in accordance with the printed instructions received with the heater, the manufacturer will at any time during the below listed time periods, furnish at no cost to the original owner, replacement emitters or burners which have become inoperative by reason of any defect in our workmanship, materials or construction. The manufacturer's obligation under this warranty shall be limited to furnishing replacements under the following time periods from the date of installation:

| | <u>Emitter</u> | <u>Burner</u> |
|--------------|----------------|---------------|
| RSTP Series: | 5 Years | 10 Years |

The manufacturer will not be responsible for labor charges incurred for removal or installation of emitters. Any transportation charges involved in the return or repair are excluded.

ADDITIONAL TERMS: Manufacturer assumes no liability for delay in performing its obligations under the aforesaid warranty. Manufacturer assumes no liability for failure in performing its obligations thereunder if failure results directly or indirectly from any cause beyond its control, including but not limited to acts of God, acts of Government, floods, fires, shortages of materials, strikes and other labor difficulties or delays or failures of transportation facilities.

This is a Non-Residential product (excluding the CB Series which is certified for residential and non-residential use). Installation and service shall be by a Licensed Contractor and in accordance with National and Local Codes.

When presenting warranty claims, proof of date of purchase must be submitted.

No Representative is authorized to assume for the manufacturer any liability except as set forth above.

SPACE-RAY®

A Division of Gas-Fired Products, Inc.

Post Office Box 36485 (28236) • 305 Doggett Street (28203) • Charlotte, North Carolina
Phone (704) 372-3485 • Fax (704) 332-5843 • www.spaceray.com • email: info@spaceray.com